



# basic education

---

Department:  
Basic Education  
**REPUBLIC OF SOUTH AFRICA**

## **SENIOR CERTIFICATE EXAMINATIONS/ NATIONAL SENIOR CERTIFICATE EXAMINATIONS**

**ELECTRICAL TECHNOLOGY: POWER SYSTEMS**

**2022**

**MARKS: 200**

**TIME: 3 hours**

**This question paper consists of 18 pages and a 2-page formula sheet.**

## **INSTRUCTIONS AND INFORMATION**

1. This question paper consists of SEVEN questions.
2. Answer ALL the questions.
3. Sketches and diagrams must be large, neat and FULLY LABELLED.
4. Show ALL calculations and round off answers correctly to TWO decimal places.
5. Number the answers correctly according to the numbering system used in this question paper.
6. You may use a non-programmable calculator.
7. Calculations must include:
  - 7.1 Formulae and manipulations where needed
  - 7.2 Correct replacement of values
  - 7.3 Correct answers and relevant units where applicable
8. A formula sheet is attached at the end of this question paper.
9. Write neatly and legibly.

**QUESTION 1: MULTIPLE-CHOICE QUESTIONS**

Various options are provided as possible answers to the following questions. Choose the answer and write only the letter (A–D) next to the question numbers (1.1.1 to 1.1.15) in the ANSWER BOOK, e.g. 1.16 D.

- 1.1 The layer(s) of the skin that is/are affected by a third-degree burn would be ...
- A the outer layer.
  - B the second layer.
  - C all layers of the skin.
  - D None of the above-mentioned
- (1)
- 1.2 The power factor in an RLC series circuit will be lagging if  $V_L$  ...
- A is greater than  $V_C$ .
  - B is less than  $V_C$ .
  - C is equal to  $V_C$ .
  - D None of the above-mentioned
- (1)
- 1.3 A circuit has a resistance of  $R$  ohm, an inductance of  $L$  henry and a capacitance of  $C$  farad connected in series. The power factor of the circuit will be at unity (1) when ...
- A  $X_L$  is less than  $X_C$ .
  - B  $X_L$  is greater than  $X_C$ .
  - C  $X_L = X_C$ .
  - D  $R = 0$ .
- (1)
- 1.4 Which ONE of the following conditions exists in a resonant parallel RLC circuit?
- A The impedance is minimum.
  - B The impedance is maximum.
  - C The total current is maximum.
  - D The power factor is lagging.
- (1)
- 1.5 Name the type of transformer used immediately after generation with reference to generation and transmission of electricity:
- A Step-down transformer
  - B Step-up transformer
  - C Autotransformer
  - D Single-phase transformer
- (1)

- 1.6 After adding power factor correcting capacitors in parallel with a load, the power factor increased from 0,6 to 0,9. With the load unchanged, the current drawn from the supply will ...
- A increase.
  - B decrease.
  - C remain the same.
  - D double. (1)
- 1.7 Power factor is the ...
- A real power consumed by the load.
  - B power expended by a purely inductive or purely capacitive circuit.
  - C product of line voltage and line current.
  - D ratio of real power to apparent power. (1)
- 1.8 A cooling method used for a dry type transformer is ...
- A air forced.
  - B oil forced, air forced.
  - C oil forced, water forced.
  - D oil natural. (1)
- 1.9 The transfer of energy from the primary winding to the secondary winding in transformers happens through ...
- A self-induction.
  - B an electrical connection.
  - C mutual induction.
  - D an optical connection. (1)
- 1.10 The minimum value allowed for an insulation resistance test between windings is ...
- A 1 k $\Omega$ .
  - B 10 k $\Omega$ .
  - C 100 k $\Omega$ .
  - D 1 M $\Omega$ . (1)
- 1.11 The purpose of a no-volt relay is to ...
- A allow a motor to automatically start after a power failure is restored.
  - B increase the voltage of a three-phase motor.
  - C prevent a motor from automatically starting when a power failure is restored.
  - D monitor the amount of current drawn by a motor. (1)

- 1.12 The start button used in a motor control circuit is ...
- A normally open.
  - B open-relay contact.
  - C normally closed.
  - D closed-relay contact.
- (1)
- 1.13 ... is the machine language that is installed on a computer or written into the control program of a PLC.
- A Hardware
  - B Software
  - C Firmware
  - D Electronics
- (1)
- 1.14 Which part of the PLC scan cycle executes the programmed instructions?
- A Input scan
  - B Process scan
  - C Output scan
  - D Hardware scan
- (1)
- 1.15 A variable speed drive where the voltage applied to the motor is directly related to the frequency is called a ...
- A V/Hz drive.
  - B frequency drive.
  - C vector drive.
  - D All the above-mentioned
- (1)  
**[15]**

**QUESTION 2: OCCUPATIONAL HEALTH AND SAFETY**

- 2.1 Explain the term *machinery* with reference to the Occupational Health and Safety Act, 1993 (Act 85 of 1993). (2)
- 2.2 Explain the term *critical incident* with regard to emergencies. (2)
- 2.3 State TWO steps you should take when you discover a fire in an electrical workshop. (2)
- 2.4 State the importance of wearing a face mask in the workshop. (2)
- 2.5 Name TWO environmental considerations when working with chemicals during the printed circuit board manufacturing process. (2)
- [10]**

**QUESTION 3: RLC CIRCUITS**

- 3.1 Define *phasor diagram* with reference to RLC circuits connected across an alternating voltage supply. (2)
- 3.2 FIGURE 3.2 below shows a series RLC circuit which consists of a resistor with a resistance of  $10 \Omega$ , an inductor with an inductive reactance of  $14 \Omega$  and a capacitor with a capacitive reactance of  $8 \Omega$ , all connected across an alternating supply of  $100 \text{ Hz}$ .

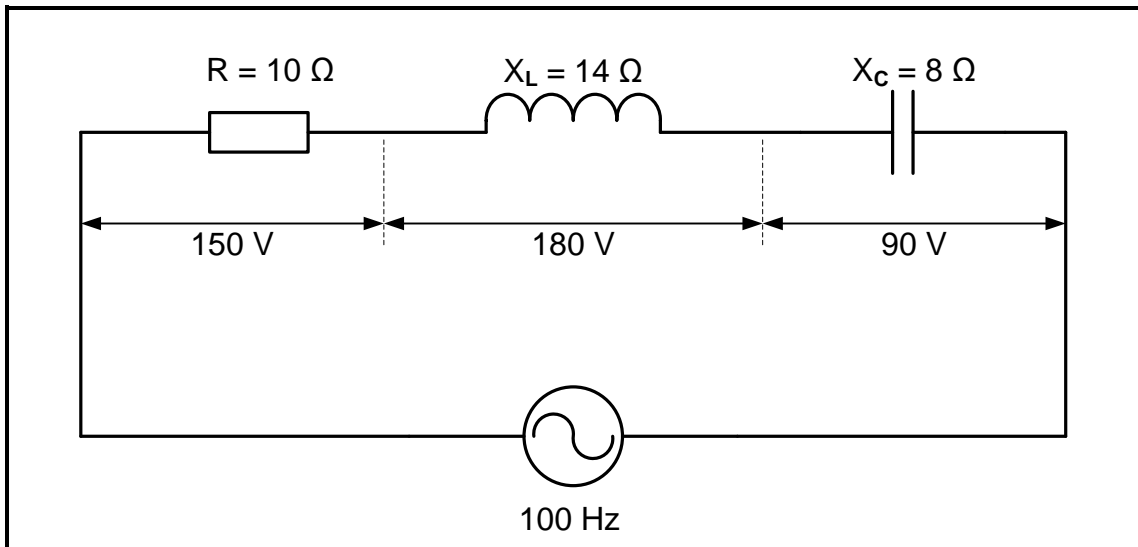
**FIGURE 3.2: SERIES RLC CIRCUIT**

Given:

$$\begin{aligned} R &= 10 \Omega \\ X_C &= 8 \Omega \\ X_L &= 14 \Omega \\ V_R &= 150 \text{ V} \\ V_L &= 180 \text{ V} \\ V_C &= 90 \text{ V} \\ f &= 100 \text{ Hz} \end{aligned}$$

- 3.2.1 Calculate the total supply voltage applied to the circuit. (3)
- 3.2.2 Discuss whether the power factor will be leading or lagging. (3)

3.3 Refer to FIGURE 3.3 below and answer the questions that follow.

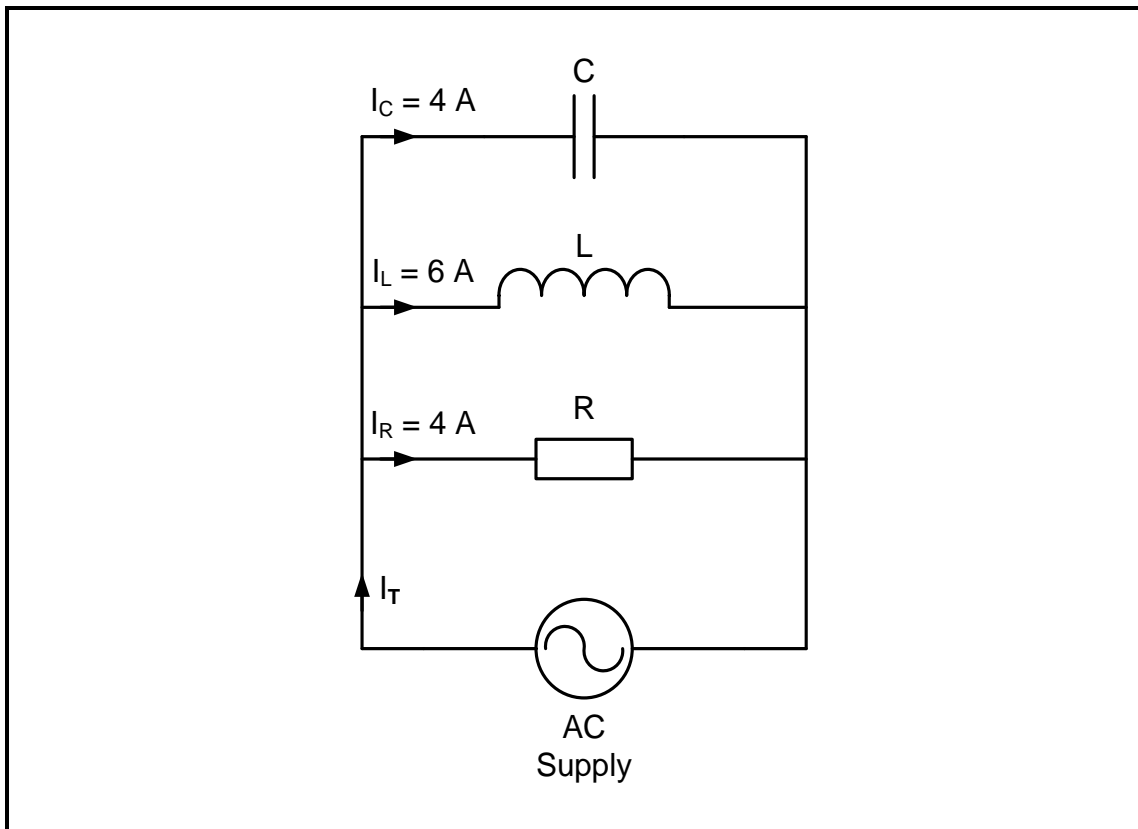

**FIGURE 3.3: PARALLEL RLC CIRCUIT**

Given:

$$I_C = 4\text{ A}$$

$$I_L = 6\text{ A}$$

$$I_R = 4\text{ A}$$

- 3.3.1 Calculate the total current. (3)
- 3.3.2 Calculate the phase angle. (3)
- 3.3.3 Draw the phasor diagram for FIGURE 3.3. (4)
- 3.3.4 Motivate with a reason if the circuit is predominately capacitive or inductive. (2)



3.4 Refer to FIGURE 3.4 below and answer the questions that follow.

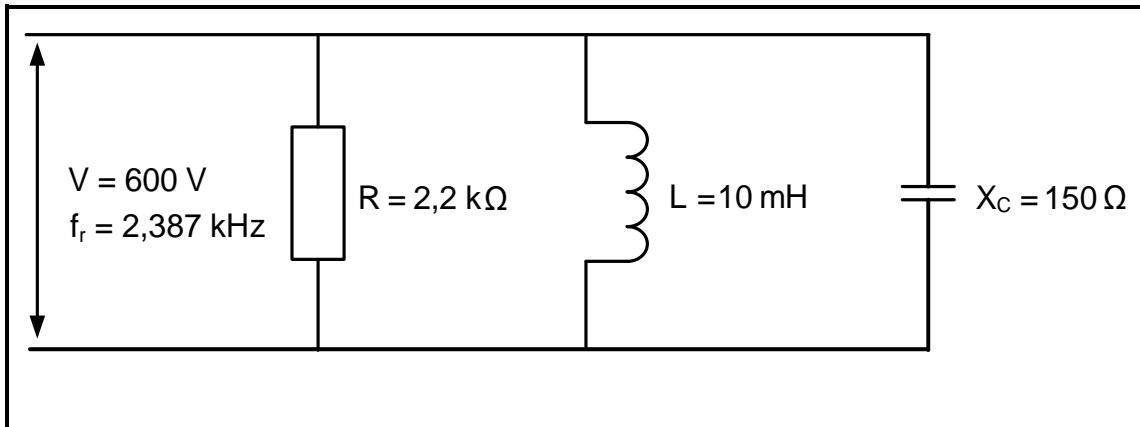

**FIGURE 3.4: RESONANT RLC CIRCUIT**

- 3.4.1 Calculate the quality factor of the circuit. (3)
- 3.4.2 Calculate the bandwidth. (3)
- 3.4.3 Calculate the value of the capacitor. (3)
- 3.4.4 Define the term *selectivity* with reference to resonant circuits. (2)

3.5 Refer to FIGURE 3.5 below and answer the questions that follow.

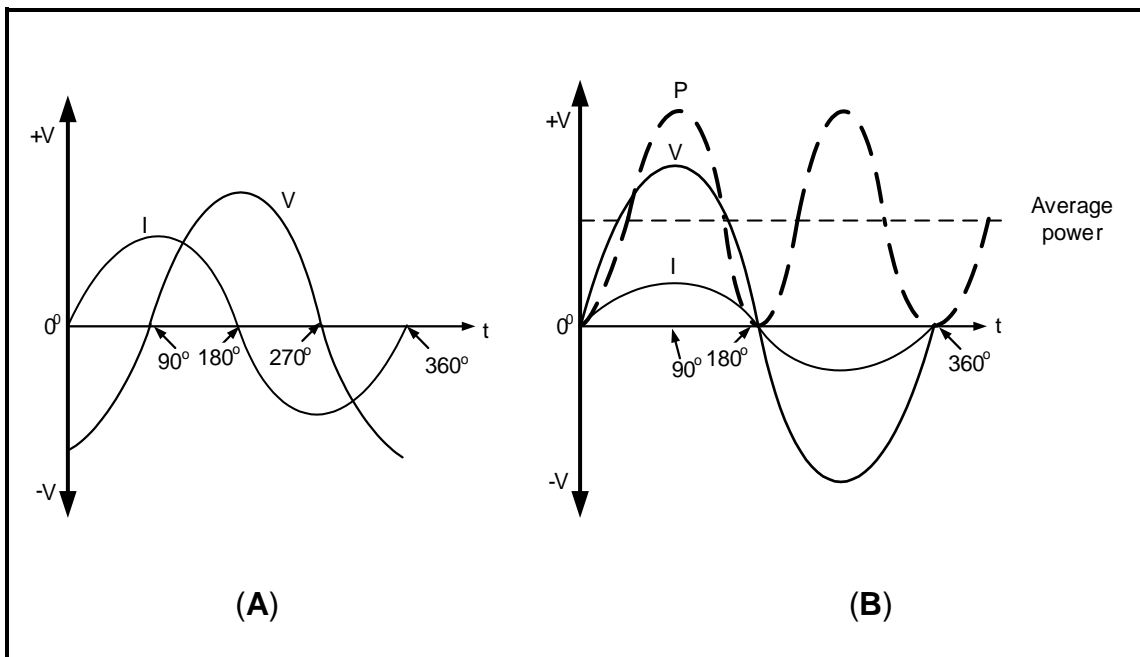

**FIGURE 3.5: CURRENT, VOLTAGE AND POWER WAVEFORMS**

- 3.5.1 State with a reason the type of component that produces the waveform in FIGURE 3.5 (A). (2)
- 3.5.2 Identify the component across which power is dissipated in FIGURE 3.5 (B). Motivate your answer. (2)

**[35]**

**QUESTION 4: THREE-PHASE AC GENERATION**

4.1 Refer to FIGURE 4.1 below and answer the questions that follow.

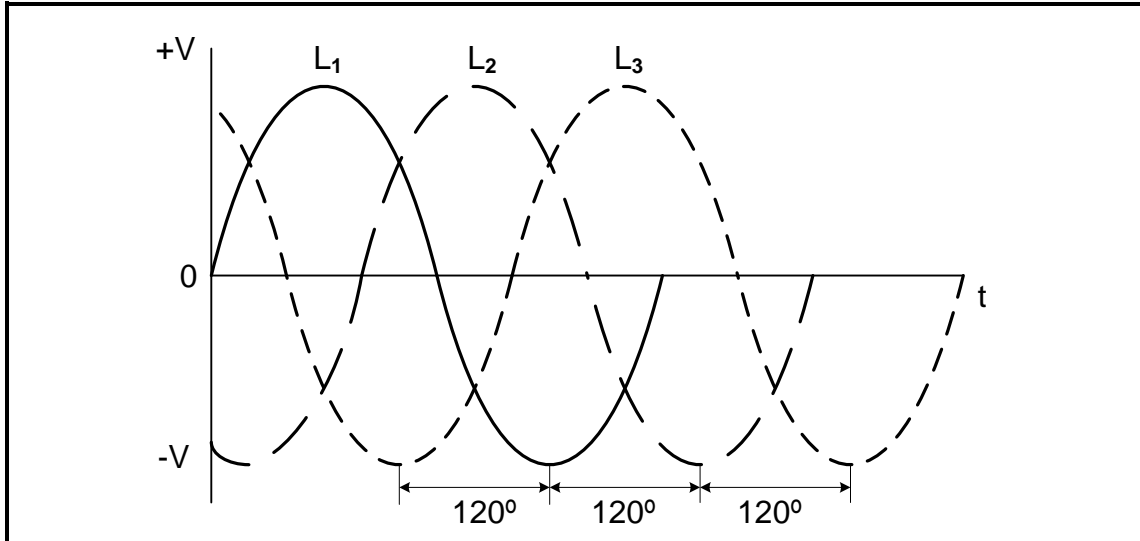

**FIGURE 4.1: THREE-PHASE WAVEFORM**

- 4.1.1 Write down the typical line voltage value of a three-phase supply for the end user. (1)
- 4.1.2 Write down the standard international colour code for **L<sub>1</sub>**, **L<sub>2</sub>** and **L<sub>3</sub>**. (3)
- 4.1.3 Draw a phasor diagram for the waveforms in FIGURE 4.1. (5)
- 4.2 Name the **THREE** network stages of the national power grid in the **CORRECT** order. (3)
- 4.3 State how the following is measured in a star-connected system:
  - 4.3.1 Line voltage (1)
  - 4.3.2 Phase voltage (1)
- 4.4 Explain *reactive power* in an AC system. (2)

4.5 A three-phase generator delivers power to a star-connected load. The phase voltage of the load is 230 V with a line current of 35 amperes. The phase angle is  $18^\circ$ .

Given:

$$\begin{aligned} V_{ph} &= 230 \text{ V} \\ I_L &= 35 \text{ A} \\ \theta &= 18^\circ \end{aligned}$$

Calculate the following:

- 4.5.1 The line voltage (3)
- 4.5.2 Apparent power (3)
- 4.5.3 Reactive power (3)
- 4.5.4 True power (3)

4.6 Refer to FIGURE 4.6 below and answer the questions that follow. The readings on the wattmeters are  $W_1 = 960 \text{ W}$  and  $W_2 = 870 \text{ W}$ .

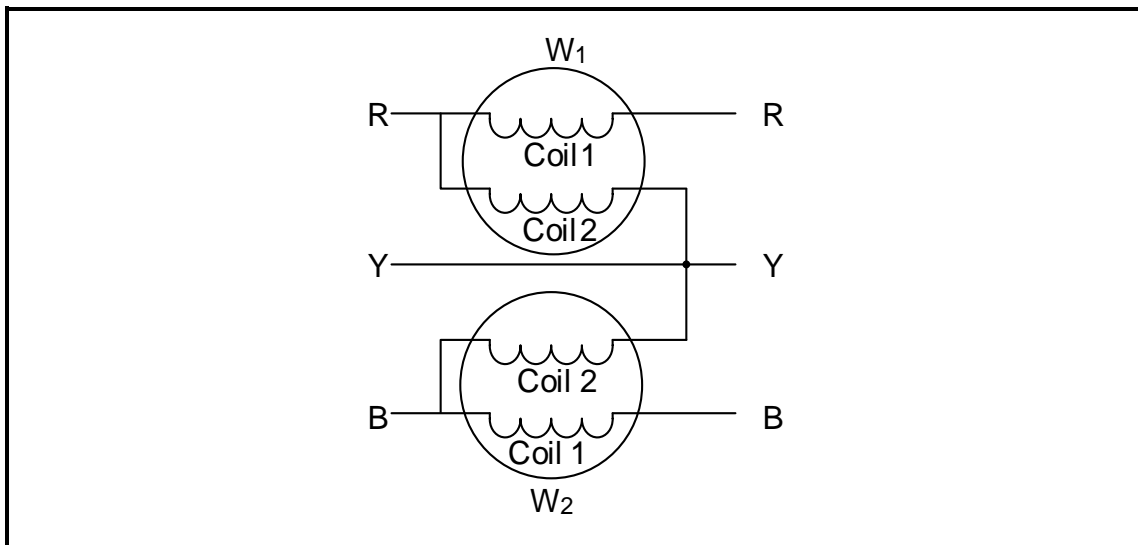

**FIGURE 4.6: TWO-WATTMETER METHOD**

Given:

$$\begin{aligned} W_1 &= 960 \text{ W} \\ W_2 &= 870 \text{ W} \end{aligned}$$

- 4.6.1 Identify the following coils:
  - (a) Coil 1 of  $W_1$  (1)
  - (b) Coil 2 of  $W_2$  (1)
- 4.6.2 Name TWO advantages of using this wattmeter method. (2)
- 4.6.3 Calculate the total power of the system. (3)

**[35]**

**QUESTION 5: THREE-PHASE TRANSFORMERS**

- 5.1 Name TWO types of transformer core constructions used in three-phase transformers. (2)
- 5.2 Explain why dielectric oil is used inside a transformer. (2)
- 5.3 State where the Buchholz relay is situated in an oil-cooled transformer. (2)
- 5.4 Draw a three-phase delta-star step-down transformer unit by using three identical single-phase transformers. (7)
- 5.5 A 10 kVA three-phase transformer has a copper loss of 300 W and a core loss of 50 W. The system operates at a power factor (p.f.) of 0,8.

Given:

copper loss = 300 W  
core loss = 50 W  
p.f. = 0,8  
S = 10 kVA

Calculate the following:

- 5.5.1 Output power (3)
- 5.5.2 Efficiency (3)

5.6 FIGURE 5.6 below shows a three-phase delta-star transformer.

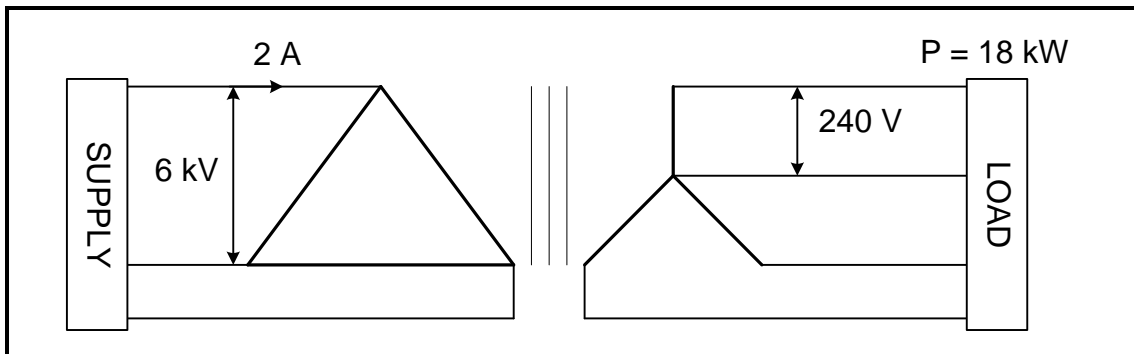

**FIGURE 5.6: THREE-PHASE TRANSFORMER**

Given:

$$\begin{aligned} V_{L1} &= 6 \text{ kV} \\ I_{L1} &= 2 \text{ A} \\ V_{ph2} &= 240 \text{ V} \\ P &= 18 \text{ kW} \end{aligned}$$

Calculate the following:

- 5.6.1 Rating of the transformer (apparent power) (3)
- 5.6.2 Power factor of the load (3)
- 5.6.3 Primary phase voltage (2)
- 5.6.4 Turns ratio (3)

**[30]**

**QUESTION 6: THREE-PHASE MOTORS AND STARTERS**

- 6.1 Name TWO continuity tests to be performed on a three-phase motor. (2)
- 6.2 Explain the term *cogging* with reference to induction motors. (2)
- 6.3 State TWO advantages of cage-type induction motors over wound rotor-type motors with slip rings and brushes. (2)
- 6.4 Name TWO applications of squirrel-cage induction motors where constant speed and torque is essential. (2)
- 6.5 Label points **A**, **B** and **C** on the characteristic curve in FIGURE 6.5 below. (3)

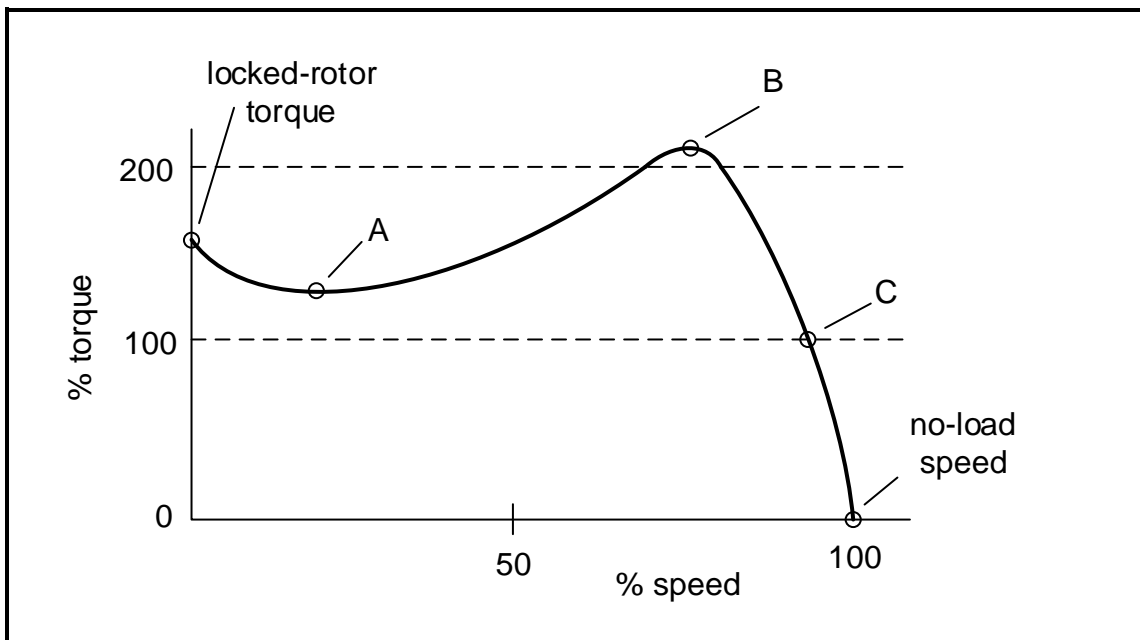

**FIGURE 6.5: SPEED VS TORQUE CHARACTERISTIC CURVE**

- 6.6 Differentiate between *synchronous speed* and *rotor speed*. (2)

- 6.7 The rotor of a three-phase induction motor with 3 pole pairs per phase rotates at 950 r/min when connected to a 380 V/50 Hz supply.

Given:

$$\begin{aligned}V_L &= 380 \text{ V} \\f &= 50 \text{ Hz} \\n_r &= 950 \text{ r/min} \\p &= 3\end{aligned}$$

Calculate the following:

- 6.7.1 Synchronous speed of the motor (3)
- 6.7.2 Percentage slip (3)
- 6.8 The input power to a three-phase motor is 5 kW. The losses are determined as 600 W.
- 6.8.1 Name TWO types of losses other than copper losses that influence the efficiency of an induction motor. (2)
- 6.8.2 Calculate the efficiency of the motor. (3)
- 6.8.3 Calculate the output power of the motor. (3)

6.9 The circuit in FIGURE 6.9 below is used to control TWO three-phase motors. Answer the questions that follow.

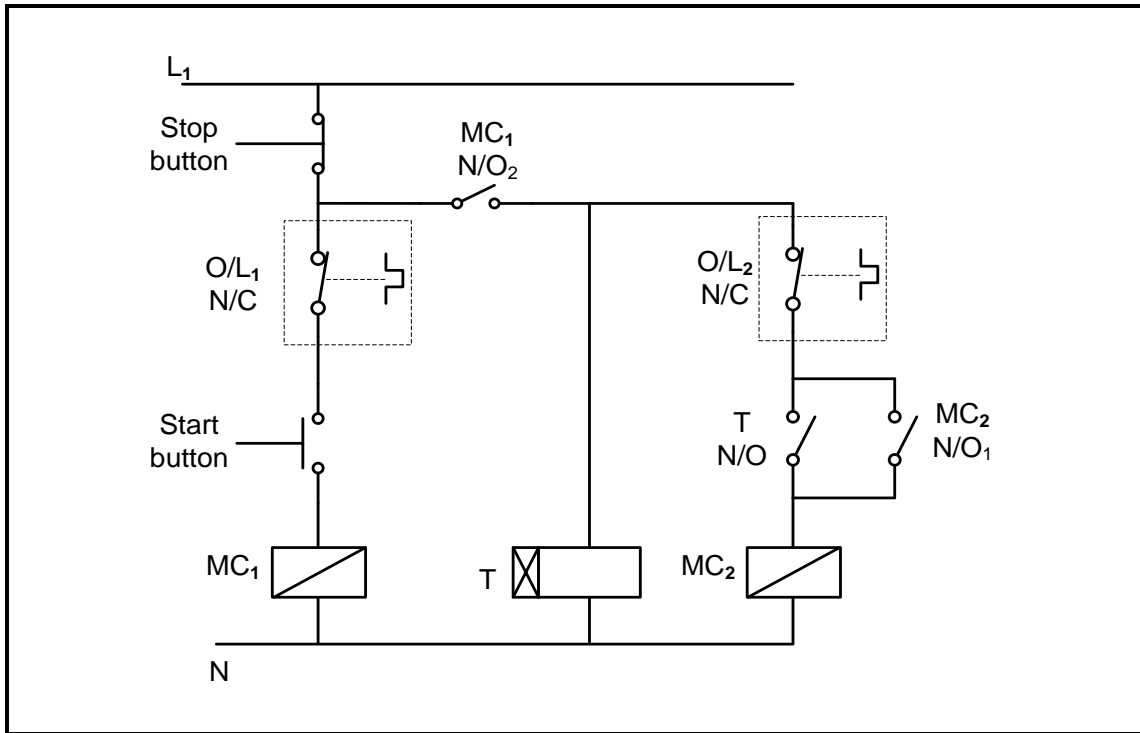

**FIGURE 6.9: AUTOMATIC SEQUENCE STARTER CONTROL CIRCUIT**

- 6.9.1 Identify component T. (1)
- 6.9.2 Explain the purpose of having TWO overload units in the circuit. (2)
- 6.9.3 Identify the error in the circuit. (1)
- 6.9.4 Describe how this error affects the operation of the circuit. (4)

**[35]**



**QUESTION 7: PROGRAMMABLE LOGIC CONTROLLERS (PLCs)**

- 7.1 Explain the function of the central processing unit (CPU) with reference to the hardware of a PLC. (3)
- 7.2 Name ONE advantage of soft-wired systems. (1)
- 7.3 Answer the following questions with reference to timers in PLC programming.
  - 7.3.1 State the purpose of a timer function. (2)
  - 7.3.2 Describe the difference between an *ON-delay timer* and an *OFF-delay timer*. (4)
- 7.4 Answer the following questions with reference to sensors as input devices of a PLC.
  - 7.4.1 Name TWO types of sensors other than a light sensor. (2)
  - 7.4.2 State TWO applications of a light sensor. (2)
- 7.5 FIGURE 7.5 below shows the control circuit of a direct-on-line (DOL) starter. Design a PLC ladder logic program that will execute the same function. (6)

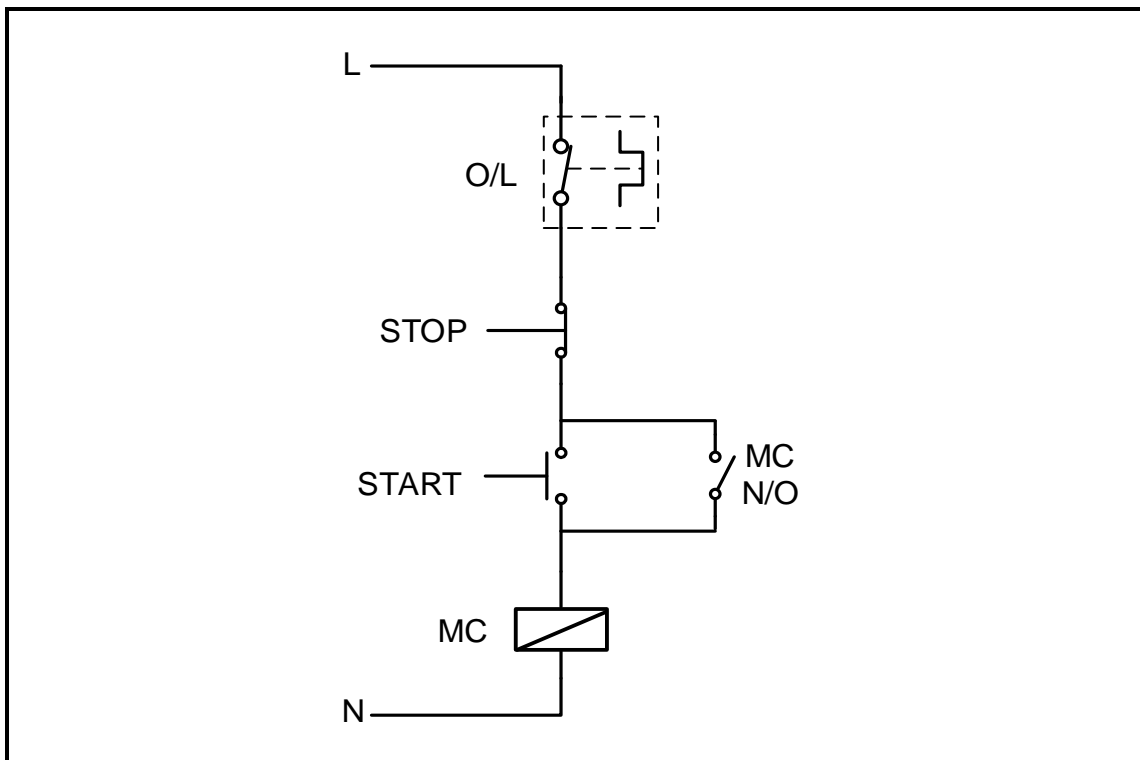

**FIGURE 7.5: CONTROL CIRCUIT OF A DIRECT-ON-LINE STARTER**

(6)

- 7.6 Answer the following questions with reference to regenerative braking.
- 7.6.1 Describe *regenerative energy*. (3)
- 7.6.2 List THREE applications where regenerative braking is used. (3)
- 7.7 Answer the following questions with reference to variable speed drives (VSDs).
- 7.7.1 Name TWO main parts of the VSD, other than the inverter. (2)
- 7.7.2 State TWO advantages of using VSDs with pumps, fans and other equipment. (2)
- 7.8 FIGURE 7.8 below shows the inverter stage of a VSD using IGBT transistors as semiconductor switches to drive a three-phase delta-connected motor. Answer the questions that follow.

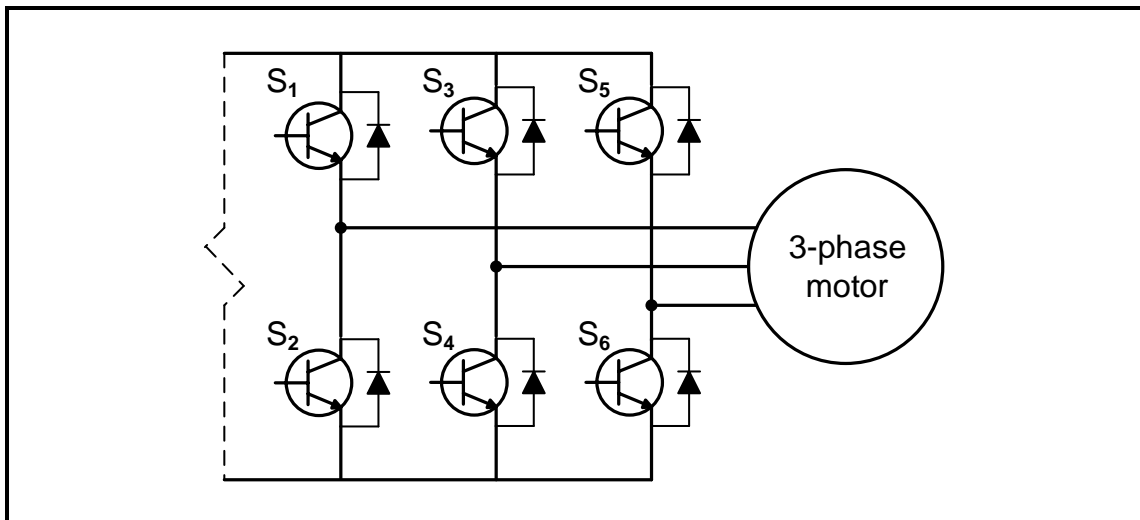

**FIGURE 7.8: INVERTER STAGE OF A VSD**

- 7.8.1 Identify the switches used to power each phase of the motor. (3)
- 7.8.2 Explain how the frequency to the motor is controlled. (2)
- 7.8.3 Explain how the DC supplied to the inverter stage is changed into AC for phase 1. (5)

**[40]**

**TOTAL: 200**

**FORMULA SHEET**

<b>RLC CIRCUITS</b>	<b>THREE-PHASE AC GENERATION</b>
$P = V \times I \times \cos \theta$ $X_L = 2\pi fL$ $X_C = \frac{1}{2\pi fC}$ $f_r = \frac{1}{2\pi\sqrt{LC}}$ <b>OR</b> $f_r = \frac{f_1 + f_2}{2}$ $BW = \frac{f_r}{Q}$ <b>OR</b> $BW = f_2 - f_1$ <b>SERIES</b> $V_R = IR$ $V_L = IX_L$ $V_C = IX_C$ $I_T = \frac{V_T}{Z}$ <b>OR</b> $I_T = I_R = I_C = I_L$ $Z = \sqrt{R^2 + (X_L - X_C)^2}$ $V_T = \sqrt{V_R^2 + (V_L - V_C)^2}$ <b>OR</b> $V_T = IZ$ $\cos \theta = \frac{R}{Z}$ <b>OR</b> $\cos \theta = \frac{V_R}{V_T}$ $Q = \frac{X_L}{R} = \frac{X_C}{R} = \frac{V_L}{V_T} = \frac{V_C}{V_T} = \frac{1}{R} \sqrt{\frac{L}{C}}$ <b>PARALLEL</b> $V_T = V_R = V_C = V_L$ $I_R = \frac{V_T}{R}$ $I_C = \frac{V_T}{X_C}$ $I_L = \frac{V_T}{X_L}$ $I_T = \sqrt{I_R^2 + (I_L - I_C)^2}$ $Z = \frac{V_T}{I_T}$ $\cos \theta = \frac{I_R}{I_T}$ $Q = \frac{R}{X_L} = \frac{R}{X_C}$	<b>STAR</b> $V_L = \sqrt{3} V_{ph}$ $V_{ph} = I_{ph} \times Z_{ph}$ $I_L = I_{ph}$ <b>DELTA</b> $V_L = V_{ph}$ $V_{ph} = I_{ph} \times Z_{ph}$ $I_L = \sqrt{3} I_{ph}$ <b>POWER</b> $S(P_{app}) = \sqrt{3} \times V_L \times I_L$ $Q(P_r) = \sqrt{3} \times V_L \times I_L \times \sin \theta$ $P = \sqrt{3} \times V_L \times I_L \times \cos \theta$ $\cos \theta = \frac{P}{S}$ <b>EFFICIENCY</b> $\eta = \frac{P_{out}}{P_{in}} \times 100$  <b>TWO-WATTMETER METHOD</b> $P_T = P_1 + P_2$ $\tan \theta = \sqrt{3} \left( \frac{P_1 - P_2}{P_1 + P_2} \right)$  <b>THREE-WATTMETER METHOD</b> $P_T = P_1 + P_2 + P_3$

THREE-PHASE TRANSFORMERS	THREE-PHASE MOTORS AND STARTERS
<p><b>STAR</b></p> $V_L = \sqrt{3} V_{ph}$ $I_L = I_{ph}$ <p><b>Delta</b></p> $V_L = V_{ph}$ $I_L = \sqrt{3} I_{ph}$ <p><b>POWER</b></p> $S(P_{app}) = \sqrt{3} \times V_L \times I_L$ $Q(P_r) = \sqrt{3} \times V_L \times I_L \times \sin \theta$ $P = \sqrt{3} \times V_L \times I_L \times \cos \theta$ $\cos \theta = \frac{P}{S}$ $\frac{V_{ph(1)}}{V_{ph(2)}} = \frac{N_1}{N_2} = \frac{I_{ph(2)}}{I_{ph(1)}}$ <p>Turns ratio: <math>TR = \frac{N_1}{N_2}</math></p> $\eta = \frac{P_{out}}{P_{out} + \text{losses}} \times 100$	<p><b>STAR</b></p> $V_L = \sqrt{3} V_{ph}$ $I_L = I_{ph}$ <p><b>DELTA</b></p> $V_L = V_{ph}$ $I_L = \sqrt{3} I_{ph}$ <p><b>POWER</b></p> $S(P_{app}) = \sqrt{3} \times V_L \times I_L$ $Q(P_r) = \sqrt{3} \times V_L \times I_L \times \sin \theta$ $P = \sqrt{3} \times V_L \times I_L \times \cos \theta$ $P = \sqrt{3} \times V_L \times I_L \times \cos \theta \times \eta$ $\cos \theta = \frac{P}{S}$ <p><b>EFFICIENCY</b></p> $\eta = \frac{P_{in} - \text{losses}}{P_{in}} \times 100$ $\eta = \frac{P_{out}}{P_{in}} \times 100$ $n_s = \frac{60 \times f}{p}$ <p>Per Unit Slip = <math>\frac{n_s - n_r}{n_s}</math></p> $\% \text{ Slip} = \frac{n_s - n_r}{n_s} \times 100$ $\text{Slip} = n_s - n_r$