



basic education

Department:
Basic Education
REPUBLIC OF SOUTH AFRICA

**NATIONAL
SENIOR CERTIFICATE**

GRADE 12

HOSPITALITY STUDIES

FEBRUARY/MARCH 2013

MARKS: 200

TIME: 3 hours

This question paper consists of 17 pages and 1 answer sheet.

INSTRUCTIONS AND INFORMATION

1. This question paper consists of FOUR sections.

SECTION A: Short questions	(40)
SECTION B: Hospitality concepts and health and safety	(40)
SECTION C: Food preparation	(80)
SECTION D: Food and beverage serving	(40)
2. Answer ALL the questions.
3. Number the answers correctly according to the numbering system used in this question paper.
4. Answer SECTION A on the attached ANSWER SHEET. Write the CENTRE NUMBER and your EXAMINATION NUMBER at the top of the ANSWER SHEETS, detach them and put them IN THE FRONT of the ANSWER BOOK.
5. Answer SECTIONS B, C and D in the ANSWER BOOK.
6. Write neatly and legibly.

SECTION A**QUESTION 1****1.1 MULTIPLE-CHOICE QUESTIONS**

Various options are provided as possible answers to the following questions. Choose the answer and make a cross (X) in the block (A–D) next to the question number (1.1.1–1.1.10) on the attached ANSWER SHEET.

EXAMPLE:

1.1.11 A good source of vitamin C is ...

- A milk.
- B oranges.
- C meat.
- D bread.

ANSWER:

A	<input checked="" type="checkbox"/>	B	C	D
---	-------------------------------------	---	---	---

1.1.1 The phrase 'beat any price' indicates that a company...

- A raises brand awareness.
- B raises consumer prices.
- C undermines new competitors.
- D undermines company policies.

(1)

1.1.2 A marketing plan should include a description of ...

- A unique features of your buying.
- B the marketing mix.
- C your administration records.
- D income and expenditure.

(1)

1.1.3 The number of items that must be sold before the fixed costs are covered is known as the ...

- A consumer price index indicator.
- B business description.
- C profit and loss.
- D break-even analysis.

(1)

1.1.4 Effective teamwork means ...

- A working alone to complete a task.
- B working towards the same objectives.
- C co-operating with one another only during crisis situations.
- D delegating you tasks to other team members.

(1)

- 1.1.5 Food items were left uncovered in a hot stuffy kitchen for 48 hours. Which ONE of the following food items is most likely to be spoiled by bacteria?
- A Cheese
 - B Rice
 - C Fruit
 - D Poultry
- (1)
- 1.1.6 A Hospitality Studies learner burnt his arm while he was removing a baking tray from the oven. The burn caused is classified as a ...
- A scald.
 - B dry burn.
 - C electrical burn.
 - D chemical burn.
- (1)
- 1.1.7 The setting of a gelatine mixture is prevented by the addition of pineapple, due to the presence of ...
- A bromelin.
 - B ficin.
 - C papain.
 - D lysine.
- (1)
- 1.1.8 A thin slice of meat (3–5 mm thick) cut from the thick flank is known as ... steak.
- A club
 - B minute
 - C porterhouse
 - D rump
- (1)
- 1.1.9 Liquor may NOT be served to persons under the age of ...
- A 16.
 - B 18.
 - C 21.
 - D 25.
- (1)
- 1.1.10 Food that is brought to the table on flat serving plates and offered to guests from the left is called ... service.
- A American
 - B Russian
 - C gueridon
 - D silver
- (1)

1.2 MATCHING ITEMS

Choose a description from COLUMN B that matches a term in COLUMN A. Write only the letter (A–G) next to the question number (1.2.1–1.2.5) on the attached ANSWER SHEET.

COLUMN A TERMS	COLUMN B DESCRIPTIONS
1.2.1 Christians	A meat and all food produced must have the halaal sign
1.2.2 Muslims	B mopani worms are considered a delicacy
1.2.3 Jews	C beef is forbidden as cows are considered to be sacred
1.2.4 Africans	D boiled tripe and pap is one of the traditional dishes on the menu
1.2.5 Hindus	E a group that will not consume meat on Good Friday
	F a group that will consume food that is only kosher
	G dairy and dairy products are forbidden

(5 x 1)

(5)

1.3 FILL IN THE MISSING WORD(S)

Complete the following sentences by filling in the missing word(s). Write only the word(s) next to the question number (1.3.1–1.3.10) on the attached ANSWER SHEET.

- 1.3.1 Gastro-enteritis causes loss of water from the body which leads to ...
- 1.3.2 When an individual faints, he/she must be placed in the ... position with knees bent.
- 1.3.3 ... rate is used to determine if the hotel is fully booked.
- 1.3.4 A list of items found in a cupboard or stock room is known as a/an ...
- 1.3.5 Salaries are referred to as ... costs.
- 1.3.6 FIFO is the abbreviation for ...
- 1.3.7 An ingredient used in pastry making to soften the gluten is ...
- 1.3.8 The ... in choux pastry is responsible for the production of steam during baking.
- 1.3.9 ... are deep-fried choux pastry, dusted with confectioner's sugar and served as a dessert.
- 1.3.10 A ... is a set of rules followed by employees in the workplace. (10)

1.4 SEQUENCE: RECEIVING GUESTS

Rearrange the steps of service below in the correct order. Write only the correct letters (A–E) next to the question number (1.4) on the ANSWER SHEET.

- A Once the food order is taken a waitron needs to correct the setting according to the requirements of the guests.
- B Seat guests and present the drinks menu.
- C Present the food menu and serve drinks.
- D Greet and seat guests.
- E Take food orders according to guests requirements. (5)

1.5 ONE-WORD ITEMS

Give one word/term for each of the following descriptions. Write only the word/ term next to the question number (1.5.1–1.5.10) on the ANSWER SHEET.

- 1.5.1 The attitude that encourages one to work quickly, efficiently, neatly and safely in a team
- 1.5.2 A friendly get-together where light snacks are served
- 1.5.3 The collective name for tablecloths, serviettes, overlays and service cloths
- 1.5.4 A collective name for non-consumable items such as a stove or refrigerator
- 1.5.5 A small upright soufflé dish used to cook individual portions of a variety of foods
- 1.5.6 The term given to items that is used daily during the food preparation process
- 1.5.7 A cost that is calculated on a monthly basis other than labour costs and food costs
- 1.5.8 The name given to a formal dinner held in celebration of a special event
- 1.5.9 The term on a wine label that indicates the year in which the grapes have been harvested
- 1.5.10 The food that is grown in the area that you live in (10)

TOTAL SECTION A: 40

SECTION B: HOSPITALITY CONCEPTS AND HEALTH AND SAFETY**QUESTION 2**

2.1 Study the extract below and answer the questions that follow.

A CRY FOR HELP

An area next to Binfield, on the way to Hogsback, was identified as a tourist destination some years ago. Community members were moved and houses were destroyed. The municipality was to develop the area. A dam and a restaurant were built. The municipality had a business plan for the Binfield restaurant which included a cover page, business address and the products they intended to offer. Ten years have passed, the dam is quiet and no tourists are attracted to the area as promised.

- 2.1.1 Suggest TWO forms of advertising that could be used by the community members to attract tourists. (2)
- 2.1.2 Outline FOUR effective ways that can be used when designing the marketing tool to promote the area above. (4)
- 2.1.3 Evaluate the Binfield business plan which was compiled by the municipality. (8)
- 2.1.4 Explain THREE ways in which the area above may contribute positively to the local economy. (3)
- 2.1.5 Name THREE entrepreneurship opportunities that may arise from Binfield village. (3)

2.2 Study the picture below and answer the questions that follow.

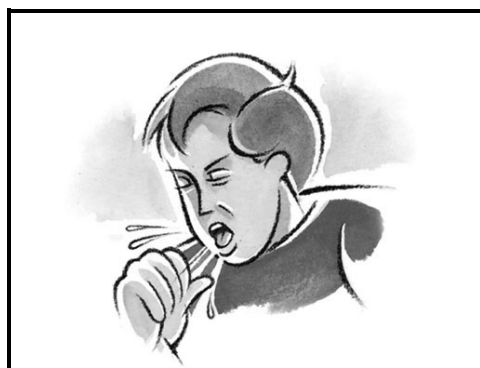

- 2.2.1 Predict what will happen if the above occurs in the kitchen. (2)
- 2.2.2 Recommend the treatment that can be given for the disease if the above person coughs continuously and is tired all the time. (2)
- 2.2.3 Explain how the disease in QUESTION 2.2.2 above can be avoided. (2)

- 2.3 Mrs Moodley conducted a practical Hospitality Studies lesson with Grade 12 learners. One learner fell, sprained an ankle and knocked her head against the table which caused her to bleed.
- 2.3.1 Explain how you will treat the sprained ankle. (4)
- 2.3.2 Explain how you could minimize the risk of HIV/Aids when helping the learner. (1)
- 2.3.3 Identify THREE essential items that should be kept in the first-aid kit which will be used to treat the injuries above. (3)
- 2.4 Employees should value proper work ethics and appropriate social behaviour.
Explain how you will achieve this in a work environment. (3)
- 2.5 Professional service comes with a smile.
Discuss this statement. (3)
- TOTAL SECTION B: 40**

SECTION C: FOOD PREPARATION**QUESTION 3**

3.1 In 2012 the your school celebrated its 50 years of existence. Best Food catering company has been hired to serve cocktail snacks. As a Hospitality Studies learner you are a member of the organising team.

- 3.1.1 Explain how computers can assist the above company when they prepare cocktail snacks for the function above. (4)
- 3.1.2 Give reasons for the recording of non-consumable stock on the computer by the Best Food catering company. (3)
- 3.1.3 Suggest TWO sweet snacks that should be included for individuals who are diabetic. (2)
- 3.1.4 Name THREE typically South African savoury dishes that can be served at the function above. (3)

3.2 Study the food items below and answer the questions that follow.

STARTER	MAIN COURSE	PRICE OF MAIN COURSE
Mint pea soup	Rolled sole with leeks	R25,50
Cheese vegetable chowder	Boiled egg chutney	R13,75
Devilleed eggs	Stuffed baby marrow slices	R11,20
Herbed cream roulade	Vegetable lasagne	R31,80
Ham and lentil soup	Mushroom soufflé	R17,75

- 3.2.1 Identify ONE starter and ONE main course from the list above that would be suitable for each of the following:
(Each dish may only be used ONCE.)
- A Vegan (2)
- B Lacto vegetarian (2)
- C Ovo-lacto vegetarian (2)
- D Ovo vegetarian (2)
- 3.2.2 The owner wants to ensure that he makes 50% profit. Calculate the selling price of the rolled sole with leeks and the mushroom soufflé. (4)
- 3.2.3 Give ONE example of a fixed cost that the owner will incur when preparing the main course above. (1)
- 3.2.4 List THREE other costs that the owner should include when calculating net profit. (3)

3.3 Study the menu below and answer the questions that follow.

<p>MENU FORMAL DINNER</p> <p>Prawn Cocktail</p> <p>*****</p> <p>Consommé Royale</p> <p>*****</p> <p>Beef Wellington with Red Wine Sauce Duchess Potatoes Glazed Vegetables</p> <p>*****</p> <p>Mixed Berry Jelly</p> <p>*****</p> <p>Tea/ Coffee</p> <p>20/03/2013 R120</p>	
--	--

- 3.3.1 Evaluate to what extent you consider the menu above to be suitable for people with a high cholesterol level. Motivate your answer. (4)
- 3.3.2 Recommend a suitable cover for the menu above. (1)
- 3.3.3 Explain why the menu above is suitable for a formal dinner. (3)
- 3.3.4 Identify TWO dishes that you will NOT serve to Muslim guests and explain why. (4)
- [40]**

SECTION C: FOOD PREPARATION

QUESTION 4

4.1 Study the extract and the sketch of the beef carcass below and answer the questions that follow.

<p>DISH A TOMATO BREDIE</p> <p>(Cubed beef, tomato and onion stew served with rice)</p>	<p>DISH B GRILLED T-BONE</p> <p>(A delicious matured T-bone served with baked potato and fried onion rings)</p>	<p>DISH C VEGETARIAN BURGER</p> <p>(A tasty textured vegetable protein patty with cheese and tomato on a crispy roll)</p>
---	---	---

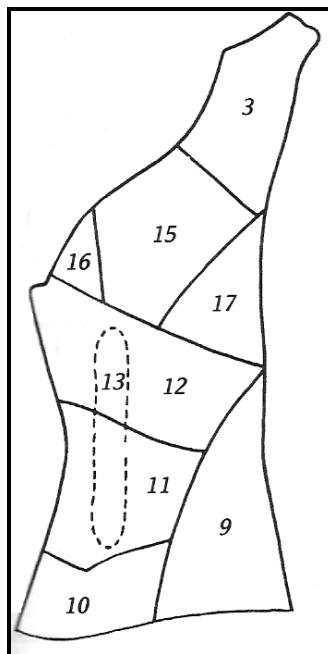

4.1.1 Identify TWO cuts from the hind quarter above that would be suitable for the tomato bredie and ONE cut suitable for the T-bone. Write down the number and name of the cut next to each dish. Tabulate your answer as follows:

DISH	CUT NUMBER	NAME OF CUT
Tomato bredie	(1)	(1)
	(1)	(1)
Grilled T-bone	(1)	(1)

(6)

4.1.2 Explain TWO advantages of maturing the T-bone.

(2)

4.1.3 State the appearance of the interior of the T-bone when it is cooked to the rare stage.

(1)

- 4.1.4 Explain how the meat becomes tender in the bredie as a result of the cooking process. (2)
- 4.1.5 Suggest TWO traditional African starch dishes that can replace the rice served with the tomato bredie. (2)
- 4.1.6 Identify the legume used in the vegetarian burger. (1)
- 4.1.7 Discuss THREE advantages of using textured vegetable protein. (3)
- 4.1.8 Explain the procedure that should be followed when receiving deliveries for perishable items before the preparation of the menus above. (5)

4.2 Explain to the new chefs the difference between choux pastry and short crust pastry with regard to the aspects listed in the table below. Tabulate your answer as follows:

		CHOUX PASTRY	SHORT CRUST PASTRY
4.2.1	Temperature of ingredients used in initial preparation	(1)	(1)
4.2.2	Proportion of flour to butter	(1)	(1)
4.2.3	Appearance of successful product	(1)	(1)
4.2.4	ONE sweet filling for each product	(1)	(1)

(8)

4.3 Study the desserts below and answer the questions that follow.

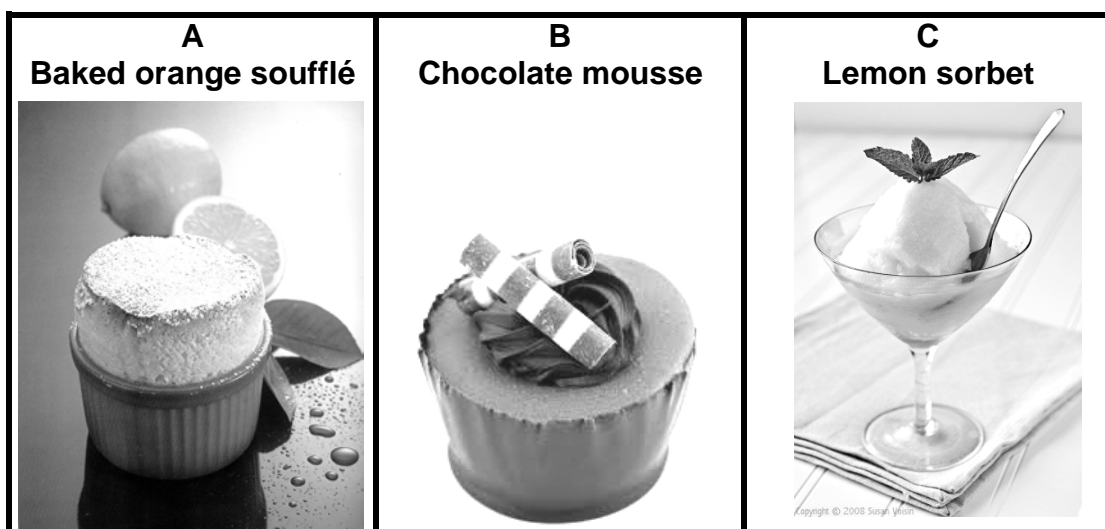

- 4.3.1 Identify a common ingredient that can be used in dessert **A** and dessert **B**. (1)

- 4.3.2 Two thousand guests are invited to a banquet. A three-course plated meal will be served.
- Select a suitable dessert from QUESTION 4.3 for the banquet and give TWO reasons for your choice. (3)
- 4.3.3 Explain why lemon sorbet is served to guests in between meals. (2)
- 4.3.4 Name TWO ingredients used in the preparation of dessert **C**. (2)
- 4.3.5 Recommend TWO types of glasses that can be used to serve the lemon sorbet. (2)
- [40]**
- TOTAL SECTION C: 80**

SECTION D: FOOD AND BEVERAGE SERVICE**QUESTION 5**

5.1 Study the picture below and answer the questions that follow.

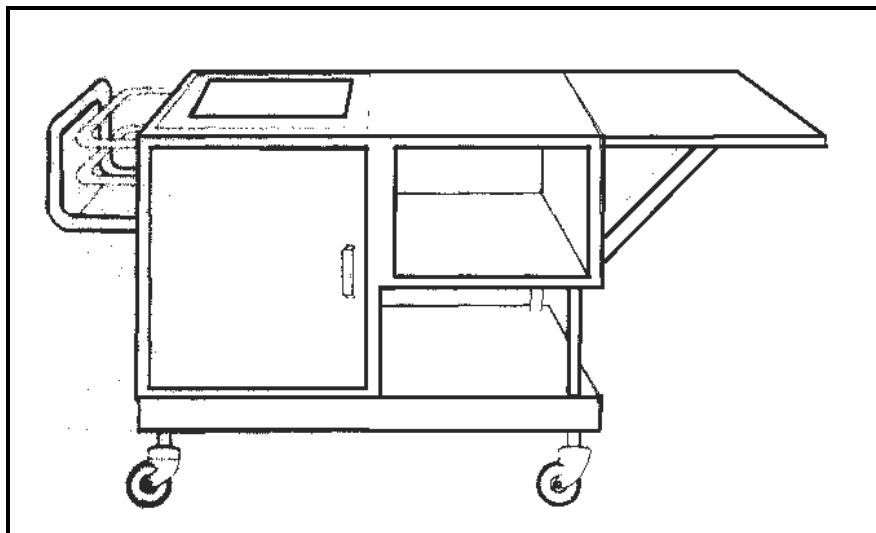

5.1.1 Explain the term *flambé*. (1)

5.1.2 Identify the equipment above. (1)

5.1.3 Do you consider the serving style above expensive or not? (2)
Motive your answer.

5.2 Match the glasses below with wines listed in 5.2.1 to 5.2.3.

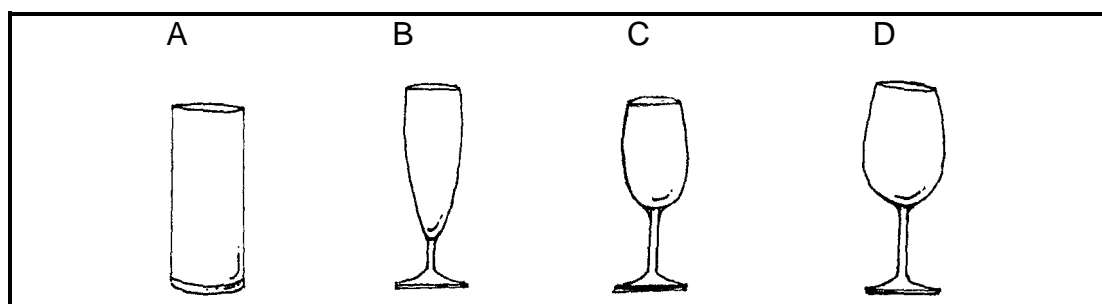

5.2.1 Shiraz (1)

5.2.2 Sparkling wine (1)

5.2.3 Chenin Blanc (1)

5.3 The menu below was offered at a wedding function. Study the menu and answer the questions that follow.

<p>MENU Wedding Reception</p> <p>Butternut Soup with Croutons</p> <p>*****</p> <p>Beef Skewers or Chicken Roulade Couscous with Almonds Medley of Vegetables</p> <p>*****</p> <p>Ice Cream and Chocolate Sauce</p> <p>March 2013</p>
--

5.3.1 Classify the wine below and identify a suitable dish from the menu that you will serve it with. Tabulate your answer as follows:

WINE	CLASSIFICATION	DISH
A Chardonnay		
B Cabernet Sauvignon		

(4)

5.3.2 Name the equipment that can be used to keep the food warm.

(1)

5.3.3 List FOUR cutlery items that you will use when setting the cover of the menu above.

(4)

5.3.4 Describe how the following tasks should be performed:

A Cleaning glasses before the function

(2)

B Storing glasses after the function

(2)

5.3.5 Explain how the waiters should perform the following procedures:

A Taking food orders

(4)

B Taking beverages to the table

(3)

C Crumbing down

(3)

- 5.4 The drink below is served in a restaurant. Study the pictures labelled **A** and **B** and answer the questions that follow.

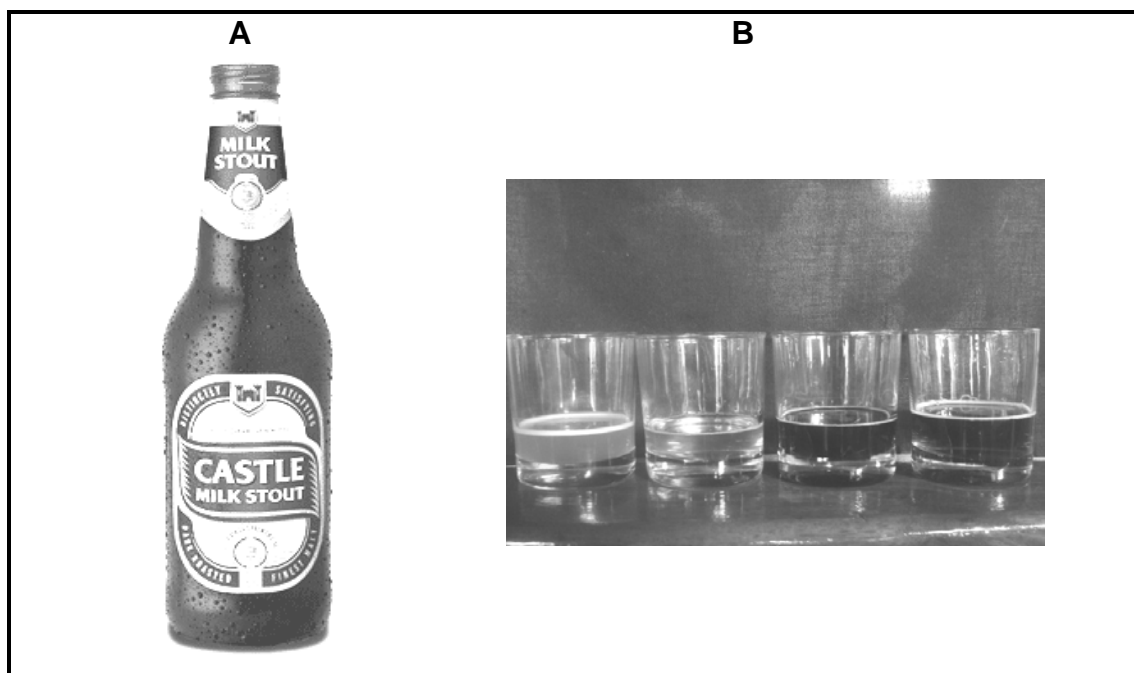

- 5.4.1 Identify the type of drink labelled **A**. (1)
- 5.4.2 Evaluate the suitability of the glasses labelled **B** for the drink labelled **A**. (2)
- 5.4.3 When the drink labelled **A** was poured into a glass it did not form a crown. Explain why this happened. (2)
- 5.5 Explain the procedure that should be followed when storing crockery. (5)

TOTAL SECTION D: 40
GRAND TOTAL: 200

ANSWER SHEET

CENTRE NUMBER:

--	--	--	--	--	--	--	--	--	--

EXAMINATION NUMBER:

--	--	--	--	--	--	--	--	--	--	--	--	--	--

**SECTION A
QUESTIONS 1**

1.1 MULTIPLE-CHOICE QUESTIONS

1.1.1	A	B	C	D
1.1.2	A	B	C	D
1.1.3	A	B	C	D
1.1.4	A	B	C	D
1.1.5	A	B	C	D
1.1.6	A	B	C	D
1.1.7	A	B	C	D
1.1.8	A	B	C	D
1.1.9	A	B	C	D
1.1.10	A	B	C	D

(10)

1.4 SEQUENCE: RECEIVING QUESTS

(5)

1.2 MATCHING ITEMS

1.2.1	
1.2.2	
1.2.3	
1.2.4	
1.2.5	

(5)

1.5 ONE-WORD ITEMS

1.5.1	
1.5.2	
1.5.3	
1.5.4	
1.5.5	
1.5.6	
1.5.7	
1.5.8	
1.5.9	
1.5.10	

(10)

1.3 MISSING WORDS

1.3.1	
1.3.2	
1.3.3	
1.3.4	
1.3.5	
1.3.6	
1.3.7	
1.3.8	
1.3.9	
1.3.10	

(10)

TOTAL SECTION A: 40