



basic education

Department:
Basic Education
REPUBLIC OF SOUTH AFRICA

CIVIL TECHNOLOGY

GUIDELINES FOR PRACTICAL ASSESSMENT TASKS

GRADE 10

2016

These guidelines consist of 25 pages.

TABLE OF CONTENTS

SECTION 1	3
1. INTRODUCTION	3
SECTION 2	3
2. GUIDELINES FOR THE TEACHER	3
2.1 The structure of the PAT for Civil Technology	3
2.2 Management of the PAT	3
2.3 Administration of the PAT	4
2.4 Assessment and moderation of the PAT	4
2.5 Assessment	4
2.6 Moderation	4
SECTION 3	5
3. GUIDELINES FOR THE LEARNER	5
3.1 Instructions to the Learner	5
3.2 Civil Services Tasks	6
3.2.1 Simulation 1	6
3.2.2 Simulation 2	7
3.2.3 Model	8
3.3 Construction Tasks	9
3.3.1 Simulation 1	9
3.3.2 Simulation 2	10
3.3.3 Model	11
3.4 Woodworking Tasks	12
3.4.1 Simulation 1	12
3.4.2 Simulation 2	13
3.4.3 Model	14
3.5 Tools for Assessment	16
3.5.1 Marking rubric for the portfolio	16
3.5.2 Marking memorandum for Civil Services working drawings	18
3.5.3 Marking memorandum for Construction working drawings	19
3.5.4 Marking memorandum for Woodworking working drawings	20
3.5.5 Marking rubric for the model	21
3.5.6 Composite mark sheet	22
SECTION 4	23
4. OTHER RELEVANT INFORMATION	23
4.1 Absence/Non-submission of task (What are the consequences?)	23
4.2 Requirements for presentation	23
4.3 Time frames	23
4.4 Declaration of authenticity	24
SECTION 5	
5. CONCLUSION	25

SECTION 1

1. INTRODUCTION

The 16 Curriculum and Assessment Policy Statement subjects which contain a practical component all include a practical assessment task (PAT). These subjects are:

- **AGRICULTURE:** Agricultural Management Practices, Agricultural Technology
- **ARTS:** Dance Studies, Design, Dramatic Arts, Music, Visual Arts
- **SCIENCES:** Computer Applications Technology, Information Technology
- **SERVICES:** Consumer Studies, Hospitality Studies, Tourism
- **TECHNOLOGY:** Civil Technology, Electrical Technology, Mechanical Technology and Engineering Graphics and Design.

A practical assessment task (PAT) mark is a compulsory component of the final promotion mark for all candidates offering subjects that have a practical component and counts 25% (100 marks) of the end-of-year examination mark. The PAT is implemented across the first three terms of the school year. This is broken down into different phases or a series of smaller activities that make up the PAT. The PAT allows for learners to be assessed on a regular basis during the school year and it also allows for the assessment of skills that cannot be assessed in a written format, e.g. test or examination. It is therefore important that schools ensure that all learners complete the practical assessment tasks within the stipulated period to ensure that learners are resulted at the end of the school year. The planning and execution of the PAT differs from subject to subject.

SECTION 2

2. GUIDELINES FOR THE TEACHER

(These guidelines must be explained clearly to the learners.)

2.1 The structure of the PAT for Civil Technology

The PAT accounts for the skills the learner has mastered. This is assessed at intervals and requires the learner to engage in multiple practical sessions. During these weekly sessions, skills such as simulation, experimentation, hand skills, tool skills, machine skills and workshop practice are honed and perfected to the point where the learner may engage in the tasks set out for that particular term. The PAT accounts for 25% of the learner's promotion mark.

2.2 Management of the PAT

The PAT should commence in term 1, as this is a lengthy and drawn out process and **CANNOT** be left to the last minute.

- (a) All the components of the PAT (simulations, portfolio, working drawings and model) should be completed and presented for assessment by the end of **August** to allow sufficient time for the external moderation.
- (b) During this phase, the teacher will do any final assessments that are outstanding. All learner portfolios, working drawings and models are kept safely until the moderation process is completed (both provincial and national moderation).
- (c) **The internal moderator/HOD must conduct moderation of the PAT throughout the year.**
- (d) It is imperative that the criteria are adhered to from the beginning, as this will form the basis for assessment.
- (e) Teachers cannot penalise learners on points that are not included in the initial criteria.
- (f) When learners are selected during moderation (face moderation), they may be required to showcase their skills and knowledge.

All teachers must design a pacesetter to indicate the completion dates for the different stages of the PAT. The teacher must manage this process to avoid crisis management and unnecessary stress closer to the completion date of the PAT.

The submission dates for the different sections of the PAT, as indicated in the pacesetter, should be given to the learners in writing.

2.3 Administration of the PAT

The PAT should be based on real-life situations and completed under controlled conditions.

Teachers must set dates for the completion of the different phases of the PAT. In this manner learners can assess their progress. In instances where formal assessment tasks take place, it is the responsibility of the teacher to administer assessment tasks.

After studying the guidelines teachers must fully explain the requirements of the different stages of the PAT and the criteria, as indicated in the rubrics and mark schedules, to the learners. This will ensure that learners and teachers have a common understanding of the assessment tools and what is expected of the learners.

Teachers are requested to make copies of **SECTIONS 3 TO 5** of this document and hand it to the learners not later than the **first week in February**.

The products/models should not leave the classroom/workshop and must be kept in a safe place at all times when learners are not working on them.

2.4 Assessment and moderation of the PAT

The PAT for Grade 10 is internally set and externally moderated, but internally assessed by the teacher and moderated by the internal moderator/HOD.

2.5 Assessment

Frequent developmental feedback is needed to guide and support to the learner to ensure that the learner is on the right track.

Both formal and informal assessment should be conducted on the different tasks that constitute the PAT. Informal assessment may be conducted by the learner himself or herself, by a peer group, or by the teacher. Formal assessment should always be conducted by the teacher and the results will be recorded.

The teacher must take into account the requirements of the assessment of all the components of the PAT and therefore plan the assessment programme of the PAT accordingly.

2.6 Moderation

During moderation of the PAT the simulations, portfolio, working drawings and the model must be presented to the external moderator.

Where required the moderator should be able to call on the learner to explain the function and principles of operation and also request the learner to exhibit the skills acquired through the capability tasks for moderation purposes. The sequence of events of the technological process may also be requested from the learner.

SECTION 3**3. GUIDELINES FOR THE LEARNER**

Learner's name: _____

Time Allowed: 1st to 3rd term

3.1 Instructions to the learner

- This practical assessment task counts 25% of your final promotion mark.
- All work you produce must be your own effort.
- All sources used must be acknowledged.
- Use your discretion where dimensions and/or information have been excluded.
- Calculations should be clear and include units.
- Calculations should be rounded off to TWO digits.
- Drawings may be hand-drawn (use drawing instruments) or drawn on CAD. NO photocopies or scanned files of drawings are allowed.
- Photographs and scanned photographs may be used and may be in colour or greyscale.
- SI units should be used.
- You are encouraged to use recycled materials to make the model.
- Changes during simulation of the product should be documented and included in the design portfolio.
- Your assignment and assessment instruments should be placed at the back of the design portfolio.
- The marking memorandum for the working drawings must be attached to your working drawings.
- Where available you may use electronic equipment, e.g. cellphones, cameras, digital cameras, etc. to document your progress.
- **The product/model should not leave the classroom/workshop and must be kept in a safe place at all times when you are not working on it.**

The practical assessment task (PAT) consists of TWO simulations, portfolio, working drawings and a product/model to be completed over three terms.

Computer-aided drawings should be done under the supervision of the teacher.

3.2 Civil Services Tasks

3.2.1 Simulation 1: Cutting and joining copper pipes

Materials needed:

- Ø 15 mm copper pipe class 0
- Ø 15 mm copper elbow
- Soldering wire
- Flux

Instructions:

- Cut one piece of copper pipe to a length of 100 mm using a hacksaw.
- Cut one piece of copper pipe to a length of 50 mm using a pipe cutter.
- Ream and clean ends to be soldered.
- Apply flux to pipe and elbow using a brush.
- Solder joint on both sides of elbow.

Facet sheet

Criteria	Marks	LM
Cut pipe to length of 100 mm using hacksaw. (<i>Correct length and straightness of cut</i>)	2	
Cut pipe to length of 50 mm using pipe cutter. (<i>Correct length and straightness of cut</i>)	2	
Ream and clean ends of pipe to be soldered. (<i>Ream and clean pipe correctly</i>)	2	
Apply flux correctly using a brush. (<i>Apply flux to pipe and elbow correctly</i>)	2	
Light soldering torch. (<i>Light soldering torch correctly and safely</i>)	2	
Solder joint (<i>Use soldering torch and soldering wire correctly, no excess solder on joint or pipe</i>)	3	
Use the correct length of soldering wire for the joint.	2	
Clean joint (<i>Correct cleaning of joint</i>)	2	
Neatness of joint	3	
Total	20	

Completed joint to be available for moderation.

3.2.2 Simulation 2: Sheet metal joints (Pop rivet joint)

Materials needed:

- TWO pieces of galvanized sheet metal (100 mm x 100 mm)
- FIVE pop rivets (Ø 4 mm). Length of the rivet must be appropriate for the material thickness used.

Instructions:

- Cut TWO pieces of galvanized sheet metal (100 mm x 100 mm)
- The two pieces of sheet metal must overlap 10 mm when joined.
- The two pieces of sheet metal must be joined to each other with FIVE rivets which are equally spaced.

Facet sheet

Criteria	Marks	LM
Mark TWO pieces of galvanized sheet metal (100 mm x 100 mm). (<i>Correct size and straightness of lines</i>)	2	
Cut TWO pieces of galvanized sheet metal (100 mm x 100 mm). (<i>Correct size and straightness of cut</i>)	2	
Mark 10 mm for overlap on both sheets. (<i>Accuracy and squareness of lines</i>)	2	
Mark 5 mm from the side for centre lines of holes for pop rivets on both sheets. (<i>Accuracy and squareness of lines</i>)	2	
Mark 5 holes equally spaced on both sheets.	2	
Use a centre punch and punch marks where holes must be drilled.	1	
Drill holes Ø 4 mm in both sheets, as marked.	5	
Insert rivets in holes and rivet two sheets together.	2	
Neatness of joint.	2	
Total	20	

Completed joint to be available for moderation.

3.2.3 Model (Civil Services)

Instructions:

Learners should use discretion where details have been omitted.
Develop and compile a portfolio to show the following.

- Cover page
- Table of contents
- Declaration of authenticity
- Research
 - Properties of galvanised sheet metal
 - Sizes of galvanised sheet metal sheets
 - Different types of sheet metal joints that may be used to join sheet metal
- A list of tools to make the container
- A list of materials to make the container

The figure below shows a drawing of a sheet metal container.

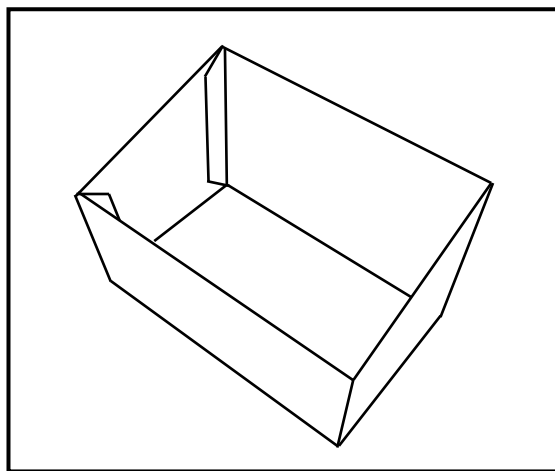

SHEET METAL CONTAINER

Use the marking memorandum for the drawings as a guide and draw the following:

- The front, left and top view of this container in first-angle orthographic projection to scale 1 : 2
- The pattern development of this container to use as a template to make this model. Use scale 1 : 1.

Specifications:

- Height at the back 100 mm
- Height in front 70 mm
- Length 200 mm
- Width 80 mm
- Overlap for joints 10 mm
- Use appropriate sheet metal joints

Model:

Make the container from galvanised sheet metal, to scale 1 : 1, using the specifications above.

3.3 Construction Tasks

3.3.1 Simulation 1: Transfer levels using a transparent pipe level, a spirit level and a straight edge.

Tools and materials needed:

- Ø 15 mm transparent pipe (5 m long)
- 4 x Ø 10 mm steel pegs (400 mm long)
- Spirit level
- Straight edge
- Hammer
- Measuring tape

Task:

- Hammer one peg into the ground.
- Hammer a second peg into the ground, 4,5 m away from the first.
- Use the transparent pipe filled with water and align the top of the second peg to the first (transfer the level of peg 1 to peg 2).
- Hammer pegs into the ground at intervals of just less than the length of the straight edge between the first and last peg.
- Use a spirit level on top of the straight edge and set the top of each peg to the same height as that of the first peg (do not adjust the last peg after the level of peg 1 was transferred using the transparent pipe).
- Compare the two methods used in terms of accuracy and time taken to transfer the levels. Use the table below.

	ACCURACY	TIME
Transparent pipe		
Spirit level and straight edge		

Facet sheet

Criteria	Marks	LM
Hammer two pegs into the ground, 4,5 m apart.	2	
Fill transparent pipe with water. (<i>Ensure that all air bubbles have been removed from the pipe</i>)	3	
Transfer the level of peg 1 to peg 2 using transparent pipe	5	
Hammer pegs into the ground at intervals of just less than the length of the straight edge between the first and last peg.	3	
Use a spirit level on top of the straight edge and set the top of each peg to the same height as that of the first peg	3	
Compare the two methods using table provided.	4	
Total	20	

Take photographs to provide as evidence. Face moderation may be done.

3.3.1 Simulation 2: Dry packing of bricks in stretcher bond

Materials needed:

- Bricks
- Chalk/Chalk line to mark out on floor

Instructions:

- Dry packing of corner joint (quoin) – one brick wide and 5 courses high
- The alternate plan courses
- One end should show tothing and the other end should show raking back

FIGURE 3.3.2 below shows the corner joint, tothing and raking back.

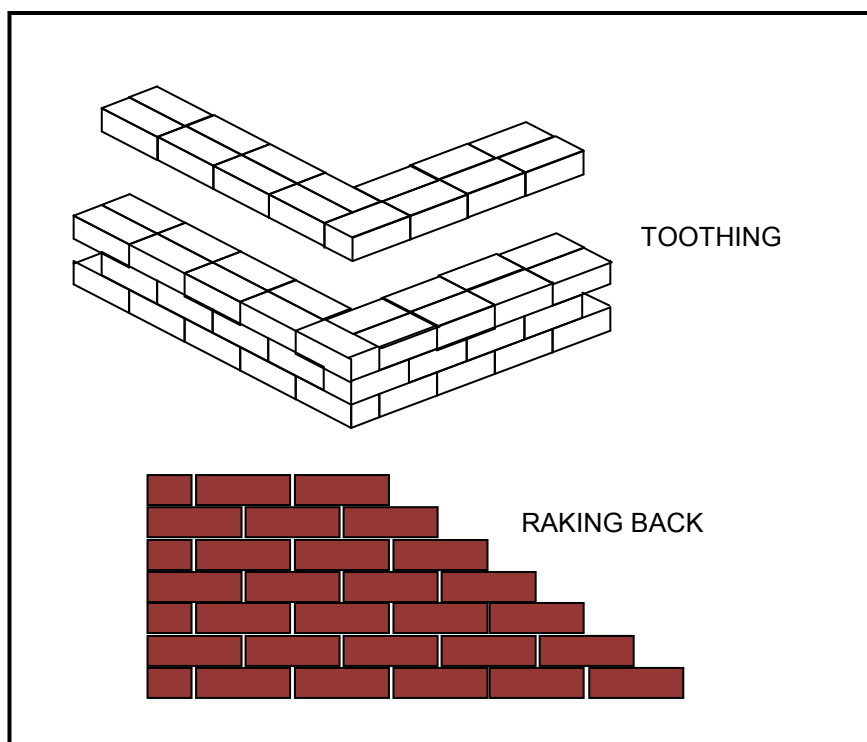

FIGURE 3.3.2

Facet sheet

Criteria	Marks	LM
Measure out on the floor for the dry packing (one-brick wide quoin).	4	
Packing of 5 courses	4	
Bond at the corner of the wall	4	
Tothing done correctly	4	
Raking back done correctly	4	
Total	20	

Take photos to provide as evidence. Face moderation may be done.

3.3.3 Model (Construction)

Instructions:

Learners should use discretion where details have been omitted. Develop and compile a portfolio to show the following:

- Cover page
- Table of contents
- Declaration of authenticity
- Research:
 - Definition of formwork and striking of formwork
 - Purpose of formwork
 - Different types of materials used for the formwork of a square column
- A list of tools to make the formwork of a square column
- A list of materials to make the formwork of a square column

FIGURE 3.3.3 shows an illustration of the formwork of a square column.

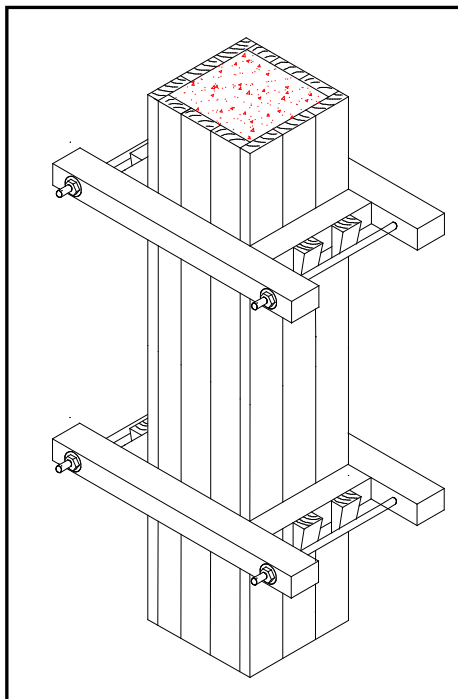

FIGURE 3.3.3

Use the marking memorandum for the drawings as a guide and draw the following:

- The front, left and top view of the formwork of a square column in first-angle orthographic projection to scale 1 : 2
- A horizontal sectional view of the formwork for a 300 mm square column. Use scale 1 : 5 and show ALL relevant detail.

Specifications:

- Concrete column 300 mm x 300 mm
- Height of formwork 500 mm
- Show at least TWO sets of clamps
- Use timber for the formwork
- Brace the column on TWO sides

Model:

Make the formwork for a square column to scale 1 : 1, using the specifications above.

3.4 Woodworking

3.4.1 Simulation 1: Bench hook

Materials needed:

- 2 x 140 x 40 x 20 mm stopped ends
- 1 x 250 x 200 x 20 mm base
- 4 x 38 mm x 8 mm screws

Instructions:

- Measure and cut two pieces of timber for the stopped ends using a tenon saw.
- Measure and cut one piece of timber for the base using a crosscut saw.
- Measure and drill two holes on each of the stopped ends for the screws.

Mark the position of the stopped ends on the base and screw the stopped ends to the base.

Facet sheet

Criteria	Marks	LM
Cut two pieces of timber (stopped ends) 140 mm long using a tenon saw. <i>(Correct length and squareness of cut)</i>	4	
Cut one piece of timber (base) 250 mm long using a cross cut saw. <i>(Correct length and squareness of cut)</i>	4	
Measure and drill two holes on each of the stopped ends for the screws.	5	
Mark position of stopped end and screw onto base.	5	
Neatness of joints	2	
Total	20	

Completed simulation should be available for moderation.

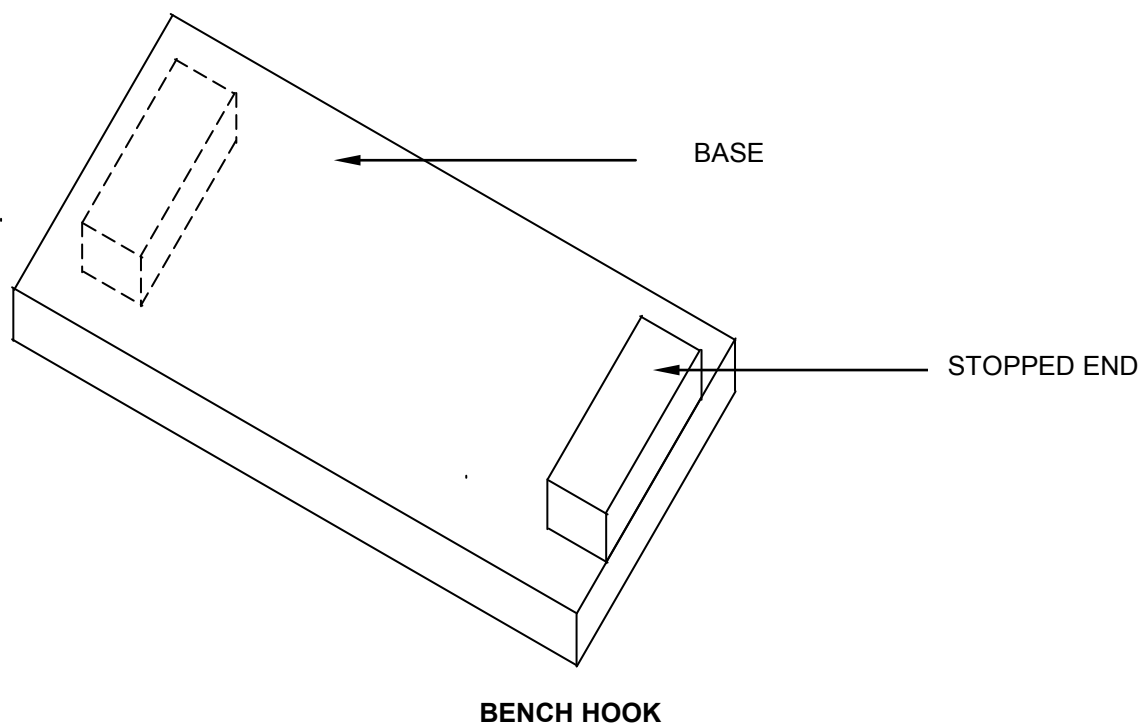

3.4.2 Simulation 2: Finger joint (book ends), dowel joint, butt joint, half lap joint

Materials needed:

- 4 x 150 x 120 x 20 mm base and sides
- 2 x 100 x 80 x 20 mm cleat

Instructions:

- Measure and cut four pieces of timber for the base and sides using a tenon saw.
- Measure and mark for pins and sockets on two pieces for a finger joint.
- Cut and remove the sockets using a dovetail saw and chisel.
- Sandpaper all parts and assemble the two pieces.
- Measure and mark for pins and sockets on two pieces for a dowel joint.
- Drill three holes on each of the two pieces for the dowels using a dowelling jig.
- Cut three dowels to suit the length of the holes of the two pieces.
- Cut a groove along the length of each dowel.
- Sandpaper all parts and assemble the two pieces.
- Develop a pattern for the cleats and cut to shape.
- Sandpaper the two pieces and assemble each one on the dowel and finger joint.

Facet sheet

Criteria	Marks	LM
Measure and cut four pieces of timber for the base and sides using a tenon saw.	2	
Measure and mark for pins and sockets on two pieces for a finger joint.	2	
Cut and remove the sockets using a dovetail joint and chisel.	2	
Sandpaper all parts and assemble the two pieces.	2	
Measure and mark for pins and sockets on two pieces for a dowel joint.	2	
Drill three holes on each of the two pieces for the dowels using a dowelling jig.	2	
Cut three dowels to suit the length of the holes of the two pieces.	2	
Cut a groove along the length of each dowel.	1	
Sandpaper all parts and assemble the two pieces.	2	
Develop a pattern for the cleats and cut to shape.	2	
Sandpaper the two pieces and assemble each one on the dowel and finger joint.	1	
Total	20	

Completed joint should be available for moderation.

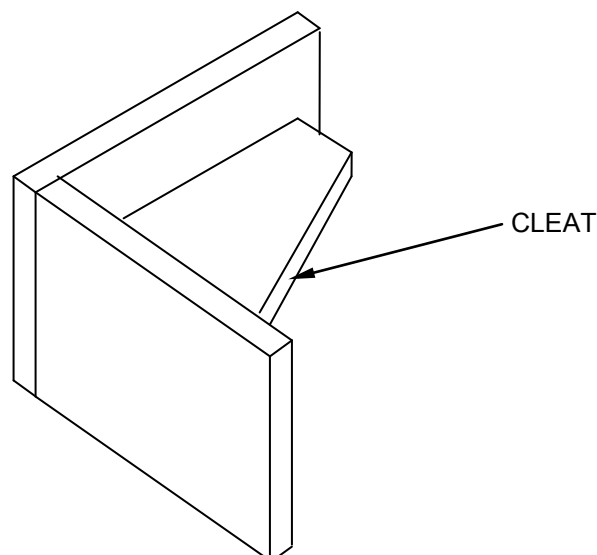

3.4.3 Model (Woodworking): Tool Caddy

Instructions:

Learners should use discretion where details have been omitted.

Develop and compile a portfolio to show the following:

- Cover page
- Table of contents
- Declaration of authenticity
- Research:
 - Differentiate between the properties of fabricated board and solid timber
 - Different types of joints that may be used to make a tool caddy
 - Different types of materials that may be used to make a tool caddy
- A list of tools to make the tool caddy
- A list of materials to make the tool caddy

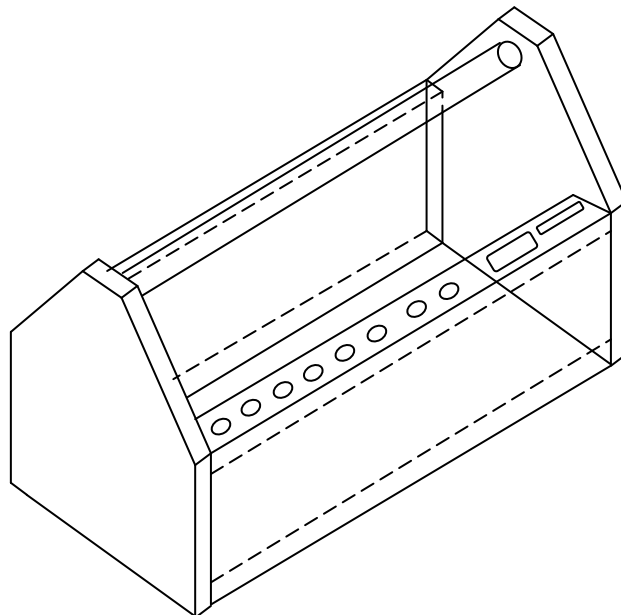

Use the marking memorandum for the drawings as a guide and draw the following:

- The front, left and top view of the tool caddy in first angle orthographic projection to scale 1 : 2
- A vertical cross section of the tool caddy. Use scale 1 : 2 and show ALL relevant detail.

Specifications:

- 2 x 250 mm x 400 mm x 20 mm ends
- 1 x 250 mm x 450 mm x 20 mm bottom/base
- 2 x 120 mm x 450 mm x 20 mm sides
- 1 x 50 mm x 20 mm rail with holes and slots for chisels, screwdrivers and awls
- 1 x 500 mm material for handle (broomstick or chamfered edges of piece of wood)

Model:

Make the tool caddy using the following instructions:

- Measure and cut to shape the two pieces of timber for the ends.
- Rebate bottom and sides of ends to house the bottom and sides of tool caddy
- Measure and cut sides and bottom to size.
- Mark and form rebate on ends to accommodate handle.
- Assemble all parts, including the handle.
- Measure and cut rail to fit between ends and fix onto tool caddy.
- Mark out holes on rail for screwdrivers, chisels, awls, squares, etc.
- Drill the holes for screwdrivers, chisels, awls, squares, etc. and fix the rail onto tool caddy.
- Sandpaper the model to remove all sharp corners.

3.5 Tools for assessment

3.5.1 Rubric for assessment of the portfolio

CRITERIA		Level 4	Level 3	Level 2	Level 1	Level 0
		80–100%	50–79%	30–49%	1–29%	0%
Presentation	Cover page	Six of the following done neatly: <ul style="list-style-type: none"> Name of school Name of learner Name of teacher Grade Year Appropriate title Appropriate illustration 	Five of the following done neatly: <ul style="list-style-type: none"> Name of school Name of learner Name of teacher Grade Year Appropriate title Appropriate illustration 	Four of the following done neatly: <ul style="list-style-type: none"> Name of school Name of learner Name of teacher Grade Year Appropriate title Appropriate illustration 	Template used. Fewer than four of the following done neatly: <ul style="list-style-type: none"> Name of school Name of learner Name of teacher Grade Year Appropriate title Appropriate illustration 	Not attempted.
	Level x 1	Level 4	Level 3	Level 2	Level 1	Level 0
	Table of contents	All the following done correctly and neatly: <ul style="list-style-type: none"> Sections Subsections Page numbers Page numbers correspond with content 	Three of the following done correctly and neatly: <ul style="list-style-type: none"> Sections Subsections Page numbers Page numbers correspond with content 	Two of the following done correctly and neatly: <ul style="list-style-type: none"> Sections Subsections Page numbers Page numbers correspond with content 	One of the following done correctly and neatly: <ul style="list-style-type: none"> Sections Subsections Page numbers Page numbers correspond with content 	Not attempted.
	Level x 1	Level 4	Level 3	Level 2	Level 1	Level 0
	Declaration of authenticity	Included in portfolio, signed by both the teacher and learner with school stamp.	Included in portfolio, signed by both the teacher and learner but not stamped.	Included in portfolio but only signed by the teacher.	Included in portfolio but not signed by both the teacher and learner.	Not included in portfolio.
Level x 1	Level 4	Level 3	Level 2	Level 1	Level 0	
Content of portfolio	Evidence	All aspects as required are included in the portfolio: Research, working drawings, marking memorandum for drawings, completed mark sheets for the portfolio and model and for both simulations.	All aspects as required are included in the portfolio: Research, working drawings, marking memorandum for drawings, completed mark sheets for the portfolio and model.	All aspects as required are included in the portfolio: Research, working drawings, marking memorandum for drawings.	All aspects as required are included in the portfolio: Research, working drawings.	No evidence
	Level x 1	Level 4	Level 3	Level 2	Level 1	Level 0

CRITERIA		Level 4 80–100%	Level 3 50–79%	Level 2 30–49%	Level 1 1–29%	Level 0 0%
Tools and material to make the container	List of tools	MORE than ADQUATE hand and power tools are indicated correctly in an orderly manner extremely neat under different headings.	ADQUATE hand and power tools are indicated correctly in an orderly and neat manner under different headings.	LESS than ADQUATE hand and power tools are indicated satisfactorily in an orderly and neat manner under different headings.	EXTREMELY FEW hand and power tools are indicated in an untidy manner without different headings.	Not attempted
	Level x 1	Level 4	Level 3	Level 2	Level 1	Level 0
	List of materials	MORE than ADQUATE materials are indicated correctly in an orderly manner extremely neat under different headings.	ADQUATE materials are indicated correctly in an orderly and neat manner under different headings.	LESS than ADQUATE materials are indicated satisfactorily in an orderly and neat manner under different headings.	EXTREMELY FEW materials are indicated in an untidy manner without different headings.	Not attempted
Level x 1	Level 4	Level 3	Level 2	Level 1	Level 0	

CRITERIA		Level 4 80–100%	Level 3 50–79%	Level 2 30–49%	Level 1 1–29%	Level 0 0%
Adherence to deadlines	Adherence to deadlines	Design portfolio submitted BEFORE OR ON due date.	Design portfolio submitted ONE TO THREE days late.	Design portfolio submitted FOUR TO SIX days late.	Design portfolio submitted later than SEVEN OR MORE days.	Not attempted
	Level x 1	Level 4	Level 3	Level 2	Level 1	Level 0

3.5.2 **Marking memorandum for the working drawings (CIVIL SERVICES)**

Learner's name: _____ Grade: 10 _____

SCALE DRAWINGS	ASSESSMENT CRITERIA	MARK ALLOCATION			LEARNER MARK
		Good	Average	Poor/ Not done	
DRAWING 1 ORTHOGRAPHIC DRAWINGS	Front view	4–5	2–3	0–1	
	Top view	3–4	2	0–1	
	Left view	3–4	2	0–1	
	Hidden details	3–4	2	0–1	
	Use of correct line types (outside lines and construction lines)	3–4	2	0–1	
	Dimensions	3	2	0–1	
	Title and scale	2	1	0	
	Application of scale	3–4	2	0–1	
SUBTOTAL		30			
DRAWING 2 PATTERN DEVELOPMENT	Pattern correctly developed	8–14	4–7	0–3	
	Application of scale	3–4	2	0–1	
	Title and scale	2	1	0	
SUBTOTAL		20			
TOTAL		50			
CONVERTED TO		10			

NOTE: The teacher should draw a mask to mark these drawings.

3.5.3 **Marking memorandum for the working drawings (CONSTRUCTION)**

Learner's name: _____ Grade: 10 _____

SCALE DRAWINGS	ASSESSMENT CRITERIA	MARK ALLOCATION			LEARNER MARK
		Good	Average	Poor/ Not done	
DRAWING 1 ORTHOGRAPHIC DRAWINGS	Front view	4–5	2–3	0–1	
	Top view	3–4	2	0–1	
	Left view	3–4	2	0–1	
	Hidden details	3–4	2	0–1	
	Use of correct line types (outside lines and construction lines)	3–4	2	0–1	
	Dimensions	3	2	0–1	
	Title and scale	2	1	0	
	Application of scale	3–4	2	0–1	
SUBTOTAL		30			
HORIZONTAL CROSS SECTION OF FORMWORK	Column drawn correctly	2	1	0	
	Shuttering drawn correctly	2	1	0	
	Clamps drawn correctly	3–4	2	0–1	
	Yokes drawn correctly	3–4	2	0–1	
	Wedges drawn correctly	2	1	0	
	Threaded rods, washers and nuts drawn correctly	2	1	0	
	Print title and scale	2	1	0	
	Application of scale	2	1	0	
SUBTOTAL		20			
TOTAL		50			
CONVERTED TO		10			

NOTE: The teacher should draw a mask to mark these drawings.

3.5.4 **Marking memorandum for the working drawings (WOODWORKING)**

Learner's name: _____ Grade: 10 _____

SCALE DRAWINGS	ASSESSMENT CRITERIA	MARK ALLOCATION			LEARNER MARK
		Good	Average	Poor/ Not done	
DRAWING 1 ORTHOGRAPHIC DRAWINGS	Front view	4–5	2–3	0–1	
	Top view	3–4	2	0–1	
	Left view	3–4	2	0–1	
	Hidden details	3–4	2	0–1	
	Use of correct line types (outside lines and construction lines)	3–4	2	0–1	
	Dimensions	3	2	0–1	
	Title and scale	2	1	0	
	Application of scale	3–4	2	0–1	
SUBTOTAL		30			
VERTICAL CROSS SECTION	Sides drawn correctly	2	1	0	
	Base drawn correctly	2	1	0	
	Ends drawn correctly	3–4	2	0–1	
	Tool rail positioned and drawn correctly	3–4	2	0–1	
	Handle positioned and drawn correctly	2	1	0	
	Hidden detail for rebate of base	2	1	0	
	Print title and scale	2	1	0	
	Application of scale	2	1	0	
SUBTOTAL		20			
TOTAL		50			
CONVERTED TO		10			

NOTE: The teacher should draw a mask to mark these drawings.

3.5.5 **Rubric for assessment of the final product/model****NOTE:** 'Not presented' or 'not attempted' will receive a 0 (zero) mark.

CRITERIA		Level 4 80–100%	Level 3 50–79%	Level 2 30–49%	Level 1 1–29%	Level 0 0%
Manufacturing competency for:	Marking	Demonstrate an OUTSTANDINGLY HIGH LEVEL of skill and competence to mark the different parts of the model correctly and accurately.	Demonstrate a HIGH LEVEL of skill and competence to mark the different parts of the model correctly and accurately.	Demonstrate a SATISFACTORY LEVEL of skill and competence to mark the different parts of the model correctly and accurately.	Demonstrate an UNACCEPTABLE LEVEL of skill and competence to mark the different parts of the model correctly and accurately.	Not attempted.
	Level x 2	Level 4	Level 3	Level 2	Level 1	Level 0
	Cutting	Demonstrate an OUTSTANDINGLY HIGH LEVEL of skill and competence to cut the different parts of the model correctly and accurately.	Demonstrate a HIGH LEVEL of skill and competence to cut the different parts of the model correctly and accurately.	Demonstrate a SATISFACTORY LEVEL of skill and competence to cut the different parts of the model correctly and accurately.	Demonstrate an UNACCEPTABLE LEVEL of skill and competence to cut the different parts of the model correctly and accurately.	Not attempted.
	Level x 3	Level 4	Level 3	Level 2	Level 1	Level 0
	Assembly/Joining	Demonstrate an OUTSTANDINGLY HIGH LEVEL of skill and competence to assemble and join the different parts of the model correctly and accurately.	Demonstrate a HIGH LEVEL of skill and competence to join the different parts of the model correctly and accurately.	Demonstrate a SATISFACTORY LEVEL of skill and competence to assemble and join the different parts of the model correctly and accurately.	Demonstrate an UNACCEPTABLE LEVEL of skill and competence to assemble and join the different parts of the model correctly and accurately.	Not attempted.
	Level x 2	Level 4	Level 3	Level 2	Level 1	Level 0
	Finishing	Demonstrate an OUTSTANDINGLY HIGH LEVEL of skill and competence to finish off the different parts of the model correctly using the appropriate finishing method.	Demonstrate a HIGH LEVEL of skill and competence to finish off the different parts of the model correctly using the appropriate finishing method.	Demonstrate a SATISFACTORY LEVEL of skill and competence to finish off the different parts of the model correctly using the appropriate finishing method.	Demonstrate an UNACCEPTABLE LEVEL of skill and competence to finish off the different parts of the model correctly using the appropriate finishing method.	Not attempted.
	Level x 2	Level 4	Level 3	Level 2	Level 1	Level 0
	Overall impression	The overall appearance and surface finishing is of an OUTSTANDINGLY HIGH quality with NO obvious defects.	The overall appearance and surface finishing is of a HIGH quality with VERY FEW obvious defects.	The overall appearance and surface finishing is of a SATISFACTORY quality with EASILY observed defects.	The overall appearance and surface finishing is of a POOR quality with MANY easily observed defects.	Not attempted.
	Level x 1	Level 4	Level 3	Level 2	Level 1	Level 0

3.5.6

COMPOSITE MARK SHEET

(CIVIL SERVICES

CONSTRUCTION

WOODWORKING

No	NAME OF LEARNER	SIMULATIONS			PORTFOLIO						SCALE DRAWINGS				MODEL					TOTAL		
		SIMULATION 1	SIMULATION 2	TOTAL: 40	PRESENTATION	CONTENT OF PORTFOLIO	LIST OF TOOLS AND MATERIALS	ADHERENCE TO DEADLINES	TOTAL: 28	TOTAL: 10	DRAWING 1	DRAWING 2	TOTAL: 50	TOTAL: 10	MARKING	CUTTING	ASSEMBLY/JOINING	FINISHING	OVERALL IMPRESSION		TOTAL: 40	GRAND TOTAL: 100 (S1 + S2 +P+WD+M)
		20	20	40	12	4	8	4	28	10	30	20	50	10	8	12	8	8	4	40	100	
1																						
2																						
3																						
4																						
5																						
6																						
7																						
8																						
9																						
10																						
11																						
12																						
13																						
14																						
TOTAL																						
AVERAGE																						

Signature of (Teacher)

Date

Signature of (Moderator)

Date

SCHOOL STAMP

SECTION 4**4. OTHER RELEVANT INFORMATION****4.1 Absence/Non-submission of task (What are the consequences?)**

The absence of a practical assessment task will be dealt with in accordance with the regulations as stipulated in the *National Policy on Protocol for Assessment Grades R–12*, page 6, chapter 3, paragraphs 7 and 8.

The *National Protocol for Assessment Grades R–12*, chapter 3, paragraph 8, subsection (4) clearly states that the absence of a practical assessment task mark will result in the candidate registered for that particular subject, receiving an incomplete result.

4.2 Requirements for presentation

The following should be presented by the candidate for assessment and moderation:

- A complete design portfolio
- All scale drawings
- A completed model
- The learner's name and class must be clearly indicated on all components of the PAT

The following document should be presented by the teacher for moderation:

- A composite mark sheet (one composite mark sheet comprising all learners' names and marks for all aspects that were assessed)

4.3 Time frames**Recommended time frames for the completion of the PAT:**

Term 1:	Simulation 1:	Portfolio:
		<ul style="list-style-type: none"> • Cover page • Table of contents • Research • List of tools and equipment needed for the model • Declaration of authenticity
Term 2:	Simulation 2:	Working drawings:
		<ul style="list-style-type: none"> • All drawings as indicated on the marking memorandum. • NOTE: Use the criteria on the marking memorandum for drawings as a guide when preparing your drawings.
		Product/Model:
		Manufacturing of parts
Term 3:	Product/Model:	Manufacturing, final assembling of parts and finishing off of the model

4.4 Declaration of authenticity

NAME OF THE SCHOOL:

NAME OF LEARNER:.....

NAME OF TEACHER:

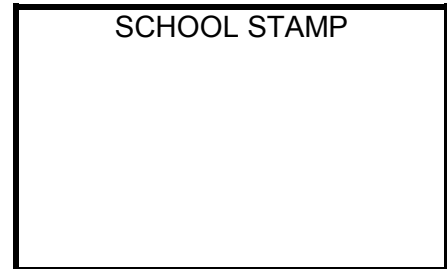

I hereby declare that the practical assessment task submitted for assessment is my own, original work and it has not been submitted for moderation previously.

SIGNATURE OF LEARNER

DATE (SUBMITTED)

As far as I know, the above declaration by the learner is true and I accept that the work offered is his/her own.

SIGNATURE OF TEACHER

DATE (ASSESSED)

SECTION 5**5. CONCLUSION**

On completion of the practical assessment task learners should be able to demonstrate their understanding of the industry, enhance their knowledge, skills, values and reasoning abilities as well as establish connections to life outside the classroom and address real world challenges. The PAT furthermore develops learner's life skills and provides opportunities for learners to engage in their own learning.