



basic education

Department:
Basic Education
REPUBLIC OF SOUTH AFRICA

TLHAHLOBO TŠA NGWAGA LE NGWAGA TŠA BOSETŠHABA

KEREITI 3

DIPALO- SEPEDI

SETE YA 3: MOHLALA 2012

TLHAGO GO TŠHOMIŠO YA MEHLALA YA MAPHEPHE A NGWAGA LE NGWAGA TŠA

BOSETŠHABA (ANA)

1. Tebelelo ka kakaretšo.

Diteko tša ngwaga le ngwaga tša Bosetšhaba (ANA) ke Kelo ya semmušo ya mafelelo yeo e lekolago tsebo le mabokgoni ao barutwana ba mphato wa 1-6 le 9 ba swanetšego go di tšweletša mafelelong a mphato wo mongwe le wo mongwe.

Go thekga Kelo yeo barutwana ba e hwetšago go tšwa sekolong, le go netefatša gore barutwana ba hwetša boitshepho bjo nyakegago gore ba tšee karolo go tšwelela go Kelo ya ka ntle, diphanele tša barutiši le ditsebi tša dithuto ba hlama mehlala ya maphephe a dipotšišo tša melekwana ao barutiši ba ka a šomišago go ruta dithuto tša Dipalo le Maleme.

Mehlala ya maphephe a dipotšišo tša melekwana ye e hlamilwego go lebeletšwe mošomo wa kharikhulamo wa kotara ya 1, 2 le 3 ya ngwaga gomme melekwana wa ANA wa mphato wo mongwe le wo mongwe o šetše o filwe dikolo. Mehlala ya maphephe, go balwa le melekwana ya ANA ga di fetole tsela yeo barutiši ba elago barutwana nako le nako, fela di thuša go tšwetša kelo ya sekolong pele.

2. Sebopego sa mehlala ya dipotšišo

Mehlala ya maphephe e diretšwe go laetša dithekniki goba ditaele tša go fapafapana tšeo di šomišitšwego ge go elwa mabokgoni goba tsebo. Mohlala, mabokgoni goba tsebo ya diteng tše dingwe e ka elwa ka go šomiša (dipotšišo tšeo barutwana ba kgethago karabo ya maleba go dikarabo tšeo di filwego, goba yeo ba kgomagantšhago mantšu, ba feleletše mafoko, dipaterone bj.bj) Ge barutiši le barutwana ba ka hwetša mehlala ya dipotšišo tšeo di botšišitšwego ka mekgwa ya go fapafapana, fela karabo e le ye tee, ba swanetše go kwešiša gore se se dirilwe ka boomo gomme barutwana ba swanetše go araba dipotšišo ka moka. Barutiši le barutwana ba swanetše go kwešiša gore se se diretšwe gore barutwana ba arabe dipotšišo tša mohlala wa lephephe. Go ba fa mekgwa ye e fapanego ya thekniki le setaele sa go botšiša dipotšišo go fa barutwana boitshepo bja go ngwala meleko/melekwana.

3. Kgokagano le didirišwa tše dingwe tša go rutwa le go ithuta.

Dipotšišo tše dingwe tša mohlala wa lephephe di kgokagantšhitšwe ka boomo le dipuku tša barutwana tša go šoma, go lebeletšwe mphato wo o itšeng wa maleba, e le go leka go hlagiša tswalano le kamano ya maleba.

Mehlala ya lephephe e beakantšwe go lebeletšwe dinyakwa tša go tšweletšwa ka gare ga Setatementsa Sa Kharikhulamo ya Bosetšhaba Mphato wa R - 12, Setatementsa sa Pholisi sa Lenaneothuto le Kelo Mphato wa R – 3, le Setatementsa sa Protokholo le Kelo ya Bosetšhaba.

Ditokomane tše ka moka, gommogo tše dingwe tšeo dikolo di ka bago le tšona di bopa pankwa ya maleba ya go nona ya didirišwa, go thuša barutiši ka peakanyo ya dithuto tša letšatši ka letšatši le mokgwa wa go hlama le go ngwadiša barutwana Kelo ya semmušo. (Kelo ya go ithuta).

4. Naa mehlala ye ya maphephe e ka šomišwa bjang?

Ge mehlala ya maphephe a mphato wo o itšego le thuto di kgobakantšhitšwe go sehlopha se tee, morutiši ga a swanela go fa barutwana gore ba arabe ka nako ye tee. Morutiši o swanetše go kgetha mehlala ya dipotšišo tšeo di lebanego le thuto yeo e beakantšwego ka nako ye e abilwego. Ka hlokomelo kgetha dipotšišo tše itšego go tšwa go mehlala ya maphephe a dipotšišo goba sehlopha sa dipotšišo tšeo di laolegago di ka šomišwa magatong a go fapana a go ruta le go ithuta ka tsela ye e latelago.

Morutiši a ka šomiša ditselana tše:

- 4.1. Mathomong a thutwana bjalo ka teko ya **diagnostiki** go tseba bokgoni le mafokodi a barutwana. Diagnostiki e swanetše go fa barutwana dipolelo tša bokgoni le mafokodi a bona, le go thuša morutiši go hlama dithutwana tša maleba tšeo di laetšago mafokodi le go kgohlagantšha bokgoni. Teko ye ya diagnostiki e ka fiwa barutwana bjalo ka mošomo wa gae go boloka nako ya go fa ditaelo ka phapošing.
- 4.2. Nakong ya go ruta teko ya **formatife** e fiwa barutwana go lekodišiša ge barutwana ba tšweletša bokgoni le tsebo yeo e letetšwego ge thutwana e rutwa go ya pele, le go hlokomela gore ga go morutwana yoo a šalelago morago.
- 4.3. Mafelelong a thuto goba dithutwana tše dintši tša go fapana, bjalo ka teko ya **sammative** e fiwa barutwana go lekodišiša ge barutwana ba hweditše kwešišo gomme ba kgona go bontšha bokgoni le tsebo yeo ba ithutilego. Barutwana ba swanetše go hwetša dipolelo tša bona gomme morutiši a bone gore naa barutwana ba hloka thušo ka dikarabo dife tša thutwana.
- 4.4. Magatong ka moka barutwana ba swanetše ke go lekolwa go ya ka dithekniki tša go fapana tša mehuta ka moka ya dipotšišo, bjalo ka go kgetha karabo ya maleba, go tlatša karabo sekgobeng seo a se filwego, go fa karabo ka lentšu, bj.bj. Ge diteko tša **diagnostiki** le **formatife** di ka ba tše kopana go ya ka palo ya dipotšišo tše di filwego, fela ya **sammative** e tla akaretša dipotšišo tše dintši go lebeletšwe dithuto tšeo di rutilwego ka nako yeo. Taba ya bohlokwa ke gore barutwana ba hwetše nako ya go ithuta go araba dipotšišo tša moleko wa go swana le ANA.

5. Memorantamo le ditšhupatsela tša go araba dipotšišo.

Mohlala wa dikarabo tša go fapafapana tšeo di letetšwego di laeditšwe mo go memorantamo. Barutiši ba swanetše go gopola gore memorantamo wo o ka se ke wa ba lapiša ka ge el le wa maleba. Maikemišetšo a memorantamo wo ke gofa barutiši tlhahlo e botse ya mokgwa wo barutwana ba ka fago dikarabo tša go fapafapana ka gona. Barutiši ba swanetše go tsenelela le go fa moputso ka mokgwa wa go amogelega le go putsa dikarabo tša go fapana go ya ka kwešišo ya barutwana.

6. Phethagatšo ya kharikhulamo.

Go bohlokwa kudu gore kharikhulamo e swanetše go phethagatšwa ka moka mphatong wo mongwe le wo mongwe. Mehlala ya maphephe ya mphato ka moka le thuto ga di emele kharikhulamo ka moka, fela di laetša tsebo le bokgoni bjoo bana ba ka bo laetšago kotareng ya 1, 2 le 3 ka ngwaga. Mošomo

wo barutwana ba swanetšego go o rutwa o laeditšwe ka gare ga Setatemente sa Pholisi sa Lenaneothuto le Kelo (SEPHOLEKE/CAPS).

7. Mafetšo

Maikemišetšo a Lefapa la Thuto ke go tšwetša kgatelopele ya magato le boleng bja bokgoni bja barutwana go mabokgoni a maleme le dipalo. Lefapa la thuto le šomiša ANA bjalo ka sedirišwa sa go lekola ge e le gore bokgoni bja barutwana bo a hlatloga, bo eme felo go tee goba bo a theoga. Dilete le dikolo di swanetše go fa barutiši thekgo le go didirišwa tšeo di hlokegago go dira gore thuto le go rutwa di hlatloge. Ka go šomiša mehlala ya maphephe a ANA bjalo ka didirišwa tšeo di tla thušago barutwana go ba le tsebo ya mekgwanakgwana yeo dipotšišo di ka botšišwago ka gona. Ge mehlala ya maphephe e ka dirišwa gabotse e ka thuša barutwana goba le tsebo le mabokgoni a go ithuta ao a okeditšwego ka mokgwa wa maleba gomme ba šoma gabotse dithutong tša bona le molekong wa ANA wo o tlogo

DINOMORO, DIOPHAREIŠENE LE DITSWALANO.

1. Tlatša dinomoro tšeo di tlogetšwego dikgobeng tšeo o di filwego.

(a) 350; 450; _____ ; 650; _____ ; _____ ; 950

(b) 500; _____ ; 498; 497; _____ ; _____ ; 494

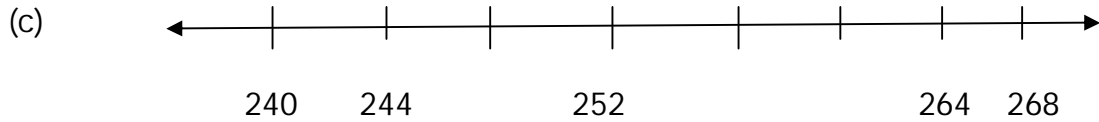

2. Feleletša tafola ye.

a.	50					300		400					650		
b.		1 2 6	129				141								165
c.	498					488				478			472		
d.	205				225					250		260			
e.		3 1 2		310	309				305						299

3. Latelela mesebe gomme o ngwale dinomoro tšeo di tlogetšwego ka mapokising.

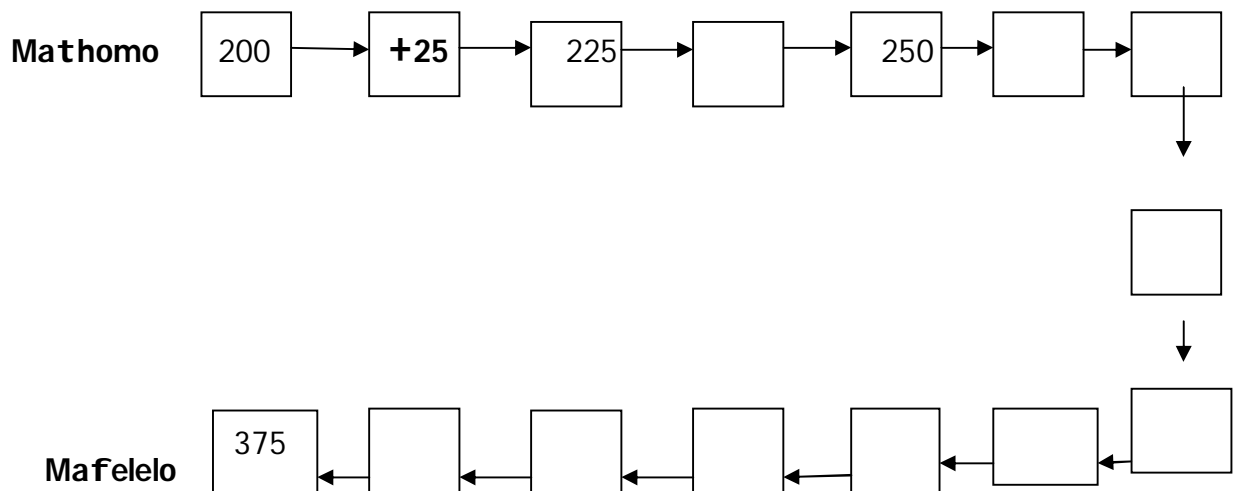

4.



Suzan o šoma femeng ya dikerese. O paka dikerese tše 10 ka gare ga lepokisi.

Nomoro ya dikerese yeo e pakilwego ka gare ga mapokisi a 15 =

5.

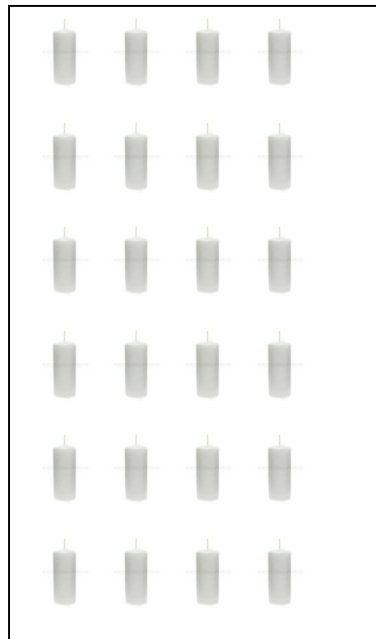

(a) Naa ke dikerese tše kae mothalading o tee wa go putla?

(b) Palomoka ya dikerese mo seswantšhong = _____

6. Ngwala dinomoro tše ka mantšu.

(a) 473 _____

(b) 204 _____

7. Ngwala nomoro yeo e tlogo magareng ga 268 le 270 ka nomoro palo.

(a) Nomoro palo _____.

(b) Nomoro ka mantšu _____ .

8. Ngwala nomoro 780 ka mantšu _____ .

9. Thala mothalo go lebantšha nomoro le leina la nomoro.

Makgolotharo masometshela tee	160
Makgolopedi lesome	483
Makgolotharo lesometshela	361
Lekgolo masometshela	316
Makgolonne masomeseswai tharo	210

10. Ngwala dinomoro tše ka tatelano go tloga ka ye nnyane.

13 31 28 6 2

11.

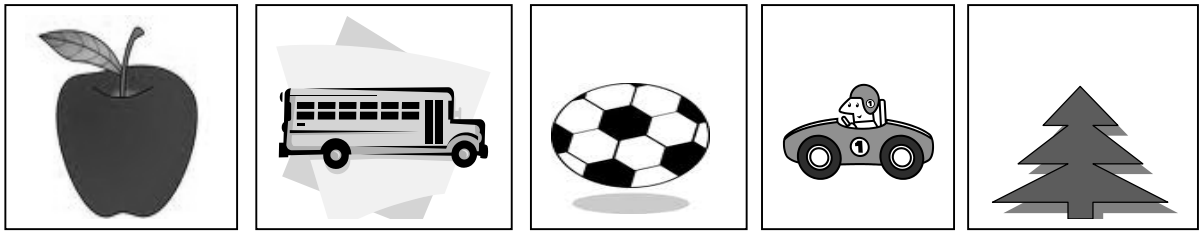

Lebelela diswantšho tše. Naa koloi e ka lepokisaneng la bo kae go tloga ka letsogong la ngele?

Koloi e ka lepokising la bo _____ go tšwa ka letsogong la ngele.

12. Tlatša > le < go dira palofoko ye nnete.

(a) 613 _____ 731

(b) 490 _____ 290

(c) 327 _____ 732

13. Dikološa tlhaka ya karabo ya nnete.

A 472 > 742

B 399 < 500 + 99

C 221 = 122

D 749 > 750 - 1

14. Beakanya dinomoro tše go tloga go **ye nnyane** go fihla go **ye kgolo**

(a) 631 , 366 , 613 , 376 , 276 , 167

(b) 742 , 422 , 472 , 727 , 442 , 247

15. Tlatša ka nomoro yeo e tlogetšwego.

(a) $673 = \underline{\hspace{2cm}} + 3$

(b) $417 = 410 + \underline{\hspace{2cm}}$

16. Ngwala boleng bj a nomoro yeo e thaletšwego.

(a) $4\underline{7}2$

(b) $2\underline{7}$

17. Mo go nomoro 694 go na le masome a 69. Naa ke nnete goba maaka?

18. Thalela karabo yeo e nepagetšego.

Mo go nomoro ye 374, 3 e maemong a .

(a) masome

(b) makgolo

(c) metšo

19. Ripaganya 573 ka tsela tše pedi tša go fapana .

$573 = \underline{\hspace{4cm}}$

$573 = \underline{\hspace{4cm}}$

20. Ngwala nomoro goba mantšu ao a tlogetšwego ka gare ga mapokisi.

(a) $298 = \boxed{\hspace{1cm}} \text{ makgolo} + \boxed{\hspace{1cm}} \text{ masome} + \text{metšo } \boxed{\hspace{1cm}}$

(b) $310 = 3 \boxed{\hspace{2cm}} + 1 \boxed{\hspace{2cm}} 0 \boxed{\hspace{2cm}}$

21. Lebantšha nomoro le dikarata tša maleba.

316
128
411
269

400	1	10
200	60	9
10	300	6
8	20	100

22. Ngwala $10 + 7 + 300$ ka mokgwa wo mokopana.

23. Tlatša ka dinomoro tšeo di tlogetšwego.

	Oketša nomoro gabedi	Nomoro	Seripa sa nomoro
(a)		150	
(b)		84	
(c)		21	

24. Ngwala 352 maemong a nnete mo mothalopalong.

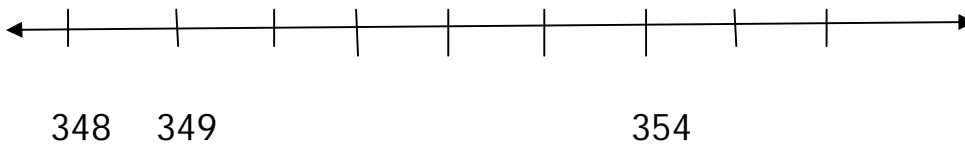

25. Batametša dinomoro tše kgauswi le lesome(10).

(a) $62 = \underline{\hspace{2cm}}$

(b) $127 = \underline{\hspace{2cm}}$

26. Morutiši o laetše barutwana gore ba kgoboketše dikhurumelo tša mabotlelo mo mafelelong a beke. Sassy o kgobokeditše dikhurumelo tše 619 gomme Lebo tše 125. Naa Sassy le Lebo ba kgobokeditše dikhurumelo tša mabotlelo tše kae ge di hlakane?
27. Anna le bagwera ba gagwe ba 3 ba kgoboketša ditempe go bapala papadi ka tšona. O mongwe le o mongwe o kgobokeditše ditempe tše 23. Naa ba kgobokeditše ditempe tše kae ka moka ge di hlakane?
28. Morutiši o tlile le dibisikiti tše 45 sekolong. O nyaka go abela barutwana ba 4 bao ba fihlilego sekolong ka nako dibisikiti tšeo ka go lekana. Naa morutwana o mongwe le o mongwe o tla hwetša dibisikiti tše kae?
29. Abela Themba le mogwera wa gagwe memabolo e 68 ka go lekana. Naa o mongwe le o mongwe o tla hwetša memabolo e me kae?
30. Bagwera ba bararo ba rekile malekere a 35 gomme ba abelana ka go lekana. Naa o mongwe le o mongwe o tla hwetša malekere a makae?
31. Busi o na le memabolo e 125. O fetišwa ke Vera ka memabolo e me kae?
32. Mo boemong bj a dikoloi lebenkeleng la Shoprite go na le dikoloi tše 21. Naa ke maotwana a ma kae ka moka ge a hlakane re bala le maotwana a go otlela?

33. Šomiša lenaneo la ditheko go araba dipotšišo tše.

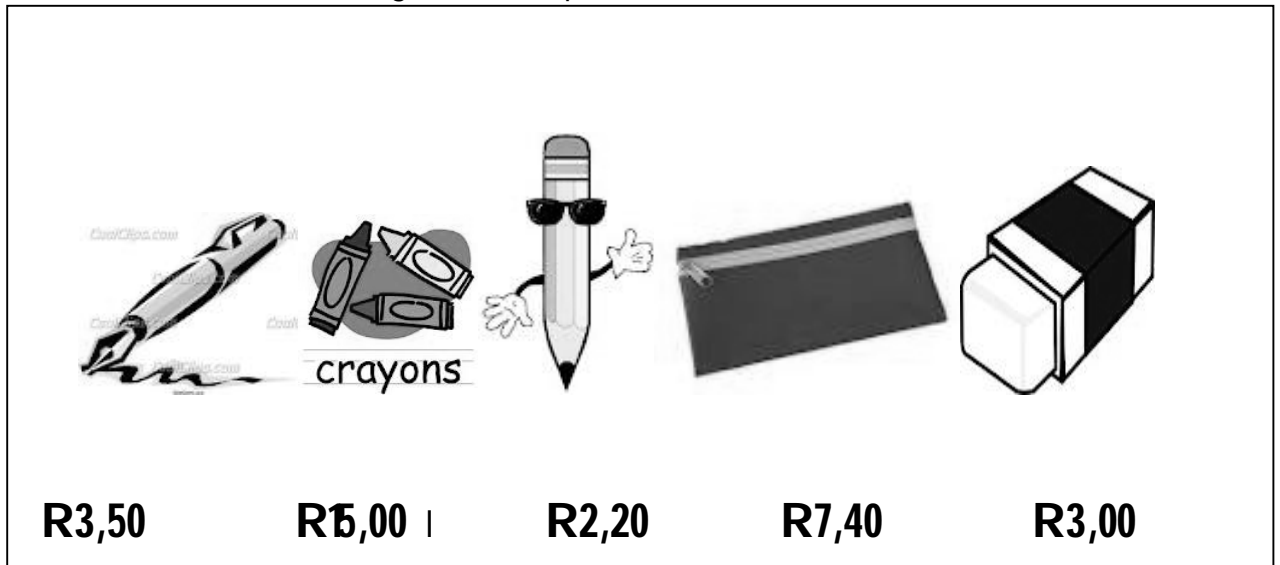

(a) Naa phapano ke eng magareng ga theko ya pene le theko ya phensele?

(b) Sanie o rekile dipene tše 2, phensele, raba le sekhwama sa diphensele. Naa šomišitše bo kae go reka dilo tše ka moka?

(c) Morutiši o nyaka go reka mapokisi a 2 a dikherayone, dipene tše 2 le diphensele tše 2. Balela tšhentšhi ya gagwe ge a patetše ka R50.

(d) Naa Mosa o rekile mapokisi a ma kae a dikherayone ge a patetše R60 go reka?

34 Feleletša:

(a) $763c = R$ _____

(b) $207c = R$ _____

(c) $579c = R$ _____

(d) $R2,63 =$ _____



(e) $R6,15 =$ _____ c

(f) $R4,25 =$ _____

DIPATERONE, DIFANKŠENE LE ALTŠEBRA

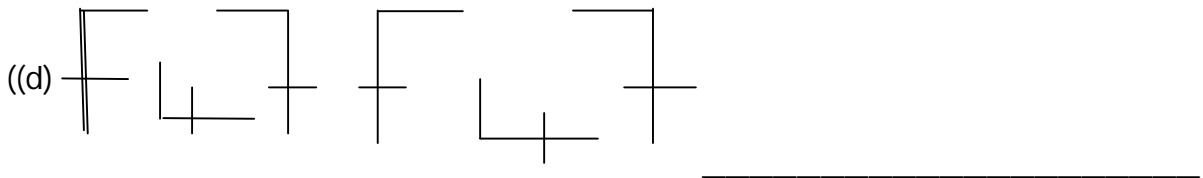
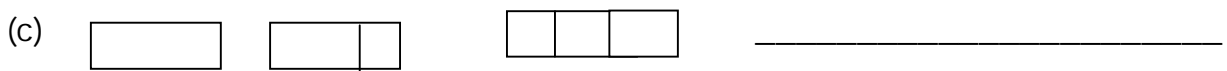
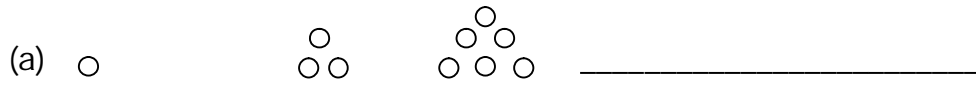
1. Thala sebopego sa go latela go feleletša paterone.



2. Šomiša dibopego tše    go bopa paterone ya gago.
Boeletša paterone ga 3.

3. (a) Ngwala dinomoro tše 3 tša go latela.

526, 527, 528, _____ , _____ , _____

Hlaloša paterone ka mantšu a gago.

(b) Tlaleletša dinomoro tše di tlogetšwego.

738, 736, 734, _____ , _____ , _____ , 726

Hlaloša paterone ka mantšu a gago.

4. Rakgolo Malope o nyaka go paka dikotikoti tša senwamaphodi ka gare ga makase. Lekase le tee le swara dikotikoti tše 25 tša senwamaphodi. Feleletša tafola ye.

Nomoro ya makase	1	2	3	4		6
Nomoro ya dikotikoti	25	50		100	125	

5. Thoma ka nomoro yeo o e filwego go ngwala paterone ya gago. Hlaloša gore o šomišitše molawana ofe.

(a) 330, _____ , _____ , _____ .
Molawana _____

(b) 504 , _____ , _____ , _____ , _____
molawana : _____

1. **SEKGOBA LE SEBOPEGO**

Dikološa tlhaka ya karabo yeo e nepagetšego.

Naa khone ke efe mo go dilo tše?

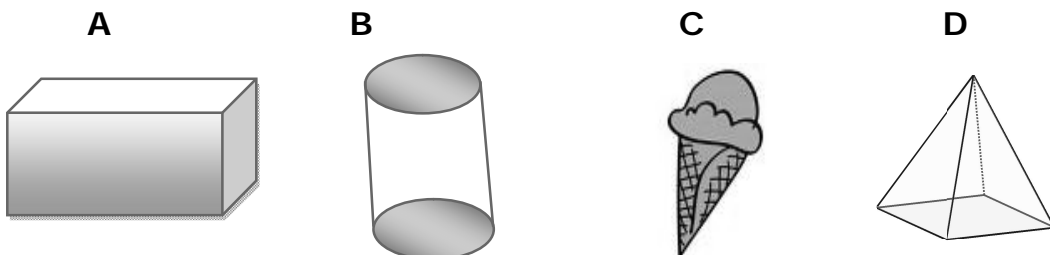

2. Dikološa tlhaka ya karabo yeo e nepagetšego.
Naa ke sebopego sefe sa 2-D seo se ka šomišwago go dira phiramiti ya bo fase bj a khutlonnethwii?

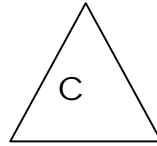
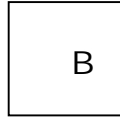
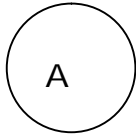

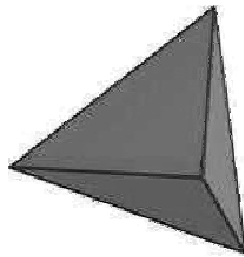

3. Lekodišiša seswantšho se gomme o arabe dipotšišo tše latelago.

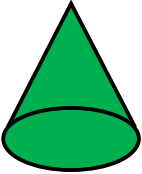

- a. Naa leina la selo se sa 3-D ke eng? _____
- b. Naa selo se sa 3-D se na le difahlego tše kae? _____

2. Thala mothalo go lebantšha sebopego le leina la sona.

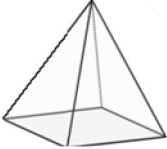
	<p>phiramiti ya bo fase bja khutlonnethwii</p>
	<p>khone</p>
	<p>Phorisime ya khutlonne</p>
	<p>Silintara</p>

1. KELO

Naa o tla šomiša eng go ela

- (a) Botelele bj a puku? _____
- (b) Bophara bj a phapoši? _____

2. I thute khalentara ye gomme o arabe dipotšišo tše di latelago.



(a) Naa dikgwedi tša go ba le matsatši a 30 ke tše kae? _____

(b) Ngwaga wa tlwaelo o na le matsatši a = _____

(c) Kgwedi ya July e na le matsatši a = _____

(d) Ngwaga o na le dibeke tše = _____

(e) Ngwaga o na le dikgwedi tše = _____

(f) Palo ya matsatši gare ga Letšatši la Bašomi le Letšatši la Baswa = _____

3. Šomiša khalentara ya potšišo 2 go tlatša tafola ye.

Letšatšikgwedi		Matšatši a go khutša a Afrika Borwa	Letšatši la beke mo khalentareng
(a)	01 January 2012	Letšatši la Ngwaga o mofswa	
(b)	21 March 2012	Letšatši la Ditokelo tša Botho	
(c)	01 May 2012	Letšatši la Bašomi	
(d)	16 June 2012	Letšatši la Baswa	

4. Matšatši a 42 a lekana le dibeke tše _____

5. Dikgwedi tše 4 di lekana le _____ ya ngwaga.

6. Feleletša: Ge lenakana le le nnyane la sešupanako le šupile go 10,
le bontšha _____ le _____

7. Thoma ka go akanya ge o feditše o šomiše rula go ela botelele bj a lehlakore le lengwe le le lengwe ka disentimetara go diswantšho tše dilatelago. Ngwala dikarabo tafoleng ya ka fase.

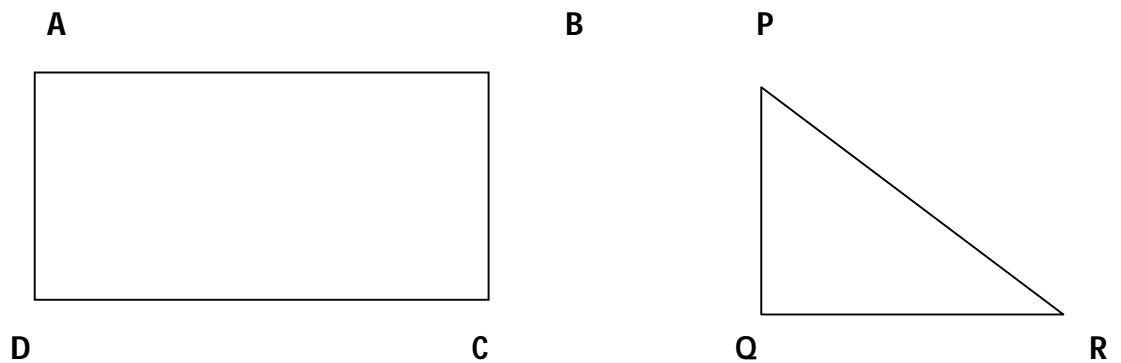

	Mahlakore	Kakanyo	Kelo ya maleba
(a)	AB		
(b)	BC		
(c)	DC		
(d)	AD		
(e)	PQ		
(f)	PR		
(g)	QR		

8. Hlakantšha palomoka ya sekgoba gare ga diboego go potšišo 6.

(a) sekgoba sa khutlonne ABCD, =

(b) sekgoba sa khutlotharo PQR, =

Tšhomišo ya Data.

1. Sammy o ngwadile bogolo bj a dieta tša barutwana bao a tsenago le bona ka mphatong o tee ka tsela e:

4 7 7 6 4 5 3 6 7

4 5 3 3 6 7 3 3 5

7 4 6 5 3 4

6 3 4 4 7 4 3 5

Palo ya barutwana bao ba aparago dieta tša bogolo bj a

3 = _____

4 = _____

5 = _____

6 = _____

7 = _____

Thala para kerafo go laetša tshedimošo e.

2. Lekodišiša para kerafo ye gomme o arabe dipotšišo tše.

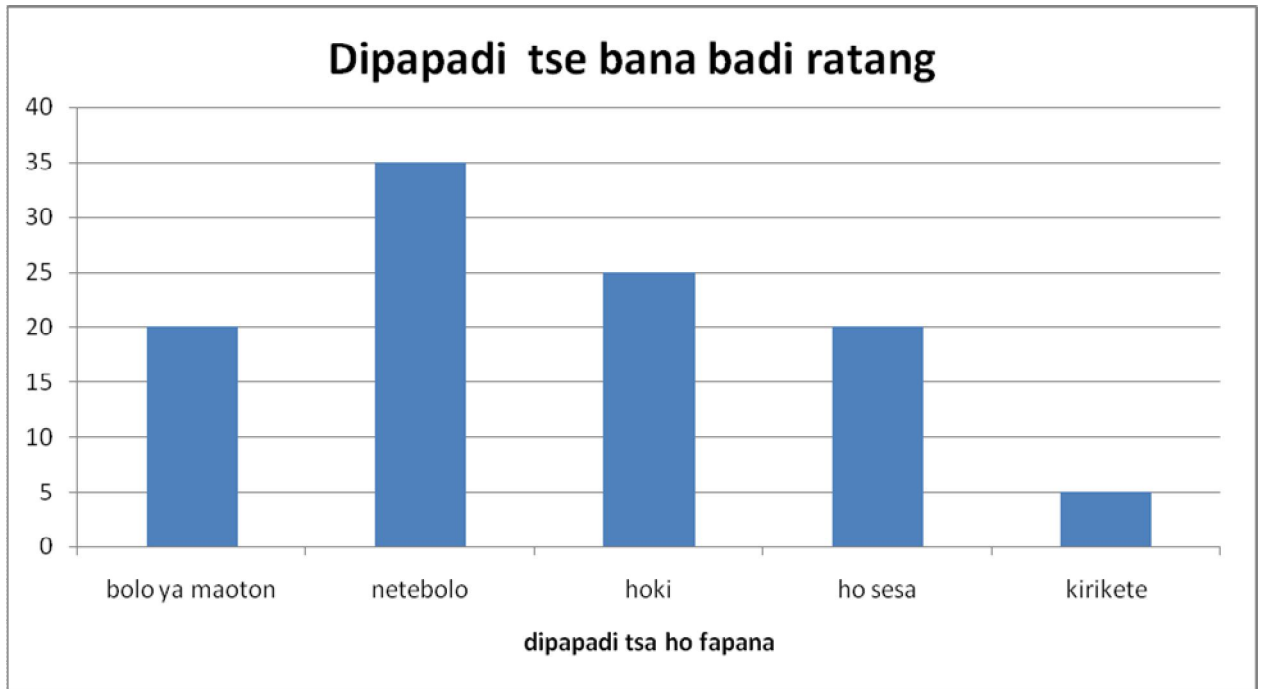

- (a) Naa ke barutwana ba ba kae bao ba ratago hoki? _____ .
- (b) Palo ya barutwana bao ba ratago kirikete ke _____.
- (c) Papadi yeo e ratwago ke barutwana ba ba ntši ke _____.
- (d) Papadi yeo e ratwago ke barutwana ba ba nnyane ke _____.
- (e) Ke dipapadi dife tše 2 tšeo di ratago ke palo ya go lekana ya barutwana? _____ .

3. Para kerafo ye e bontšha palo ya dinwamaphodi tšeo di rekišitšwego ka lebenkeleng la Siphon mo b

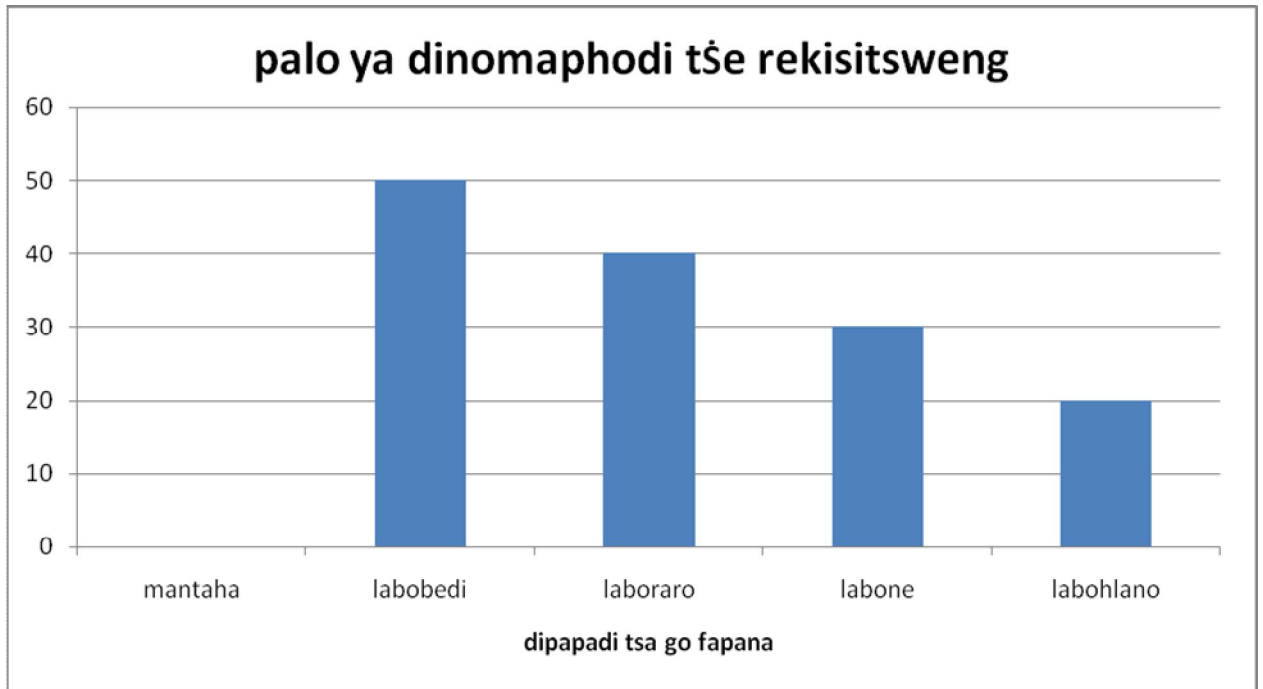

(a) Palo ya dinwamaphodi tšeo di rekišitšwego ka Monday ke =

(b) Letšatši leo ka lona go rekišitšwego dinwamaphodi tše dintši ke

(c) Palo ya dinwamaphodi tšeo di rekišitšwego ka Friday ke =

(d) Naa ke dinwamaphodi tše kae tšeo di rekišitšwego ka Friday

go feta ka Thursday?
