



basic education

Department:
Basic Education
REPUBLIC OF SOUTH AFRICA

**NATIONALE
SENIOR SERTIFIKAAT**

GRAAD 12

INGENIEURSGRAFIKA EN -ONTWERP V1

NOVEMBER 2012

MEMORANDUM

PUNTE: 100

Hierdie memorandum bestaan uit 7 bladsye.

ANTWOORDE

1	DESIGN FOR LIVING ARCHITECTS	1
2	LEBO	1
3	18/10/2012	1
4	DBE-2012-01	1
5	BEVESTIG ALLE AFMETINGS EN HOOGTES	1
6	1,8 m of 1 800 mm	1
7	1	1
8	16	1
9	OP (TRAP)	1
10	SEPTIESE TENK	1
11	RIOOLPYP/-LYN	1
12	ASFALT	1
13	RIGTING VAN OPENING VAN HEK	2
14	ONTSPANNINGSONTWIKKELING	2
15	128,55 m	2
16	INSPEKSIEOOG	1
17	21 880 mm	2
18	437,853 m [berekening 1, antwoord 1, meter 1]	3
19	1 214 m ² [berekening 1, antwoord 1, meter ² 1]	3
20		3

TOTAAL: 30

20

VRYHAND ✓

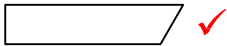



VRAESTEL 1 VRAAG 2
 GRAAD 12
 NOVEMBER 2012
 MEMORANDUM

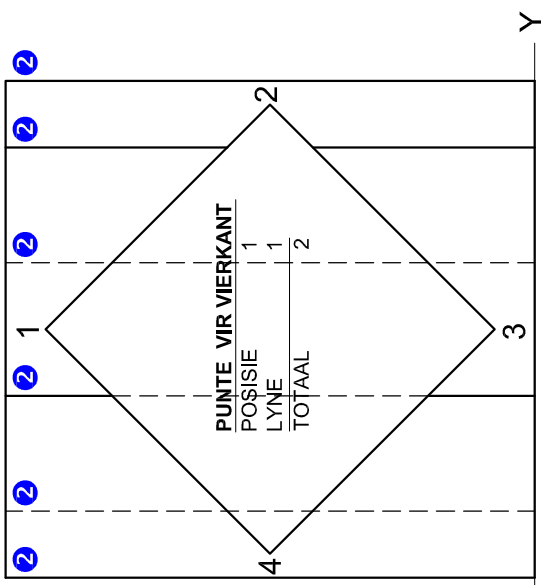
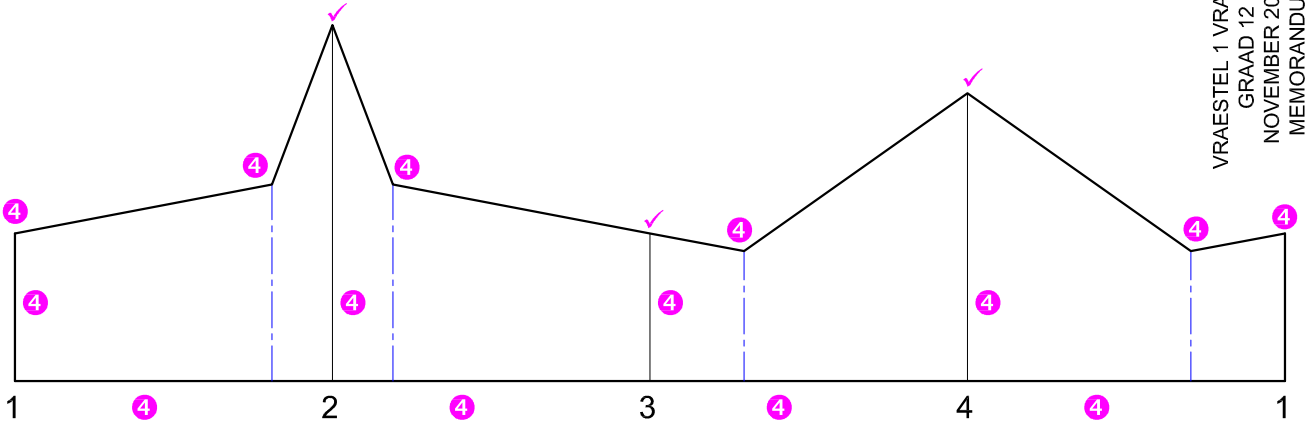

ASSESSERINGSKRITERIA	
1	BOAANSIG 6
2	LINKERAANSIG 5
3	VOORAANSIG 14
4	ONTWIKKELING 10
TOTAAL 35	

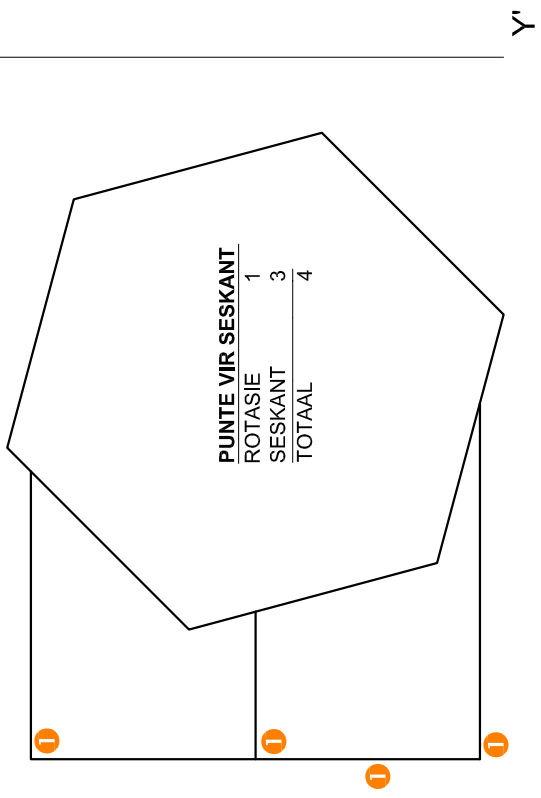
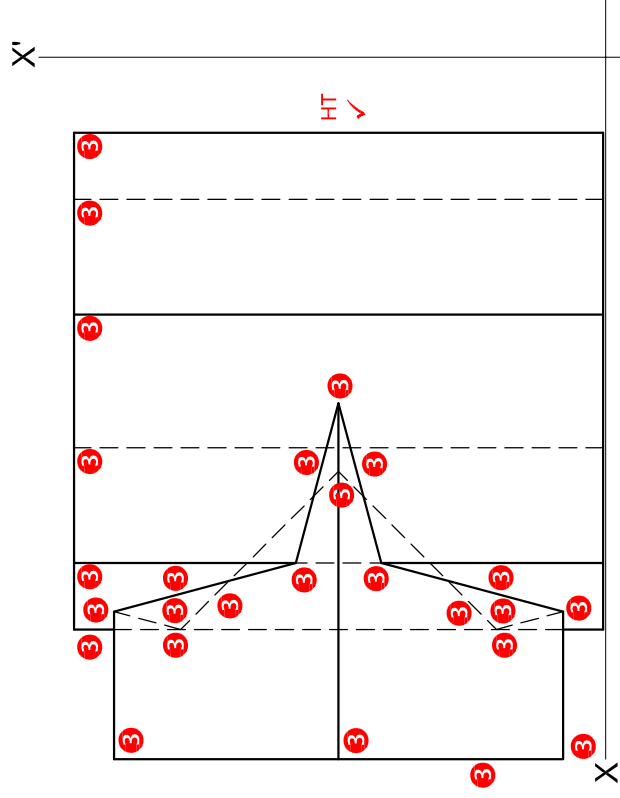

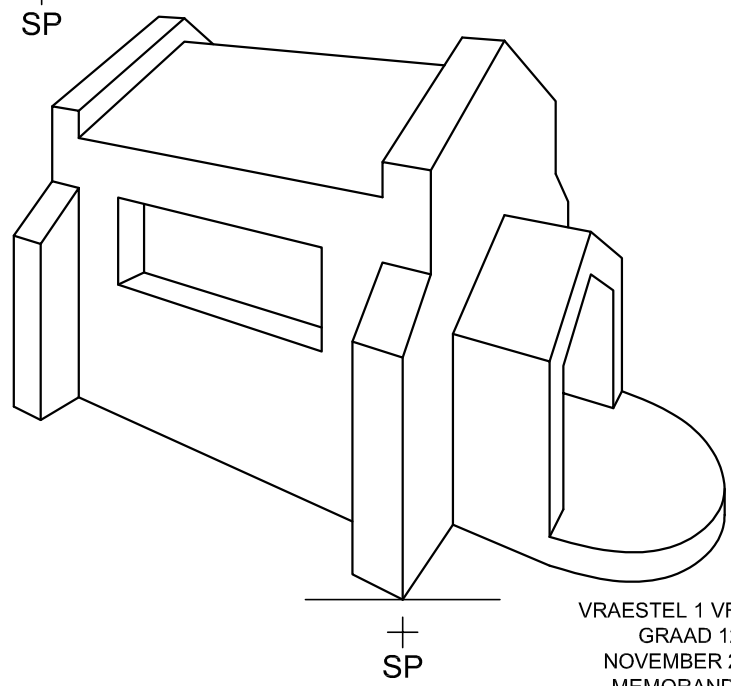
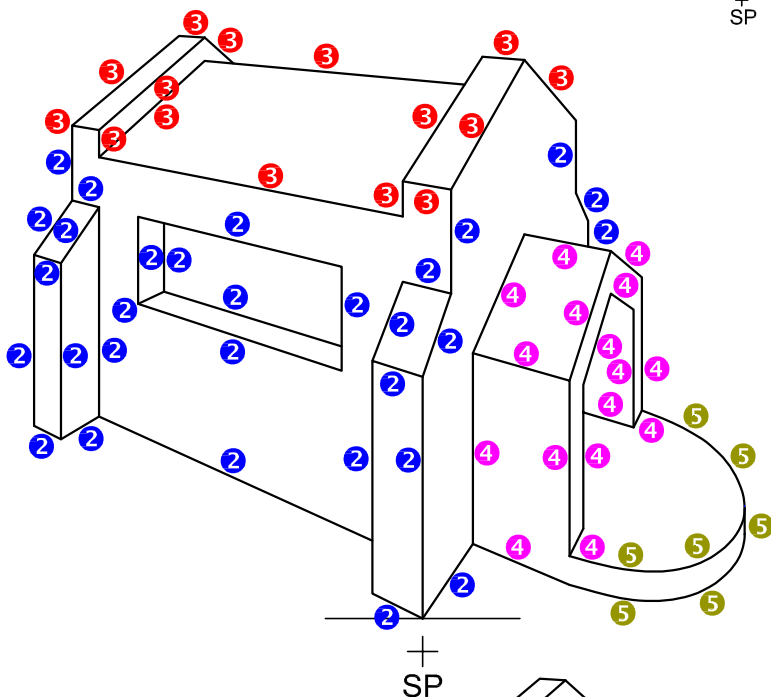
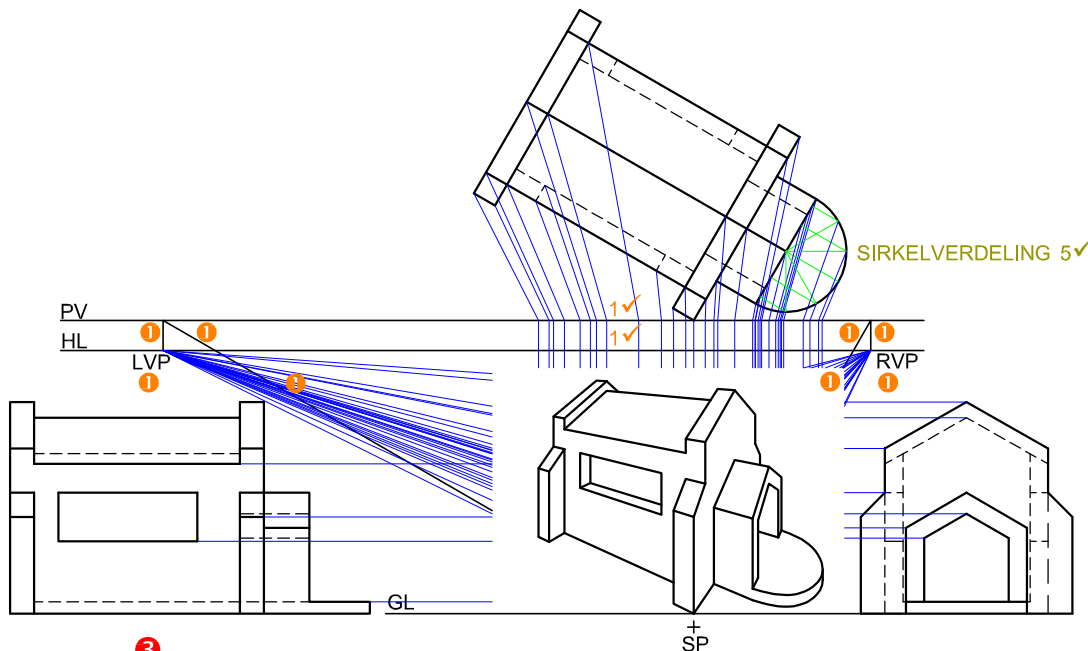

ASSESSERINGSKRITERIA		
1	KONSTRUKSIES + VP'e	6
2	GEBOU + VENSTER	15
3	DAK	7½
4	INGANG	8
5	HALFSIRKEL	4½
TOTAAL		41

VRAESTEL 1 VRAAG 3
GRAAD 12
NOVEMBER 2012
MEMORANDUM

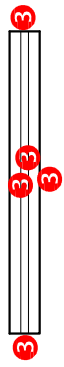
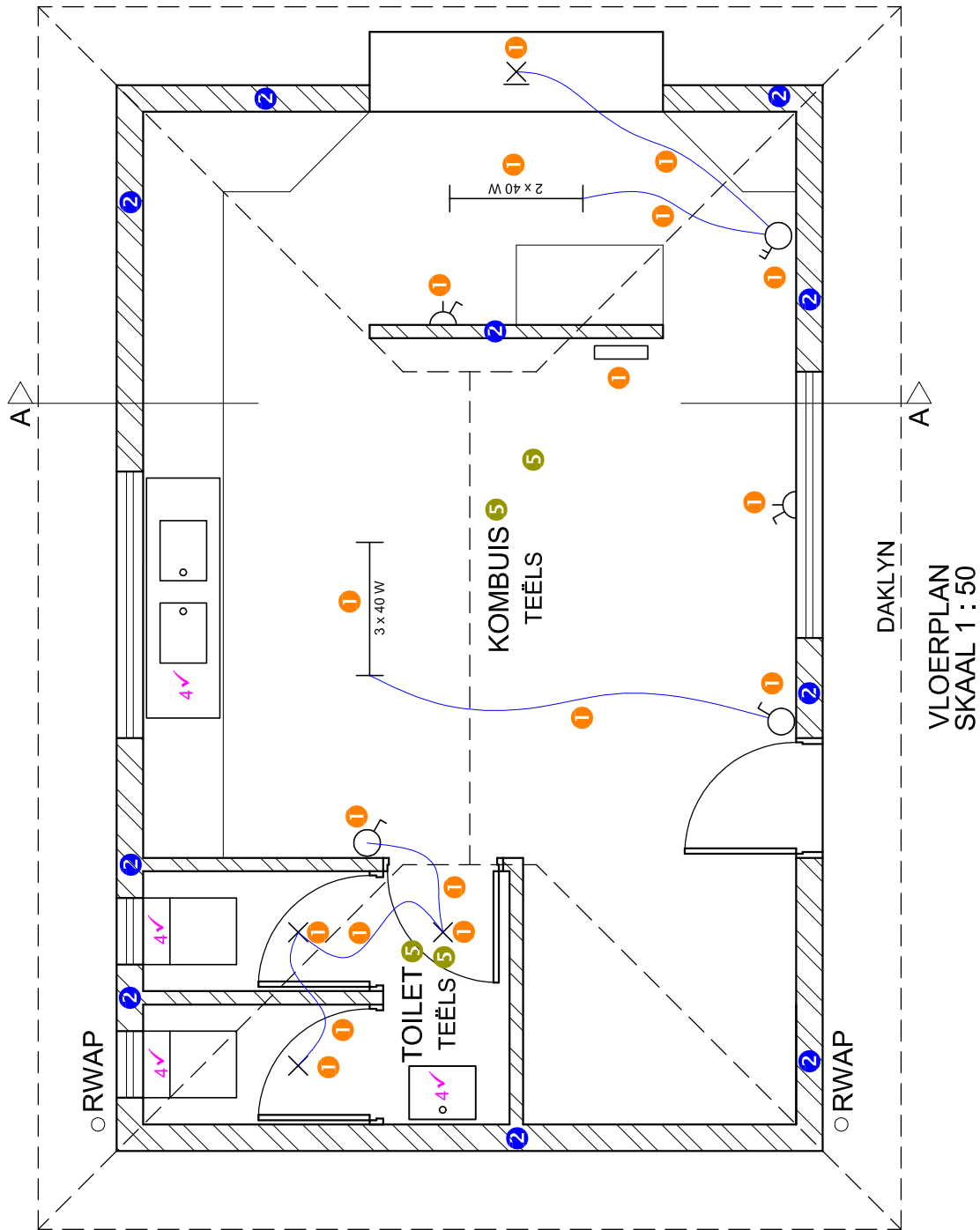

BESONDERHEDE VAN
PUNTTOEKENNING VIR 'N VENSTER
(2½ x 4 vensters = 10)

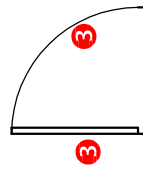

BESONDERHEDE VAN
PUNTTOEKENNING VIR 'N DEUR
(1 x 4 deure = 4)

VLOERPLAN	
1	ELEKTRIES 9
2	ARSERING 5
3	DEURE + VENSTERS 14
4	TOEBEHORE 4
5	BYSKRIFTE 2
SUBTOTAAL 34	

DAKLYN
VLOERPLAN
SKAAL 1 : 50

VRAESTEL 1 VRAAG 4
GRAAD 12
NOVEMBER 2012
MEMORANDUM

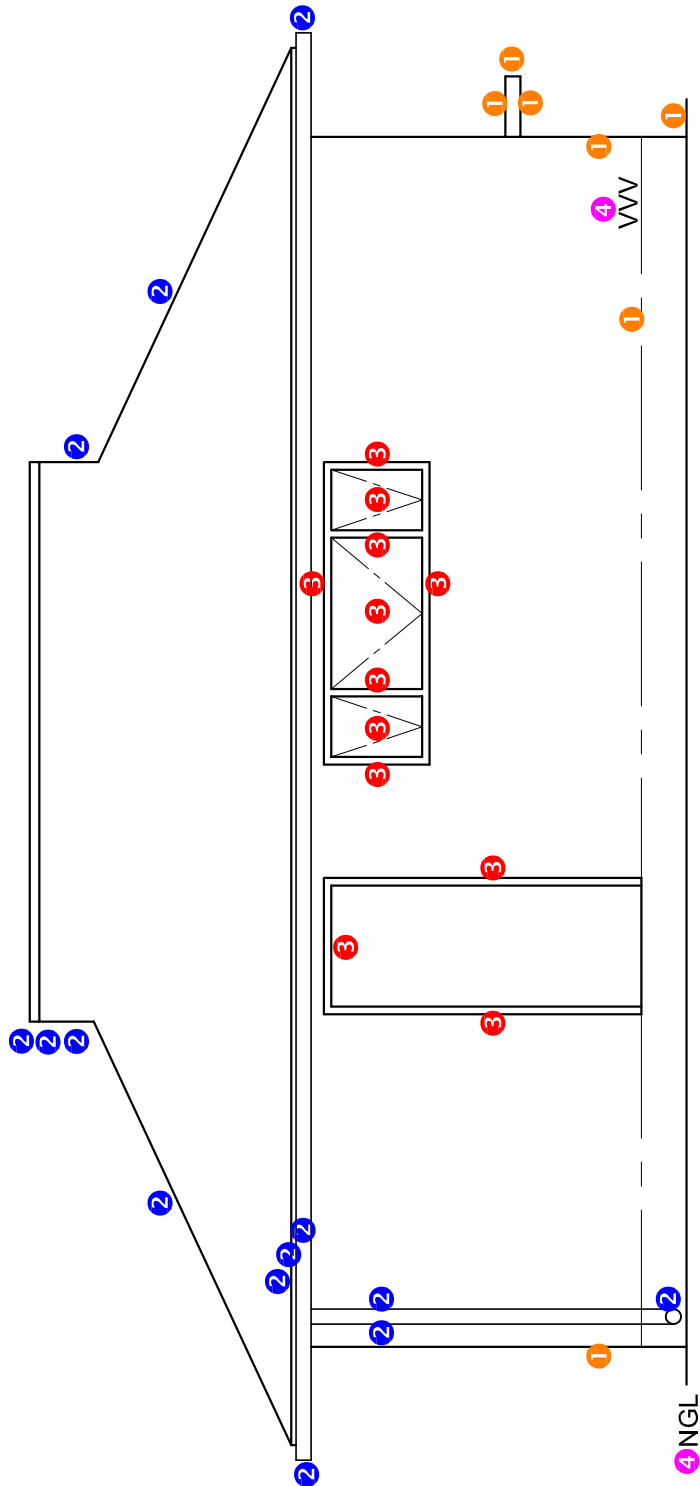

4 WESAANSIG

WESAANSIG		
1	MURE + VWV + DIENLUIK	3½
2	DAK + GEUT + RWAP	7
3	DEUR + VENSTER	6
4	BYSKRIFTE	1½
SUBTOTAAL		18

VRAESTEL 1 VRAAG 4
 GRAAD 12
 NOVEMBER 2012
 MEMORANDUM

- PUNTETOEKENNING**
- 1 DAKNOK
 - 2 DAKPLAAT
 - 2 DAKLATTE
 - 2 GEUTE
 - 1 MUURPLAAT (2 x 1/2)
 - 8 DAKKAP (7 x 1) + (2 x 1/2)
 - 1 PLAFONLATTE
 - 1 PLAFONBORD
 - TOTAAL 18

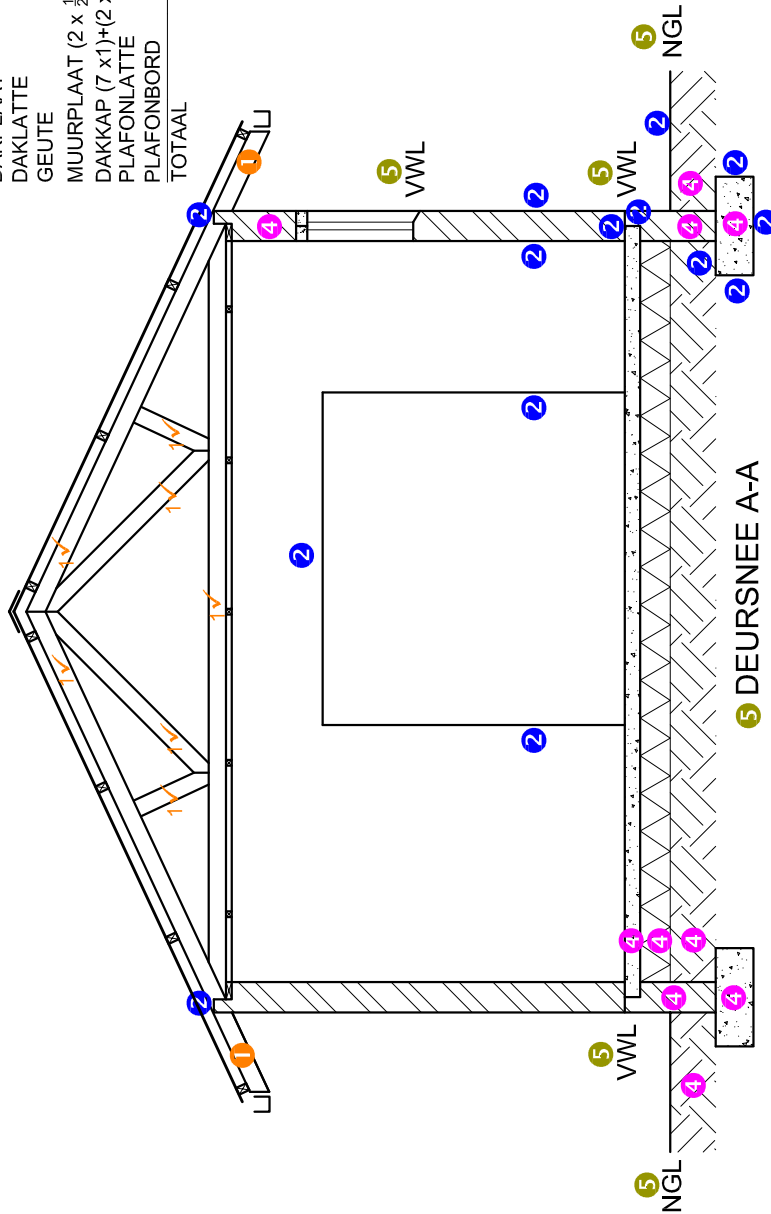

BESONDERHEDE VAN PUNTETOEKENNING VIR VENSTER

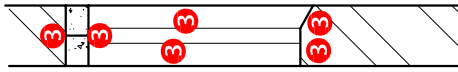

BESONDERHEDE VAN PUNTETOEKENNING VIR 'N LASDRAENDE MUUR

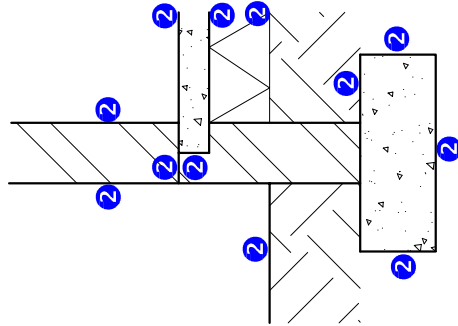

DEURSNEEAANSIG	
1	DAK + PLAFON 18
2	MURE + VLOER + FONDASIE 13
3	VENSTER 3
4	ARSERING 5
5	BYSKRIFTE 3
SUBTOTAAL 42	