

CONSUMER STUDIES Teacher Guide

CLOTHING OR SOFT FURNISHING

Consumer studies: Clothing / Soft Furnishing

Practical lessons – Grade 8

TERM 1
Week 1: Orientate the learners in the workplace room.
Week 2 & 3:
Practical Lesson 1: Personal Hygiene, Health & Safety Activity: Safety in the sewing room (Group work)
Week 4 – 6:
Activity: Basic sewing equipment Activity: Measuring equipment Activity: (Demonstration) Measuring Practical Lesson 2: Identification of Needlework equipment and tools Practical Lesson 3: Measuring equipment and tools
Week 7:
Activity: Basic Hand stitches for sewing and embroidery Activity: Basic Hand stitches for sewing and embroidery on an article
Week 8:
Practical Skills Test 1 Basic hand stitches for sewing and embroidery on swatches

TERM 2
Week 1:
Activity: Sewing machine
Activity: Function, threading, winding the bobbin
Week 2 & 3:
Practical Lesson 4: The Sewing Machine: parts, functions, thread, winding bobbin
Week 4 & 5:
Practical Lesson 5: The sewing licence
Week 6 & 7:
Practical Lesson 6: Commercial pattern
Activity: Sew seams on an article
Week 8:
Practical Skills Test 2 Evaluate a label for a product

TERM 3 Week 1: Activity: Enclosed single seam, shaped facing
Week 2 & 3: Practical Lesson 7: · Seams: The enclosed single seam on a sampler
Week 4 & 5: Activity: Seams on article / garment Practical Lesson 8: Hems sampler
Week 6 & 7: Apply hems on article Practical Lesson 9: Labelling Activity: Advertisement
Week 8: Practical Skills Test 3 Make an enclosed single seam on an article / garment

TERM 4 Week 1 - 3
Project based Learning Task <i>(Marketing and selling a product.)</i>

Grade 8 Term: 1

- **Hygiene, Safety and Security**
- **Introduction to the laboratory / workplace**

Introduction:

The environment in which you work influences your behaviour. To be truly productive, it is important to have a workplace where the furniture is well arranged. It must be arranged in such a way that activities can be performed with ease and with safety in mind. It's everyone's responsibility to keep the workplace and workstation clean and organized.

It is also important to wash your hands before touching your sewing fabrics and to wash them in-between working to prevent making your article dirty.



General safety rules in the Needlework class:

- Do not run in the class – you can be seriously hurt or damage appliances.
- Scissors are very dangerous, don't run or play with it.
- Be careful when working with irons or steam irons, you can burn if you do not handle them correctly.
- No learner is allowed to work without supervision in the needlework room.
- Report injuries immediately.
- Never touch blood if someone is injured, report immediately so the correct procedure can be followed.

- When helping someone that has a bleeding cut, always wear gloves so as to prevent HIV transmission.
- Make sure that there is a fire extinguisher in class and that it is in a working order.
- **Always concentrate on your own work.** While talking to a friend you may sew or cut something incorrectly.
- Avoid loose clothing or jewellery and tie up hair to prevent it from becoming tangled in the moving parts of the machine.

Basic safety rules for working with a sewing machine:

- Hold head up and out of the way of moving parts.
- Sit with back straight to help with concentration.
- Work should be done in a sitting position.

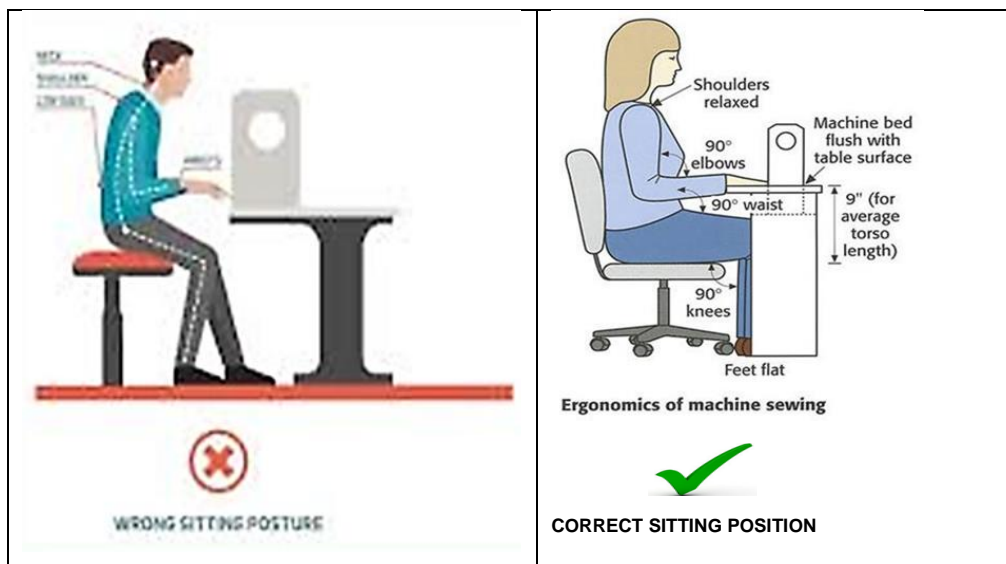

- Only use the sewing machine in the designated area in the classroom.
- Equipment and appliance should be arranged in such a way as to allow for safe movement.
- Keep your fingers away from the needle and moving parts of the sewing machine.
- Do not press the foot peddle on someone else's sewing machine.
- Electric cords must be out of the way as tripping over wires can cause injury and damage equipment.
- Switch current off before inserting or removing plugs from sockets.
- Switch off your sewing machine when making adjustments.

- Make sure you have good lighting while you are sewing.
- Make sure the machine is switched off and packed away when finished

Safety measures for working with electrical appliances, e.g. ironing equipment

- See that all three-pin plugs are connected correctly
- Examine old electric wires and flexes to see whether there are any broken places – repair immediately.
- First put plug in wall socket. Then switch the plug on. Do not ever switch the switch on first.
- Never pull out the plug by its cord. Take hold of the plug itself and remove it from the socket.
- Never use electrical appliance when you are barefoot.
- It is dangerous to use any electrical appliance close to water. Never touch anything electrical with wet hands or while standing in water.
- Never push metal objects or your fingers into a plug.
- Never overload a wall-socket. Do not plug in more than two appliances at the same time. Make use of appropriate adaptors





How to wire a plug?

Inside the plug there are three terminals:

Earth: Top, centre - this is where the green & yellow wire goes – however double insulated appliances do not have an earth wire

Live: The brown wire goes to the live terminal, which is on the right side of the plug.

Neutral: The blue wire connects to the blue terminal on the left of the plug.

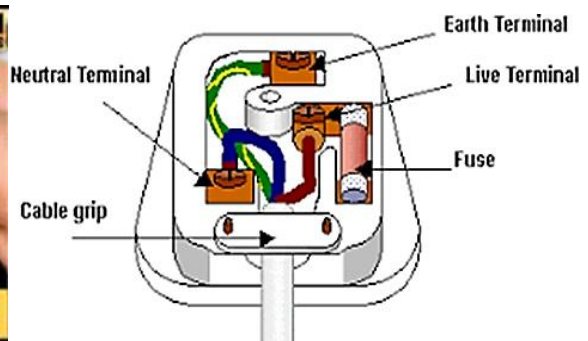

Fire Drill Safety Rules:

- Listen carefully to directions.
- Quietly line up
- Walk carefully out of the building to your assigned place.
- Stay with your class at all time.
- Wait with your teacher until it is safe to return to your classroom.

How to use the fire extinguisher

Remember the words **PASS**

- **P**ull the pin in the handle.
- **A**im the nozzle at the base of the fire.
- **S**queeze the lever slowly.

- Sweep from side to side

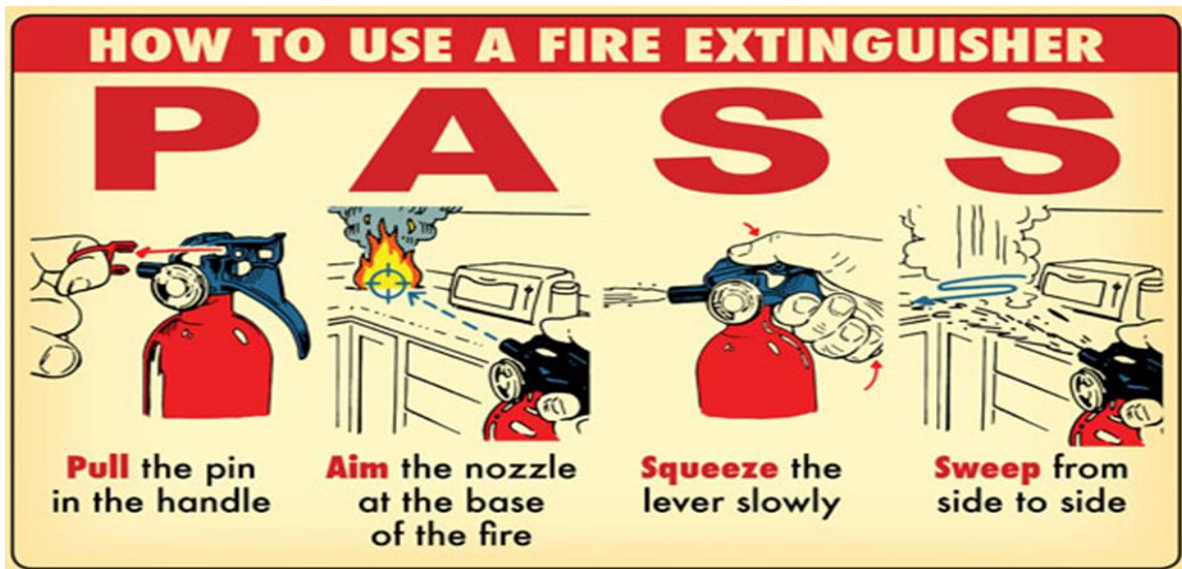

SAFETY SIGNS



BASIC FIRST AID

Always wash your hands. This helps to avoid infection.



Activity: Hand washing (Group work)

Learners do research about the steps in the hand washing procedure. Learners design and make an A-4 poster illustrating the steps in the hand washing procedure.

Poster: Handwashing

A large empty rectangular box provided for students to design their own handwashing poster.

Rinse the wound with clean water.
Wash out the wound with running water this
Will help reduce the risk of infection, or use a
disinfection wipe.



Remove any dirt with tweezers that is cleaned with
disinfectant.
See a doctor if you cannot remove all the dirt.



Stop any bleeding. Small cuts or scraps
usually stop bleeding on their own.
If needed apply gentle pressure with a
bandage or clean cloth.
If bleeding does not stop elevate the wound above the heart.



Apply an antibiotic or petroleum jelly. Apply a thin
ointment or Vaseline to keep surface moist and help
scarring.



layer of
prevent

Cover the wound with a bandage or
plaster, this also helps to keep the
wound clean.



Change the dressing often. At least once a day.



Get a tetanus injection if the wound is deep or dirty.

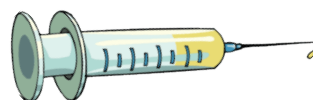

Watch for signs of infection. See a doctor if there is any signs around the wound that is red, increasing pain or swelling.



HIV/AIDS

HIV / AIDS is caused by the Human Immunodeficiency Virus (HIV).

When a person is now very ill because of the virus they have acquired immune deficiency syndrome

HIV is mainly transmitted through sexual intercourse, but can also be spread through open wounds and cuts.

Once a person is infected, the virus remains in the body for life.

There is no cure for HIV/AIDS, but there are drugs/medications that help to control the virus.



Avoid contact with blood

If you are helping a bleeding person:

- Avoid getting any of their blood into any sores or cuts that you may have on your skin.
- Also protect your eyes and your mouth.
- There should be gloves in all first aid kits – use them.
- If you pricked yourself or anyone else's finger and there is blood, discard the pin (throw in dustbin) and clean the wound.

CLASS ACTIVITY (Group work)

GRADE 8 TERM 1

Study the scenario below and create a poster about Hygiene, Health and Safety

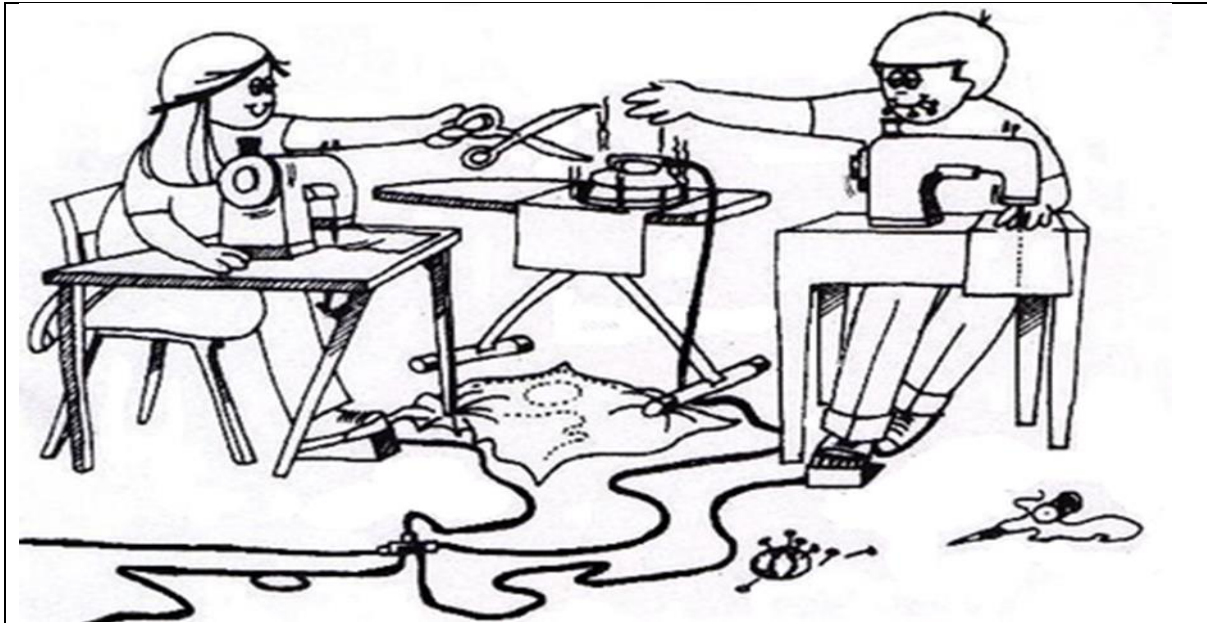

CLASS ACTIVITY	Marking guidelines	GRADE 8 TERM 1
-----------------------	---------------------------	-----------------------

Study the scenario below and create a poster about Hygiene, Health and Safety

Poster to incorporate FIVE of the following

Sitting position, overloading electrical points, handing of scissors, a tidy floor, electrical cords must not be damaged, hair tied back, switch off iron when not using it, furniture to be in good repair, using the correct equipment to keep pins (5)

Clearly presented poster (1)

Consumer Studies
Clothing or Soft Furnishing Option
Grade 8 Term 1
Practical lessons and Skills Tests

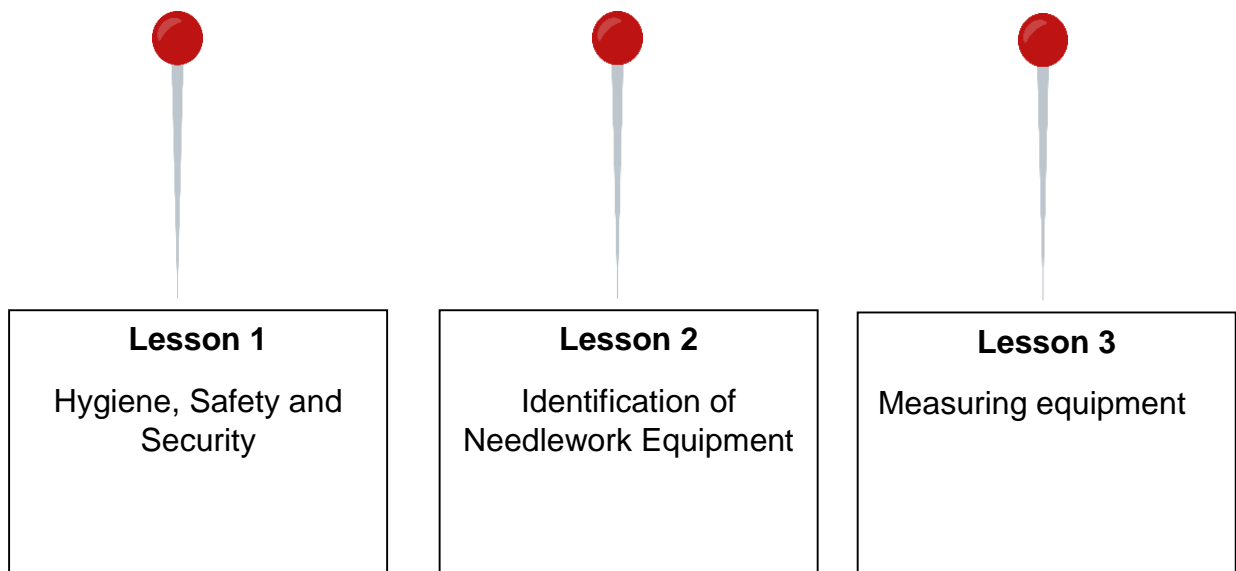
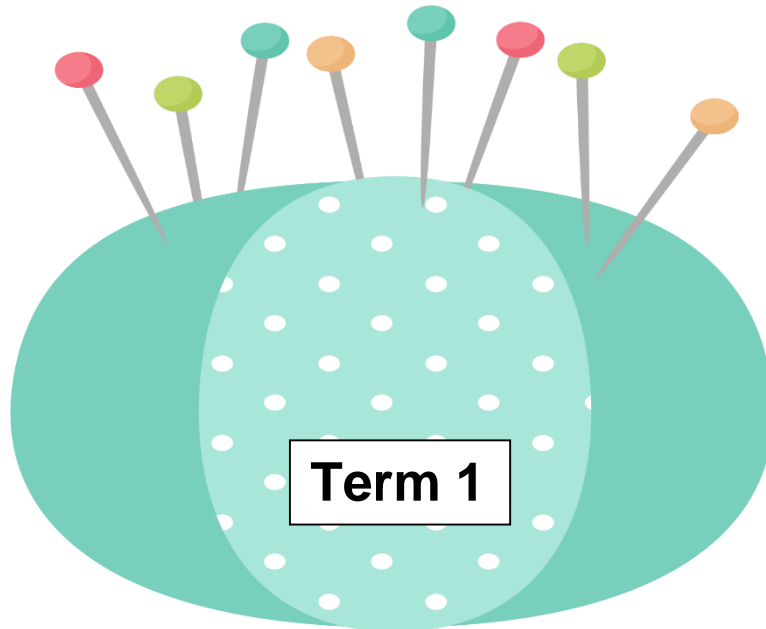

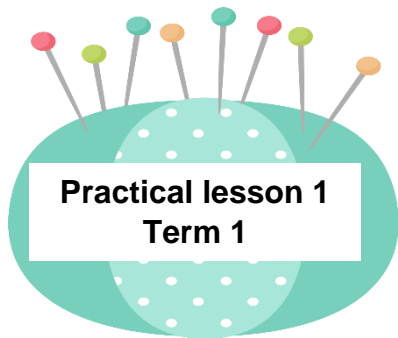

Consumer Studies

Module: Clothing production

Hygiene, Health, and Safety

Name:	Grade 8	
<p>1.1 Study the words below and reorganise them in the correct sequence/order when we are washing hands</p> <p>Rinse hands, apply soap, wet hands, dry hands, scrub hands</p>		
1.1		
(5)		
<p>2. Electricity can be very dangerous if we use it incorrectly. Describe the precautions you need to take when using electricity from the following scenarios.</p>		
2.1	You have wet hands:	
2.1		
2.2	Pulling the plug out of the wall:	
2.2		
2.3	You have 4 appliances:	
2.3		
2.4	You are walking barefooted:	
2.4		
2.5	You need to make adjustments on your electric sewing machine:	
2.5		
2.6	The electrical cord:	
2.6		

(6)

3. State what this sign means 	
3.	(1)
4. In the event of a fire, how will you operate the fire extinguisher? Name the FOUR steps.	
4.1	
4.2	
4.3	
4.4	(4)

5. HIV/AIDS can spread through open wounds and cuts through contact with blood. Name FOUR precautions to keep in mind so as to avoid contact with their blood.	
5.1	
5.2	
5.3	
5.4	(4)

Total (20)

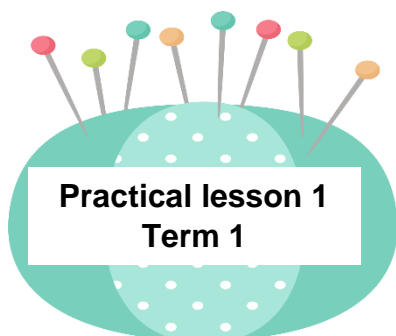

Consumer Studies

Module: Clothing production

Hygiene, Safety and Security

Name:	Grade 8
Marking guidelines	
1.1 Study the words below and reorganise them in the correct sequence/order when we are washing hands	
Rinse hands, apply soap, wet hands, dry hands, scrub hands	
1.1 Wet hands✓, apply soap✓ scrub hands✓, rinse hands✓, dry hands✓ (5)	
2. Electricity can be very dangerous if we use it incorrectly. Describe the precautions you need to take when using electricity from the following scenarios.	
2.1	You have wet hands:
2.1	Never touch anything electrical with wet hands ✓
2.2	Pulling the plug out of the wall:
2.2	Never pull out the plug by its cord. Take hold of the plug itself and remove it from the socket✓
2.3	You have 4 appliances:
2.3	Never overload a wall-socket. Make use of appropriate adaptors✓
2.4	You are walking barefooted:
2.4	Never use electrical appliance when you are barefoot✓
2.5	You need to make adjustments on your electric sewing machine:
2.5	Switch off your sewing machine when making adjustments✓
2.6	The electrical cord:
2.6	Examine old electric wires and flexes to see whether there are any broken places – repair immediately✓

(6)



	
3. State what the sign means	
3. There is a fire extinguisher ✓ (1)	
4. In the event of a fire, how will you operate the fire extinguisher? Name the FOUR steps.	
4.1	Pull the pin in the handle. ✓
4.2	Aim the nozzle at the base of the fire. ✓
4.3	Squeeze the lever slowly. ✓
4.4	Sweep from side to side ✓ (4)





5. HIV/AIDS can spread through open wounds and cuts through contact with blood. Name FOUR precautions to keep in mind so as to avoid contact with their blood.	
5.1	Avoid getting any of their blood into any sores or cuts that you may have on your skin. ✓
5.2	Also protect your eyes and your mouth. ✓
5.3	There should be gloves in all first aid kits – use them. ✓
5.4	If you pricked yourself or anyone else's finger and there is blood, discard of the pin (throw in dustbin) and clean the wound. ✓ (4)



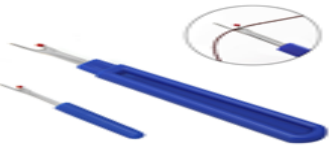

Total (20)

Grade 8 Term 1	Identify basic sewing equipment and tools <ul style="list-style-type: none"> - name their uses and - care
<p>It is important to use the correct equipment / tools when you sew. The equipment and tools are categorized into FIVE groups</p> <p>Sewing tools, Cutting tools, Marking tools, Ironing tools, Measuring tools</p>	

1. Sewing equipment and tools

1.1 Cutting Equipment / Tools			
Name	Properties	Use	Care
Dressmaker's scissors: 	<ul style="list-style-type: none"> • large handle • long, sharp blades 	<ul style="list-style-type: none"> • use only to cut fabric 	<ul style="list-style-type: none"> • Keep away from moisture • Do not drop • Pass scissors with the handle towards the person who is going to receive them. • Carry with sharp points downwards • Do not run with scissors in your hands • Do not cut paper with it. • Tighten the pivot screw and apply oil periodically • Always avoid cutting over pins.
Embroidery scissors: 	<ul style="list-style-type: none"> • small • sharp point 	<ul style="list-style-type: none"> • cut threads • finer cutting of corners and edges 	
Pinking scissors: 	<ul style="list-style-type: none"> • serrated blades 	<ul style="list-style-type: none"> • cut a zig-zag edge in fabric to prevent it fraying (unravelling) 	
Quick unpick / seam ripper: 	<ul style="list-style-type: none"> • sharp point • hook-like shape 	<ul style="list-style-type: none"> • take out sewing mistakes • use to cut open button holes 	
Operating a pair of scissors https://youtu.be/QYiWKFpA6Zg	Using a seam unpick https://youtu.be/3s_9lhVjl8	using a pinking shears https://youtu.be/bZNwa6P3QBY	using a thread snip https://youtu.be/aUwrqsuEjBI

1.2 Sewing Tools			
Name	Properties	Use	Care
Pins: 	<ul style="list-style-type: none"> • long • thin • rust free • sharp points 	<ul style="list-style-type: none"> • keep units together before sewing 	<ul style="list-style-type: none"> • Store in a pin box or on a pin cushion • Keep away from moisture • Discard blunt or broken pins
Needles: 	<ul style="list-style-type: none"> • A selection of different needles are available • No 1 needle is long and thick • No 10 needle is short and thin 	<ul style="list-style-type: none"> • Use a no 8 – 10 needle for general sewing • Use a thin needle for thin fabric. 	<ul style="list-style-type: none"> • Keep needles separate from pins • Keep needles away from moisture.
- Embroidery needle 	<ul style="list-style-type: none"> • Sharp point • Thin • Long eye 	<ul style="list-style-type: none"> • Use for embroidery 	
- Tapestry needle 	<ul style="list-style-type: none"> • Short, thick needle • Blunt point 	<ul style="list-style-type: none"> • Use for coarse embroidery on gauze or netting 	
Thimbles:	<ul style="list-style-type: none"> • A thimble should fit the middle finger. 	<ul style="list-style-type: none"> • Protects the finger when doing a lot of hand sewing 	<ul style="list-style-type: none"> • Keep safe with other needlework equipment.



			
1.3 Marking Tools			
Name	Properties	Use	Care
<p>Marking pen:</p> 	<ul style="list-style-type: none"> • Blue = water soluble • Purple = disappears after 24 hours 	<ul style="list-style-type: none"> • Make pattern markings on fabric 	<ul style="list-style-type: none"> • Keep in a safe place. • Use only on fabric.
<p>Tailor's chalk:</p> 	<ul style="list-style-type: none"> • Can be a colour pencil OR • Triangle shaped chalk 	<ul style="list-style-type: none"> • Make pattern markings on fabric 	<ul style="list-style-type: none"> • Keep in a safe place. • Use only on fabric. • They break easily, use with care
<p>Tracing wheel and - paper:</p> 	<ul style="list-style-type: none"> • A tracing wheel is used together with special dressmaker's carbon paper 	<ul style="list-style-type: none"> • Make pattern markings on the wrong side of the fabric 	<ul style="list-style-type: none"> • Store in a safe place • Use only on fabric



1.4 Sewing Thread

<p>Sewing thread:</p> 	<ul style="list-style-type: none"> • A variety is available • Use good quality thread • Cotton for cotton fabric • Polyester for polyester fabric 	<ul style="list-style-type: none"> • Use white or yellow thread for tacking. • Use a matching colour thread for sewing and over locking. 	<ul style="list-style-type: none"> • Secure end before storing • Keep neatly in a dust free container. • Do not stick needles in it.
--	---	--	---

The success of sewing will be determined by good ironing and pressing of the article/garment. It is important to iron after each step.

1.5 Ironing equipment

Equipment / Tools	Use	Care
<p>Iron</p> 	<ul style="list-style-type: none"> - A good steam iron is essential for pressing seams and smoothing out fabric. 	<ul style="list-style-type: none"> - Iron must be clean. - Use cooled off boiled water. - Empty iron after use. - Store in upright position after it has cooled down. - Do not wind the electrical cord around a warm iron.
<p>Ironing board</p>  <p>Sleeve board</p>	<ul style="list-style-type: none"> - Use with steam iron. 	<ul style="list-style-type: none"> - Ironing board must be sturdy. - Cover must be clean.

	<p>Use it for ironing sleeves and small parts.</p>	
<p>Press cloth: A big white calico cotton cloth.</p> 	<ul style="list-style-type: none"> - Use with iron to prevent shiny marks on fabric. 	<ul style="list-style-type: none"> - White cotton works the best. - Must be clean. - Store only when dry.
<p>A well-ironed garment will be:</p> <ul style="list-style-type: none"> • Flat, smooth and free of creases. • Seams and hems will not show through to the right side. • Garments will not have an over-pressed and limp look. • Fabrics with a dull surface should not be ironed until they become shiny. • Be careful when ironing stretchy fabric or loosely woven fabrics so that you do not change the shape of the garment. 		

<p>CLASS ACTIVITY</p>		<p>Grade 8 TERM 1</p>		
<p>SEWING EQUIPMENT AND TOOLS</p> <p>NAME _____</p>				
<p>Study the names of sewing equipment and tools in COLUMN A and match them to the properties and functions in COLUMN B. Write the correct matches in COLUMN C.</p>				
	<p>COLUMN A</p> <p>Sewing equipment/tool</p>		<p>COLUMN B</p> <p>Properties and function</p>	<p>COLUMN C</p>

1	Tape measure	A	For cutting fabric only	
2	Thread	B	Right size for fabric	
3	Dressmakers Scissors	C	Hold pins temporarily during sewing	
4	Pins	D	150 cm	
5	Needles	E	Transferring pattern markings	
6	Thimble	F	Spool pin	
7	Pincushion	G	Hold pieces of fabric before sewing	
8	Tracing wheel	H	Protect finger during sewing by hand	
		I	Feeds the fabric during sewing	
		J	Colourfast	

(16)

CLASS ACTIVITY **Marking guidelines**

GRADE 8 TERM 1

SEWING EQUIPMENT AND TOOLS

NAME _____

Study the names of sewing equipment and tools in COLUMN A and match them to the properties and functions in COLUMN B. Write the correct matches in COLUMN C.				
	COLUMN A Sewing equipment/tool		COLUMN B Properties and function	COLUMN C
1	Tape measure	A	For cutting fabric only	1. Tape measure D 150cm
2	Thread	B	Right size for fabric	2. Thread J Colourfast
3	Dressmakers Scissors	C	Hold pins temporarily during sewing	3. Dressmakers scissors A For cutting fabric only
4	Pins	D	150 cm	4. Pins G Hold pieces of fabric together before sewing
5	Needles	E	Transferring pattern markings	5. Needles B Right size for the fabric
6	Thimble	F	Spool pin	6. Thimble H Protect finger during sewing by hand
7	Pincushion	G	Hold pieces of fabric together before sewing	7. Pin cushion C. Hold pins temporarily during sewing
8	Tracing wheel	H	Protect finger during sewing by hand	8. Tracing wheel E For transferring pattern markings
		I	Feeds the fabric during sewing	

		J	Colourfast	
--	--	---	------------	--

(16)

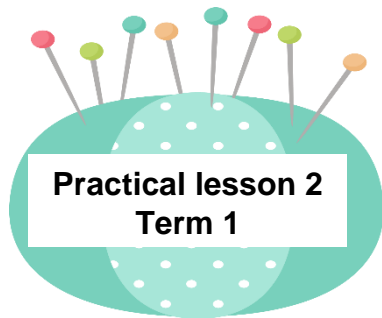

**Practical lesson 2
Term 1**

**Consumer Studies
Clothing or Soft Furnishing Option**

Identification of Needlework Equipment and tools

Name:	Grade 8
--------------	----------------

**Practical lesson 2 – Term 1 – Identification of Needlework Equipment.
Complete the name and use of the equipment displayed at the number**

1. Give any THREE categories of needlework tools you learnt about

1.1 _____



1.2 _____





1.3 _____

(3)

2. **Complete the name and use of the equipment displayed in COLUMN A.
Give its use in COLUMN B**

(14)

	2.1 COLUMN A The tool	2.2 COLUMN B Name of tool	2.2 COLUMN C Use of tool	
				
				

3. Describe a well pressed article.



(3)



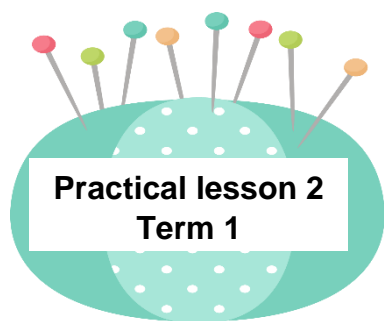

TOTAL: 20



Consumer Studies
Clothing or Soft Furnishing Option

Identification of Needlework Equipment and tools



Name:	Grade 8		
Marking guidelines			
Practical lesson 2 – Term 1 – Identification of Needlework Equipment. Complete the name and use of the equipment displayed at the number			
1. Give any THREE categories of needlework tools you learnt about			
1.1 Sewing tools, cutting tools, marking tools, ironing tools, measuring tools			
1.2			
1.3 (Any 3) (3)			
2 Complete the name and use of the equipment displayed in COLUMN A. Give its use in COLUMN B (14)			
	2.1 COLUMN A The tool	2.2 COLUMN B Name of tool	2.2 COLUMN C Use of tool
		Needles	Use no 8 – 10 needle for general sewing Use a thin needle for thin fabric.
		Iron/Steam iron	A good steam iron is essential for pressing seams and smoothing out fabric.

		<p>Cutting shears</p>	<p>Use to cut fabric only</p>	
		<p>Dressmakers' pins</p>	<p>Keep fabrics pieces together before sewing</p>	
		<p>Large white calico cloth</p>	<p>Use with iron to prevent shiny marks on fabric</p>	
		<p>Pinking shears</p>	<p>Cut a zig-zag edge in fabric to prevent it fraying (unravelling)</p>	
		<p>Embroidery scissors</p>	<p>Cut threads Finer cutting of corners and edges</p>	

3 Describe a well pressed article.

- Lies flat, smooth without creases ✓
 - Seams and hems will not show through to the right side. ✓
 - Garments will not have an over-pressed and limp look ✓.
 - Fabrics with a dull surface should not be ironed until they become shiny. ✓
 - Be careful when ironing stretchy fabric or loosely woven fabrics so that you do not change the shape of the garment/article ✓
- (Any 3) (3)

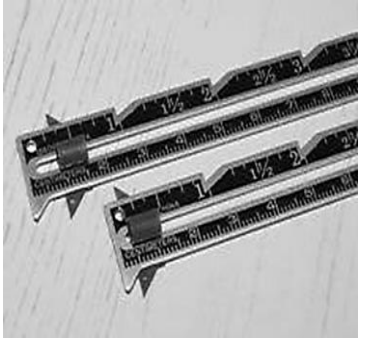
TOTAL: 20

<p>Grade 8 Term 1</p>	<p>Identify basic measuring equipment and tools</p> <ul style="list-style-type: none"> - name their uses and - care 		
<p>It is important to use the correct measuring equipment / tools when you sew.</p>			
<p>Measuring tools (equipment)</p>			
<p>Name</p>	<p>Properties</p>	<p>Use</p>	<p>Care</p>
<p>Tape measure:</p> 	<ul style="list-style-type: none"> • 150 cm in length • made of non-stretch material • marked in mm and cm on both sides • metal tips to ensure accuracy 	<ul style="list-style-type: none"> • Taking of body measurements – width and length • Measure fabric • Start measuring at the metal tip 	<ul style="list-style-type: none"> • Wipe with a damp cloth • Store rolled up
<p>Sewing gauge:</p> 	<ul style="list-style-type: none"> • A short metal or plastic ruler with an adjustable sliding marker 	<ul style="list-style-type: none"> • measure small distances like seams, hems and button holes 	<ul style="list-style-type: none"> • Keep in a safe place
<p>Measuring card</p> 	<ul style="list-style-type: none"> • Can be home made with stiff cardboard 	<ul style="list-style-type: none"> • Use to measure seams, hems and buttonholes. 	<ul style="list-style-type: none"> • Do not bend • Keep dry

<p>Ruler</p> 	<ul style="list-style-type: none"> • Made of plastic or wood. • Calibrated in both mm and cm 	<ul style="list-style-type: none"> • Not commonly used in sewing • It is used to measure short measurements in a more steady way than a tape measure • Can be used to measure hems accurately 	<ul style="list-style-type: none"> • Do not break
---	--	--	--

Identifying different measurements on measuring tools

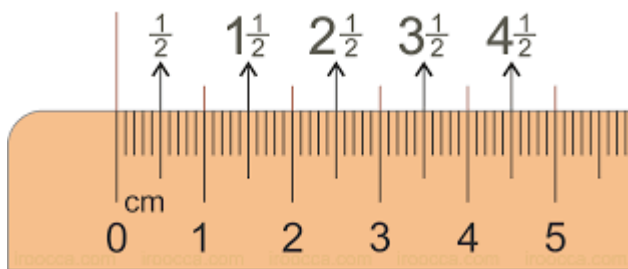
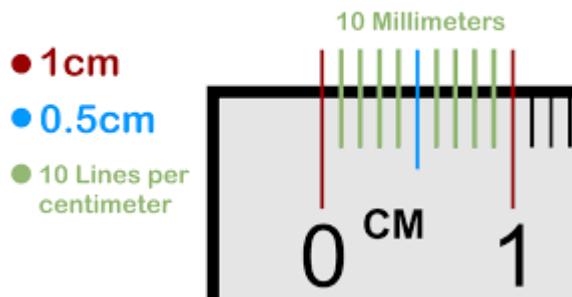



Measuring card with 1cm, 1.5cm, 2cm, 2.5cm, 3.5cm, 6cm

Body measurements – Recap

A standard **body measurements chart** can be found on all commercial patterns. You need to take your body measurements first to determine which size pattern you need to buy.

When choosing a pattern for a shirt, blouse, or top, use your bust measurement as guide. Dresses, skirts and trousers are based on waist and hip measurement.

Choose a pattern according to your bust and hip measurement and make any adjustments before laying out and cutting the fabric.

Body measurements:

Take your body measurements with a **tape measure**.

Take your measurements as follow:

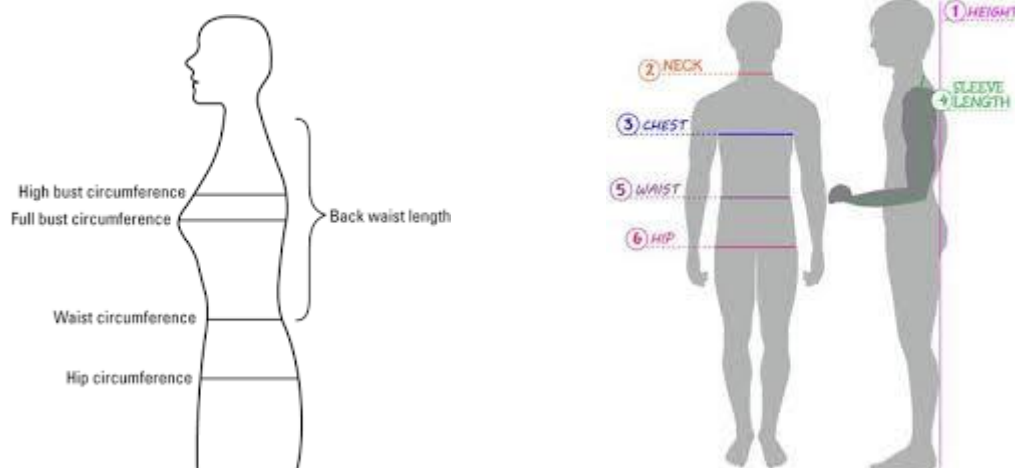

Bust/Chest: keep the measuring tape flat and measure around the broadest part.

Waist: measure around the natural waistline.

Hips: measure about 20 cm below the waistline, around the broadest part of the hips.

Neck-to-waist: measure from the prominent bone at the back of the neck to the waistline.

CLASS ACTIVITY

GRADE 8 TERM 1

USING MEASURING EQUIPMENT

Body measurements:

1. Using hard paper make your own measuring card with 5mm, 1cm, 1.5cm,
2. In pairs take your body measurements with a **tape measure**.

Take your measurements as follow:

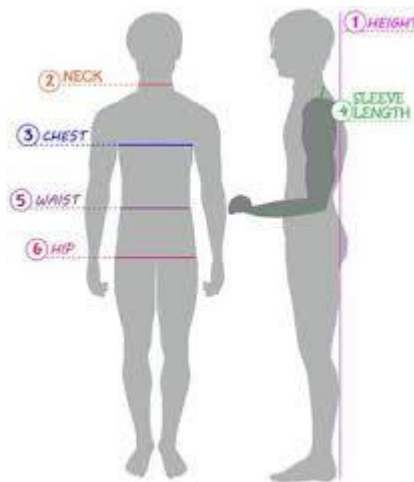
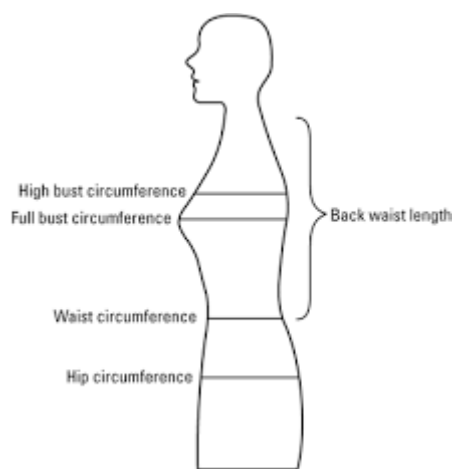

Bust/Chest: keep the measuring tape flat and measure around the broadest part.

Waist: measure around the natural waistline.

Hips: measure about 20 cm below the waistline, around the broadest part of the hips.

Neck-to-waist: measure from the prominent bone at the back of the neck to the waistline.

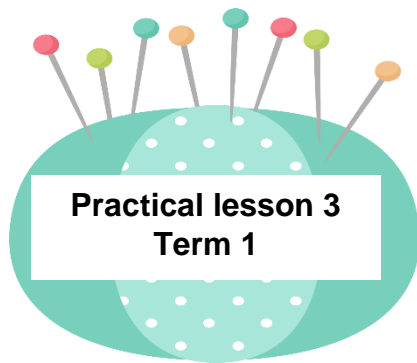

Consumer Studies
Clothing or Soft Furnishing Option
Measuring equipment and tools

1. Use a tape measure to draw lines in your book of the following lengths:
 - 2.1 15cm
 - 2.2 9cm
 - 2.3 12,5cm
 - 2.4 5cm
 - 2.5 2,5cm

(5)

2. Use stiff cardboard to make your own measuring card. The following measurements must be displayed:
 - 3.1 3cm
 - 3.2 1cm
 - 3.3 1,5cm

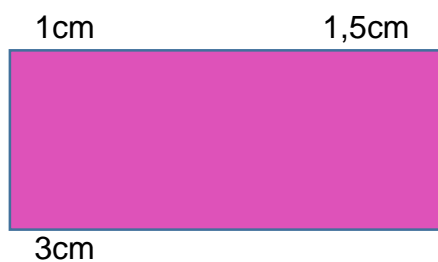

(5)

3. In pairs, demonstrate the correct use of the tape measure by taking the following measurements of your friend:

3.1 Waist measurement: _____

3.2 Hip measurement: _____

(5)

4. Use the words in the block to complete the classification of tools and equipment.

Dressmaker's scissor	Ironing board	Sewing gauge
Embroidery needles	Measuring tape	Steam iron
	Sleeve board	

Classification of sewing tools / equipment

Ironing equipment	Measuring tools/equipment

(5)

Total = (20)

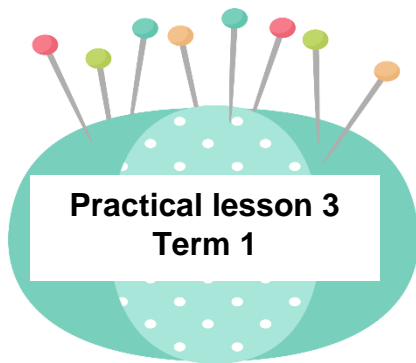

Marking Guidelines

**Consumer Studies
Clothing or Soft Furnishing Option
Measuring equipment and tools**

1. Use a tape measure to draw lines in your book of the following lengths:

1.1 15cm

1.2 9cm

1.3 12,5cm

1.4 5cm

1.5 2,5cm

(5)

2. Use stiff cardboard to make your own measuring card. The following measurements must be displayed:

2.1 3cm

- 2.2 1cm
- 2.3 1,5cm

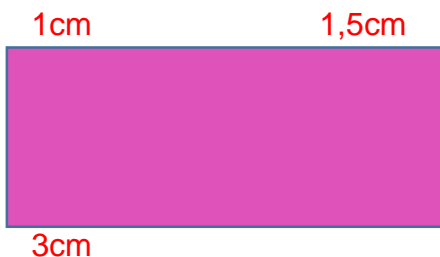

Straight cut edges **clear markings** (5)

3. In pairs, demonstrate the correct use of the tape measure by taking the following measurements of your friend:

- 3.1 Waist measurement: __ **measure around the natural waistline** __
- 3.2 Hip measurement: ___ **measure about 20 cm below the waistline, around the broadest part of the hips** _____ (5)

4. Use the words in the block to complete the classification of tools and equipment.

Dressmaker’s scissor	Ironing board	Sewing gauge
Embroidery needles	Measuring tape	Steam iron
	Sleeve board	

Classification of sewing tools / equipment

Ironing equipment	Measuring tools/equipment
<p>Ironing board</p> <p>Sleeve board</p> <p>Steam iron</p>	<p>Measuring tape</p> <p>Sewing gauge</p>
(5)	

Total = (20)

Grade 8 Term: 1	Explain and demonstrate: Basic Hand stitches for sewing and embroidery
------------------------	---

Hand stitches

1. Types of Basic hand stitches for sewing and embroidery:

For most projects you will need to do some sewing by hand – for example, making hems and stitching trickier areas.

1.1 Tacking / Basting Stitch

Simple tacking stitches are used for holding two pieces of fabric together and making temporary hems.

Since the stitches won't be staying in the fabric, you can use a knot to start off.

Just use a single thread to make straight stitches

1.1.1 Even tacking

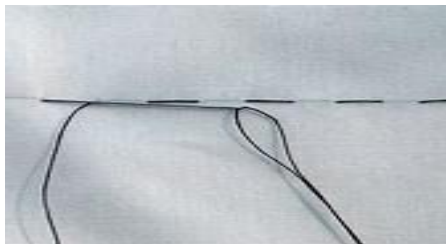

1.1.2 Uneven tacking

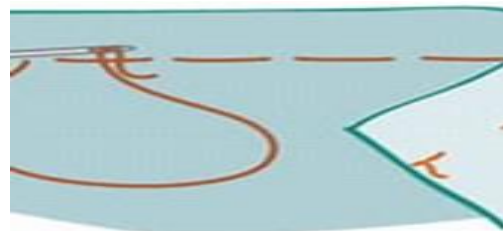

1.2 Running stitches:

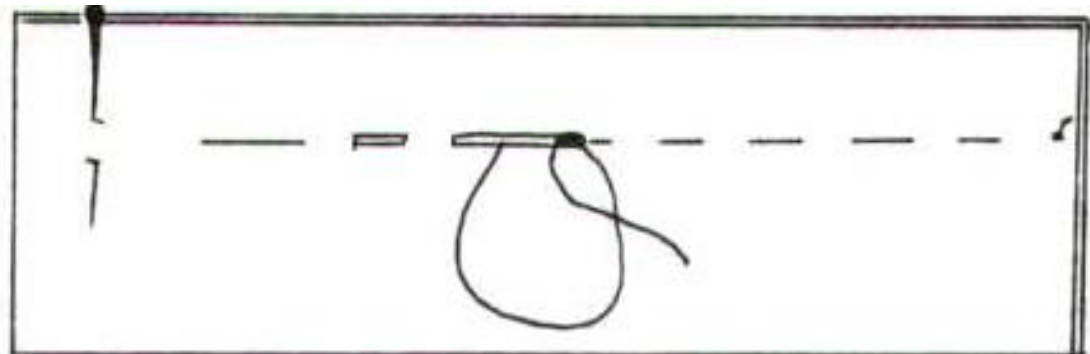

This

stitch is similar to tacking and is generally used for decorating a finished project. Simply bring your needle up and down through the fabric at regular intervals to create evenly-spaced stitches. Make sure that all the stitches are the same length and the spaces between them too – this is particularly important if you are using it as an embellishment. It is also used for quilting.



1.3 Back stitch / stem stitch.

A strong stitch that is used for joining two pieces of fabric together permanently. It is stronger and firmer than the running stitch. It can be used if a sewing machine is not available to sew. It's also a decorative embroidery stitch.

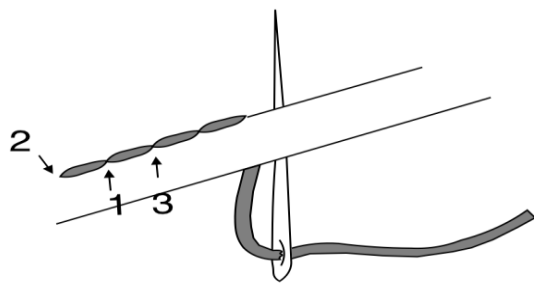

back stitch

Go up through your fabric at 1...
Back down at 2..
Up at 3...
Back down at 1...
Keep going back on yourself



1.4 Threaded backstitch

Use the basic back stitch as explained before and add threads to serve as decoration. Different colour threads can be used. This is an easy way to add colour to your patchwork, once you are done joining the strips together.

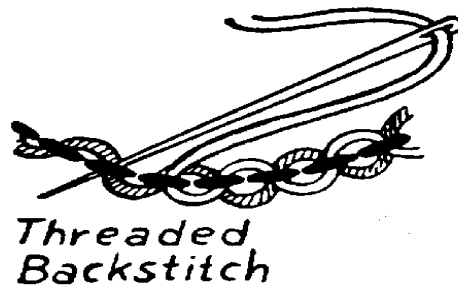

1.5 Slip stitch:

The slip stitch is a very important sewing stitch to know. It is perfect for closing up small holes you leave in order to flip a project right side out.



1.6 Blanket stitch

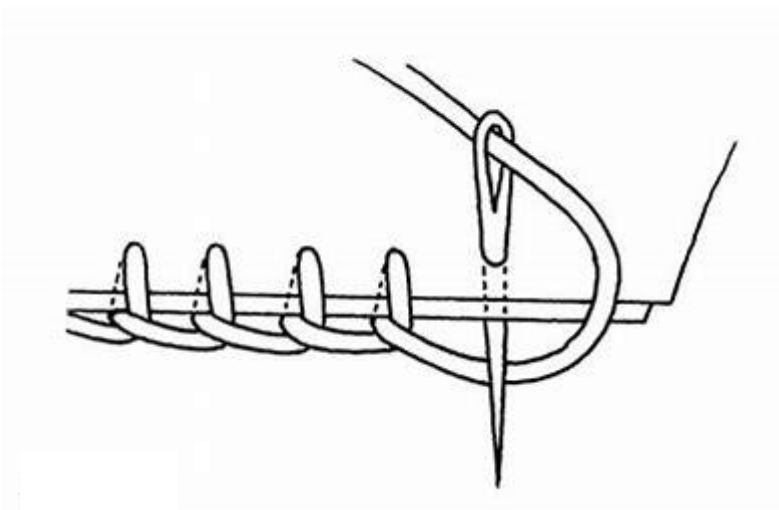

1.7 Herringbone stitch



Basic stitches to do patchwork and quilting by hand:

2.1 Running stitches:

This stitch is similar to tacking and is generally used for decorating a finished project. Simply bring your needle up and down through the fabric at regular intervals to create evenly-spaced stitches.

Make sure that all the stitches are the same length and the spaces between them too – this is particularly important if you are using it as an embellishment.

It is also used for quilting.

Back stitches – basic backstitch / stem stitch.

A strong stitch that is used for joining two pieces of fabric together permanently.

It is stronger and firmer than the running stitch. It can be used if a sewing machine is not available to sew.

It's also a decorative embroidery stitch

Embroidery stitches:

Basic embroidery stitches are useful for decorating items. You can decorate clothes, sheets, pillowslips, cushions, bags and so on. Decoration adds value to an item, making it unique and accentuating your personal style.

3.2 Threaded backstitch

Use the basic back stitch as explained before and add threads to serve as decoration.

Different colour threads can be used.

This is an easy way to add colour to your patchwork, once you are done joining the strips together.

Embroidery Stitches

Embroidery thread

Cotton embroidery floss or Stranded cotton:

Most commonly used for hand embroidery.
You can divide the strands and use 1, 2, 3 or 4 strands.
Very affordable with a wide range of colours



Perle thread:

This is a thicker cotton thread and non-divisible.
It comes in different thicknesses.
It has a sheen and comes in a variety of colours.



Running Stitch

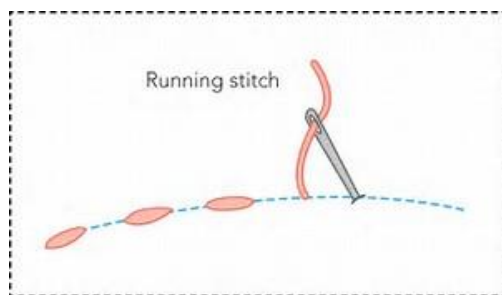

Stepped Running Stitch

This stitch is similar to tacking and is generally

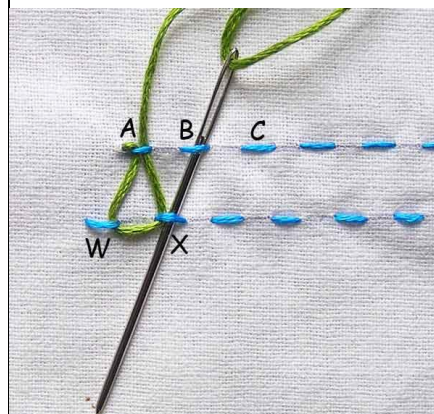

used for **decorating a finished project** and for **gathering fabric**.

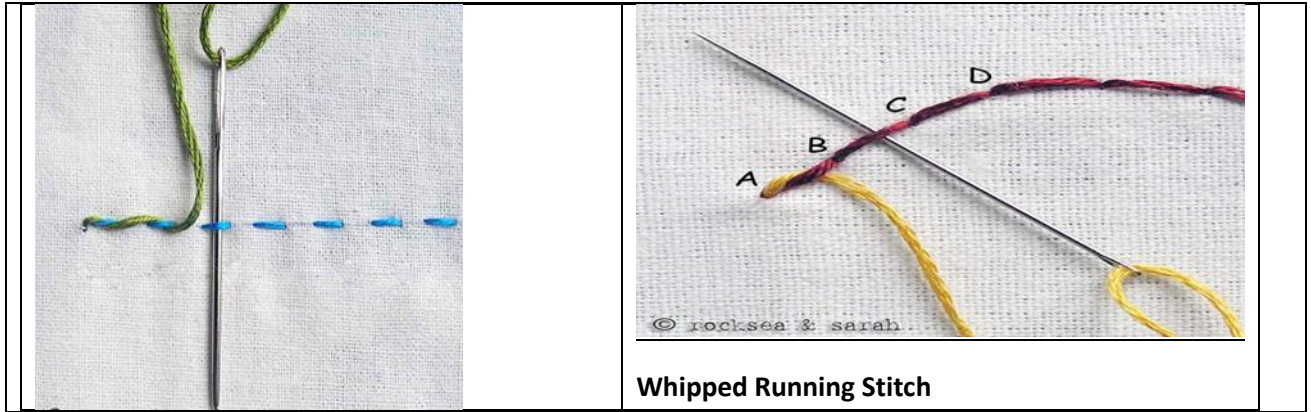

CLASS ACTIVITY

GRADE 8 TERM 1

NAME _____

Worksheet: Basic stitches

1. Name any FIVE hand sewing stitches.

1.1 _____

1.2 _____

1.3 _____

1.4 _____

1.5 _____ (5)

2. Name a hand sewing stitch used to sew gathers. _____ (1)

3. List THREE types of tacking stitch. _____ (3)

4. Which stitch can you use for hemming _____ (1)

TOTAL [10]

CLASS ACTIVITY

Marking guidelines

GRADE 8 TERM 1

Worksheet: Basic stitches

1. List THREE basic hand sewing stitches. Tacking stitch, back stitch, slip stitch, running stitch, hemming stitch Any 3	(3)
2. Name TWO embroidery stitches Herring bone stitch, Chain stitch, Blanket stitch Any 2	(2)
3. Name a hand sewing stitch used to sew gathers. Running stitch	(1)
4. List THREE types of tacking stitch. Even tacking, Uneven tacking, Long and short tacking	(3)
5. Name a stitch used for hemming Slip stitch/hemming stitch	(1)
TOTAL [10]	

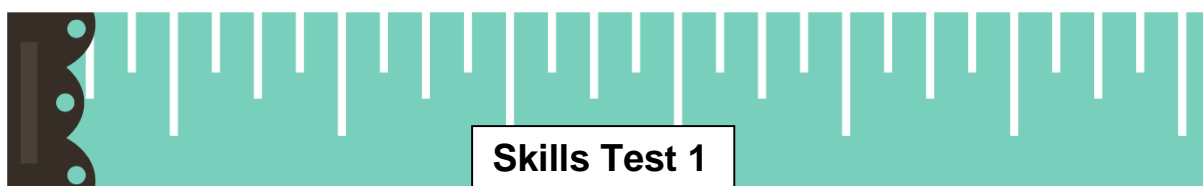

CONSUMER STUDIES	OPTION: Clothing / Soft furnishing / Patchwork Production	
Basic hand stitches 20		
Name:		Grade 8 & 2
TASK: Read the instructions and complete the practical task below.		
INSTRUCTION	PASTE SWATCH HERE	
1. On a fabric swatch, demonstrate: Running stitches	(5)	

2. On a fabric swatch, demonstrate: Backstitches / Stem stitch	(5)
3. On a fabric swatch, demonstrate: Blanket stitch	(5)
4. On a fabric swatch, demonstrate: Slip stitches	(5)
(5) 20	

Consumer Studies

Clothing or Soft Furnishing Option

Grade 8

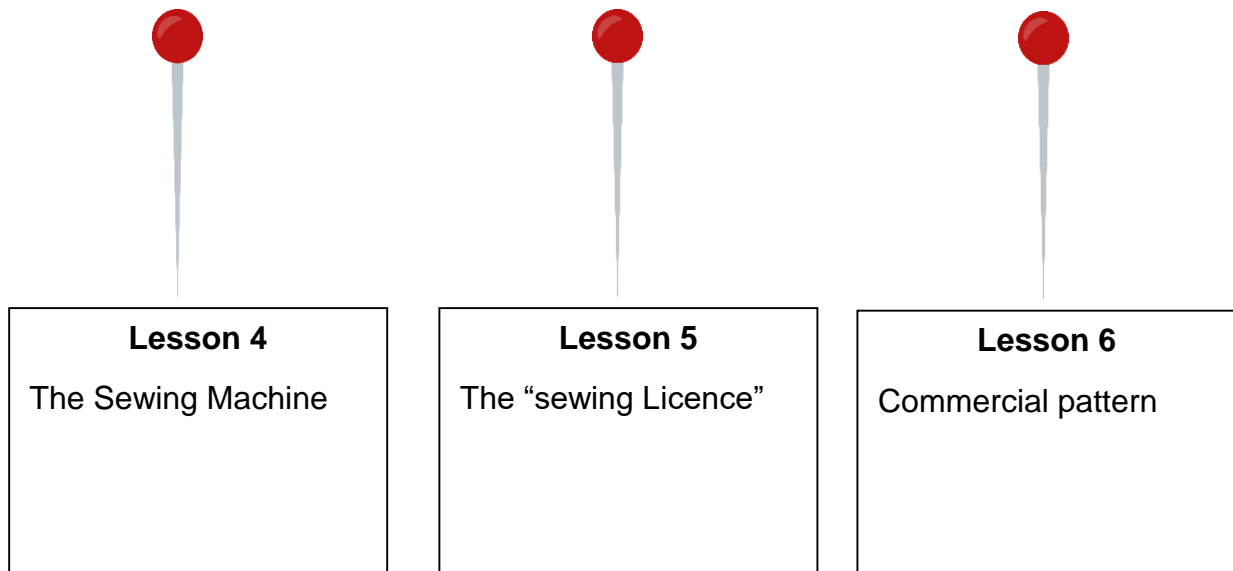
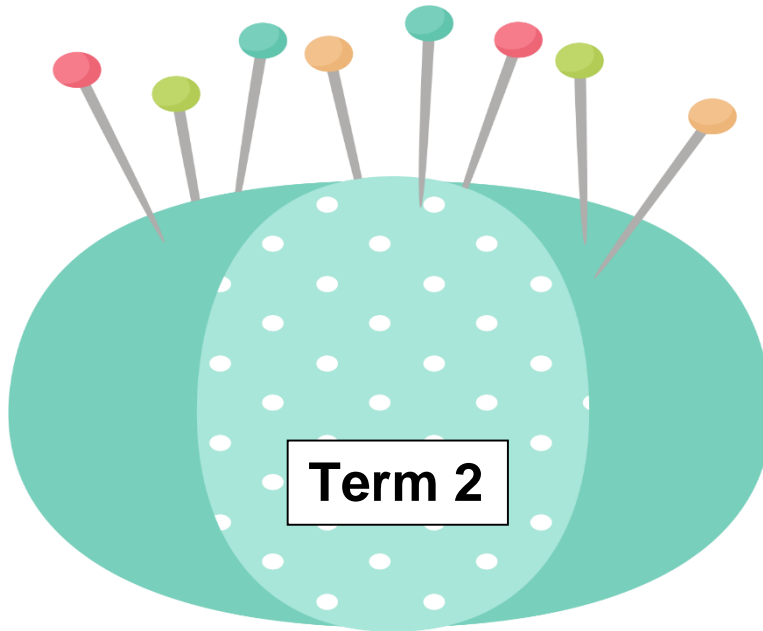

The Sewing Machine

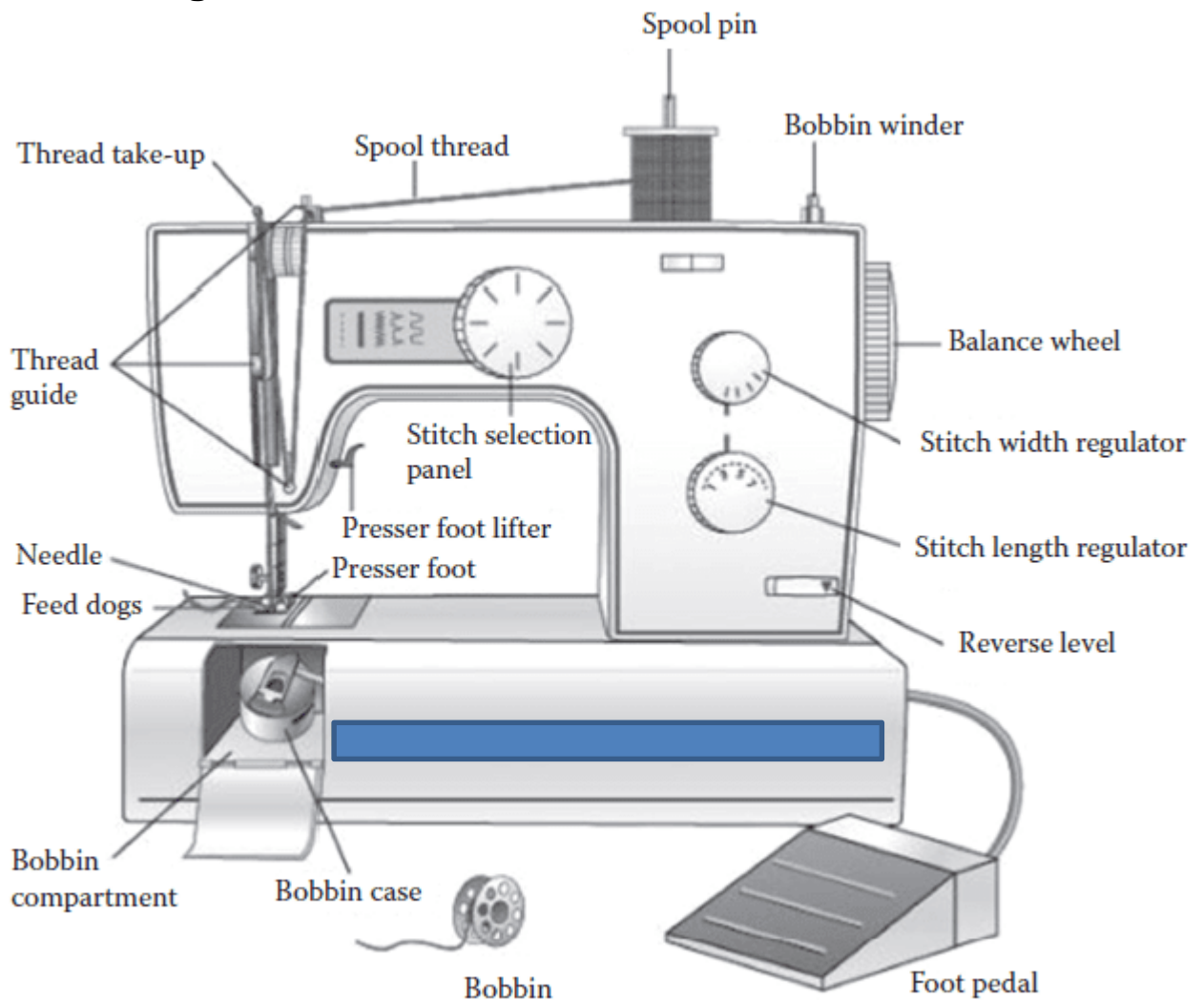

Uses of the parts of a sewing machine

1. Spool pin hold sewing thread from the top
2. Bobbin holds the lower sewing thread from the under side
3. Bobbin case houses the bobbin
4. Thread guides hold the upper thread from the spool to through to the needle
5. Take up lever pulls the thread from the spool and holds it tight
6. Presser foot holds the fabric in position during sewing
7. Presser foot lever lifts and lowers the presser foot
8. Bobbin winder fills the thread onto the bobbin
9. Hand wheel controls the machinery of the machine
10. Stitch length regulator controls the size of the stitches
11. Hand wheel screw controls which parts of the machine can be moved

3. Threading the Sewing machine:

All sewing machines are threaded in a similar way. You can follow the instructions in the manual or use the diagram as a guide.

The correct threading is important to ensure that the stitches will be perfect.



4. Winding of the bobbin:

Follow the instructions in the manual to ensure that the bobbin is winded correctly.

Wind the bobbin evenly to ensure even stitching.

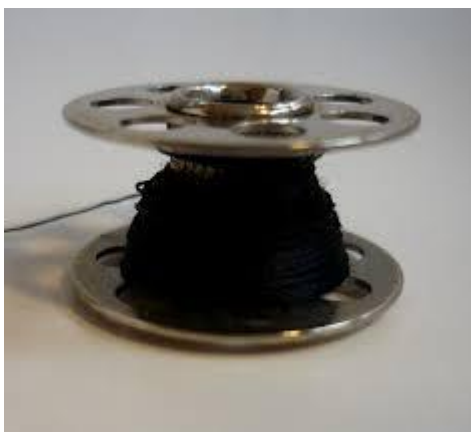

is
the



Wrong
Correct
The bobbin
placed in
bobbin



holder in a specific way. Follow the instructions in the manual and place the bobbin holder in the machine. Make that you sure anchor it securely.



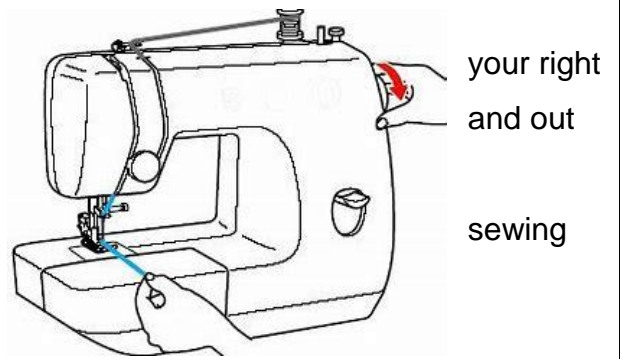

5. How to pull the lower thread up:

Before you can start sewing, you need to pull up the lower thread.

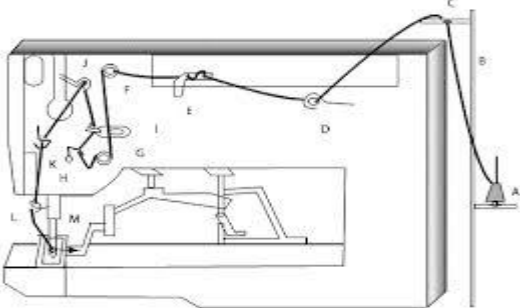
- Hold the top thread in you left hand
- Turn the balance wheel towards you with your right hand – the needle must pass into the hole again to bring the lower thread up
- Pull both threads towards the back of the machine



PARTS OF A SEWING MACHINE	Function/Use
	<p>A bobbin</p> <p>For winding the bottom thread</p>
	<p>Bobbin case</p> <p>Holds the bobbin</p>
	<p>Spool pin</p> <p>Holds the thread for the top thread</p>
	<p>Thread guides</p> <p>Guides the thread from the spool pin</p>

 <p>thread take-up lever</p>	<p>The thread take up lever</p> <p>Moves upwards and downwards to tighten the thread when the stitch has been completed</p>
	<p>A presser foot</p> <p>Holds the fabric firmly in position during stitching</p>
	<p>Feed dogs</p> <p>Moves the fabric backwards after each stitch is made</p>
 <p>Lever to lift foot</p>	<p>The presser foot lever</p> <p>Raises and lowers the presser foot</p>



The feed plate

Provides a smooth surface for sewing and is often marked with stitching guidelines



Automated bobbin winder



Bobbin winder on a sewing machine

Bobbin winder

Is used to wind thread around the bobbin automatically



Stitch length regulator,

sets the length of the stitches

	<p>The hand wheel</p> <p>controls the up and down motion of the needle and needle bar</p>
	<p>Hand wheel screw</p> <p>is used to start or stop (tightening or stop (loosening) the stitching mechanism when winding the bobbin</p>

	<p>Tension dial</p> <p>Adjusting the tension on a sewing machine to control how tight the thread is</p>
---	--

CLASS ACTIVITY

GRADE 8 TERM 2

NAME: _____

Worksheet: Parts of the sewing machine and its uses

1. Give the relationship between a bobbin and a bobbin case

1.1 _____



(2)



2. Identify TWO sewing tools for each of the three categories of basic sewing equipment and tools displayed on the teacher's table and fill in the columns following the instructions below.

2.1 In Column A name the machine part below the machine part

2.2 In Column B write down what it is used for

(10)



	2.1 COLUMN A Name of part	2.2 COLUMN B Use
1		
2		
3		

4		
5		

(10)

3. From the list of parts of sewing machines, identify the correct name for the part for the THREE pictures given below.

Spool pin, take up lever, thread guides, bobbin winder, feed plate (3)

3.1	3.2	3.3
		

TOTAL [15]

Marking guidelines

Worksheet: Parts of the sewing machine and its uses



4 Give the relationship between a bobbin and a bobbin case



1.1 A bobbin is placed inside a bobbin case✓ to provide the thread from the Bottom✓ and control the tension✓ Any
2 (2)

5 Identify TWO sewing tools for each of the three categories of basic sewing equipment and tools displayed on the teacher’s table and fill in the columns following the instructions below.

5.1 In Column A name the machine part below the machine part
5.2 In Column B write down what it is used for

(10)

	2.1 COLUMN A Name of part	2.2 COLUMN B Use
1	 <p>Stitch length regulator</p>	Sets the length of the stitches
2	 <p>Hand wheel screw</p>	Used to start or stop the stitching mechanism when winding the bobbin

3		<p>Controls the up and down motion of the needle and needle bar</p>
<p>Hand wheel</p>		
4		<p>Feeds the fabric backwards after each stitch is made</p>
<p>Feed dog</p>		
5		<p>Moves upwards to tighten the thread when the stitch has been completed</p>
<p>Take up lever</p>		

(10)

6 From the list of parts of sewing machines, identify the correct name for the part for the THREE pictures given below.

Spool pin, take up lever, thread guides, bobbin winder, feed plate

3.1 Feed plate	3.2 Spool pin	3.3 Bobbin winder
----------------	---------------	-------------------



TOTAL [15]

CLASS ACTIVITY 2	SEWING LICENCE PRACTISE
<ul style="list-style-type: none"> • 1. Straight line (2) • 2. Zig zag (2) • 3. Diagonal line (2) • 4. Circle (2) • 5. Corners (2) 	<p style="text-align: center;">TOTAL MARKS 10</p>

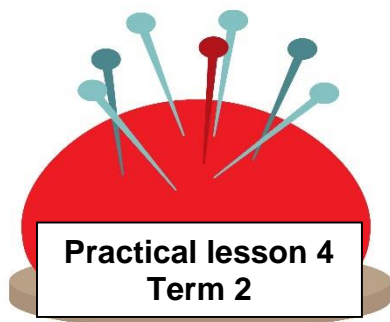

Consumer Studies

Clothing or Soft Furnishing Option

The Sewing Machine: parts, functions, thread, winding bobbin

Name: _____			Grade 8
DATE	ASSESSMENT	MARK	NOTES
	<p>Threading the sewing machine:</p> <ul style="list-style-type: none"> • Place thread on spool pin • Thread 1st thread guide • Straight down • Around bottom hook • Straight up • Hook around top thread guide 		

	<ul style="list-style-type: none"> • No crossed thread • Straight down • Through bottom thread guide • Thread the needle 	<hr/> 10	
	<p>Winding of the bobbin:</p> <ul style="list-style-type: none"> • Bobbin on bobbin winder • Thread from spool crosses around top guide • Loosen balance wheel • Wind bobbin • Fasten balance wheel • Place in bobbin case 	<hr/> 6	
	<p>Bringing the lower thread up:</p> <ul style="list-style-type: none"> • Hold the top thread in left hand • Turn balance wheel towards you – needle in and out • Take bottom thread out • Pull both threads to the back – ready to sew 	<hr/> 4	
	TOTAL	20	

Total = 20

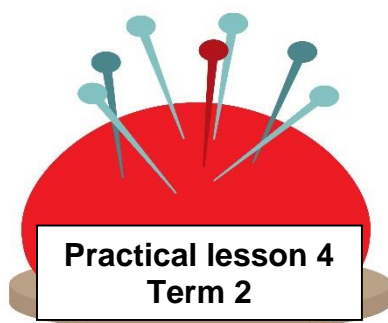

Consumer Studies

Clothing or Soft Furnishing Option

The Sewing Machine: parts, functions, thread, winding bobbin

Marking guidelines			Grade 8
Name: _____			
DATE	ASSESSMENT	MARK	NOTES
	<p>Threading the sewing machine:</p> <ul style="list-style-type: none"> • Place thread on spool pin • Thread 1st thread guide • Straight down • Around bottom hook • Straight up • Hook around top thread guide • No crossed thread • Straight down • Through bottom thread guide • Thread the needle 	<hr/> 10	
	<p>Winding of the bobbin:</p> <ul style="list-style-type: none"> • Bobbin on bobbin winder • Thread from spool crosses around top guide • Loosen balance wheel • Wind bobbin • Fasten balance wheel • Place in bobbin case 	<hr/> 6	
	<p>Bringing the lower thread up:</p> <ul style="list-style-type: none"> • Hold the top thread in left hand • Turn balance wheel towards you – needle in and out • Take bottom thread out • Pull both threads to the back – ready to sew 	<hr/> 4	

	TOTAL	20	
--	--------------	-----------	--

Total = 20

1. Practise using the sewing machine:

Use paper, gingham or unbleached cotton and draw the lines on it as shown below.

- Sew straight lines by using the inside edge of the presser foot.
- Corners – stop with needle in the corner, lift the pressure foot and turn, put the pressure foot down and continue.
- Curved lines - follow the curved lines

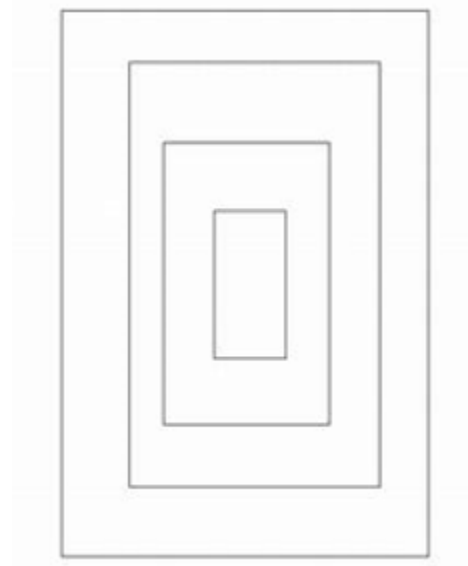
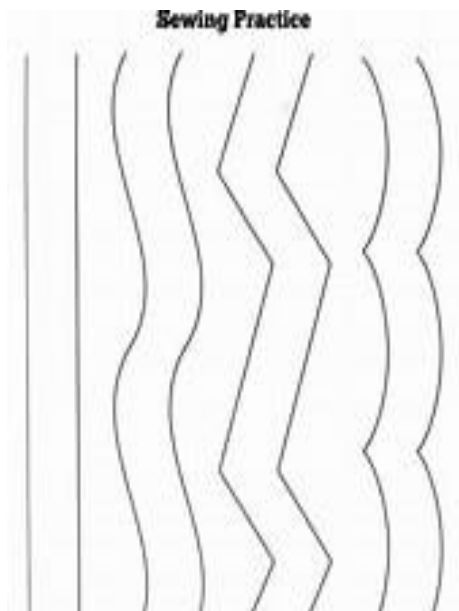

2. Practise on a fabric swatch:

- start and finish
- reverse stitching
- straight sewing
- sew straight lines by holding the side of the pressure foot on the side of the fabric and then on the previous sewing lines
- practise straight lines until it becomes easy to sew

CLASS ACTIVITY 2	SEWING LICENCE PRACTISE
• 1. Straight line	(2)
• 2. Zig zag	(2)
• 3. Diagonal line	(2)
• 4. Circle	(2)
• 5. Corners	(2)
• TOTAL MARKS	10

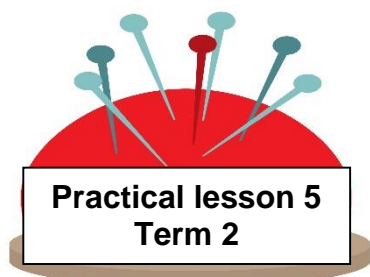

Consumer Studies

Clothing or Soft Furnishing Option

The “sewing licence”

Name: _____	Grade 8
-------------	---------

1. Use double fabric swatch – 15cm x 15cm – sew straight lines.

DATE	ASSESSMENT	MARK	NOTES
	<p>Straight sewing – on 15cm x 15cm double fabric swatch</p> <ul style="list-style-type: none"> • Fabric under pressure foot • Hold side of fabric on 15mm mark • Put pressure foot down • Hold both threads • Turn balance wheel towards you • Needle inside fabric • Start and sew 3 stitches • Reverse 3 stitches • Start sewing • Sew straight line on 15mm mark • Stop at end of fabric – not off fabric • Reverse 3 stitches • Stop – turn balance wheel until needle is in top position • Lift pressure foot • Pull threads towards back and snip 	<hr style="width: 50px; margin: 0 auto;"/> 15	
	<p>Sew straight lines:</p> <ul style="list-style-type: none"> • Using the 1st sewing line as a guide – sew five more straight lines as above 	<hr style="width: 50px; margin: 0 auto;"/> 5	
	TOTAL	<hr style="width: 50px; margin: 0 auto;"/> 20	

Term: 2	Pattern envelope, instruction sheet, pattern markings and laying out of pattern on fabric
Commercial patterns	
Every person who wants to make his/her own clothes/soft furnishing/patchwork can easily do so by using a commercial pattern. You can choose a pattern from a	

pattern catalogue which is available at needlework shops. Each catalogue is divided into different categories to make it easy to locate the pattern you will need. To be able to use a pattern, it is important to know and understand the information available on the pattern envelope, instruction sheet and pattern pieces.

1. The pattern envelope:

1.1 The information which can be found on the front of the pattern envelope:

- The **name** of the pattern
- The **number** of the pattern
- The **size** of the pattern
- **Colour drawings** or photographs of different views.

1.2 The information which can be found on the back of the pattern envelope:

- Required **amount** of fabric, according to different widths.
- **Recommended fabric** for the pattern.
- Required **notions**, for example buttons, zip, interfacing, etc.
- Sketches of the **back views**.
- **Body measurement** chart. (when applicable)

2. The instruction sheet:





The information which can be found on the instruction sheet:

- Sketches of the different pattern **views**.
- Sketches of **pattern pieces**.
- List of all **numbered** pattern pieces.
- How to **lay out** the pattern pieces on the fabric.
- **Step-by-step instructions** for completing the garment.
- **General sewing notes** on how to use the pattern.

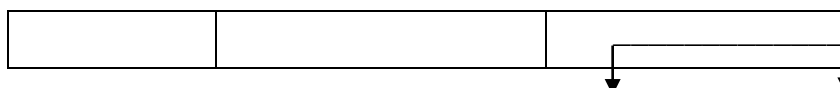
3. The tissue-paper pattern pieces:

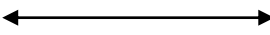
These basic **pattern markings** can be found on each pattern piece:

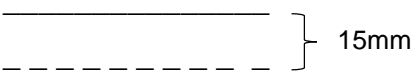

Place on fold:	Place the pattern piece on the folded edge of the fabric	
Grainline:	Align the pattern's grain line with the fabric's lengthwise grain	
Notches:	Small marks made on the pattern to ensure that pattern pieces can match.	
Cutting line:	The outer edge of the pattern where you will cut	
Seam allowance:	The space between the side of the fabric and the sewing line = 15mm	
Stitching line:	The line on which to sew – 15mm from the edge of the fabric	

4. The laying out of the pattern on the fabric:

- Fold the fabric **double** with the selvages together.
- Remember that **right sides** must be together.
- Place the fabric **flat** on a big table.

- Choose the pattern pieces according to the **information** on the instruction sheet of the pattern.
- Lay the pattern pieces out according to **the lay out diagram**.
- First place the **largest** parts and then the smaller parts of the pattern.
- Make sure that the **grain line** on the pattern corresponds with the **lengthwise grain** of the fabric.
- **Pin** the pattern onto the fabric with pins.

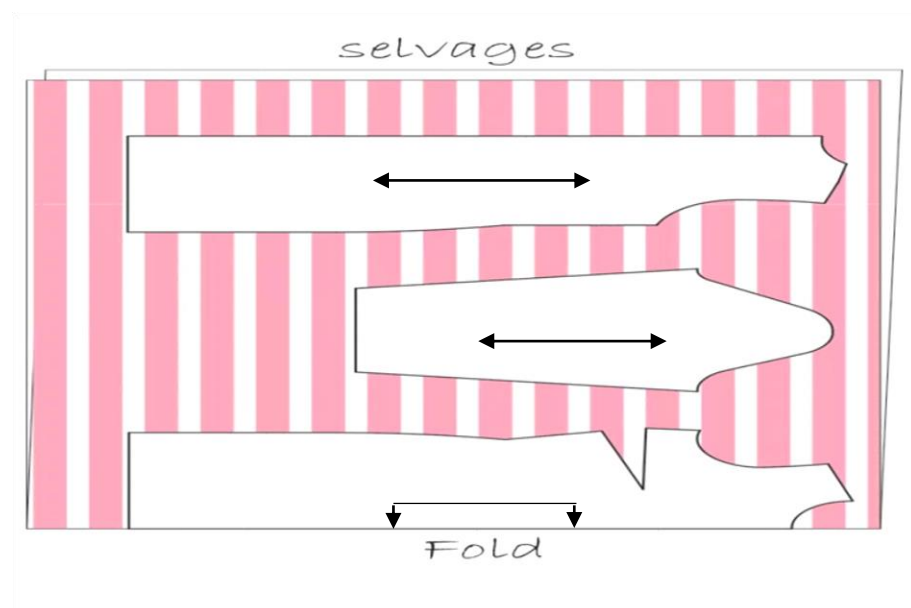

5. Cutting out the pattern pieces on the fabric:

- Keep the fabric flat on the cutting surface.
- Use a **sharp** pair of dressmaker's scissors.
- Cut with **long, even** strokes along the cutting line of the pattern.
- **Never lift** the fabric from the table.
- Move **around** the table whilst cutting.
- **Transfer** the necessary pattern markings on the fabric.

6. Transferring pattern markings onto the fabric pieces:

The pattern markings that you need to transfer onto the fabric will show you where sections are joined (notches) and details like darts, pleats, zip placement, etc.

Select the marking method most suited for the fabric:

- Marking pen or pencil
- Pins and tailor's chalk
- Tracing wheel and carbon paper

CLASS ACTIVITY

GRADE 8 TERM 2

Pattern

1. Name the pattern markings indicated on the dolls dress pattern pieces

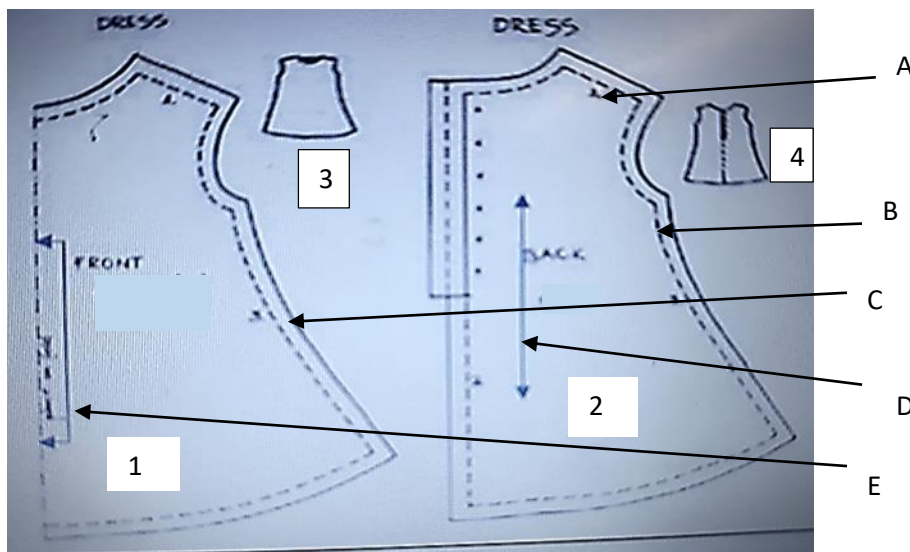

(5)

2. Identify what numbers 3 and 4 diagrams on the pattern indicate (2)
3. Give the name of the space between the broken line in the pattern and the continuous line around the pattern pieces (1)
4. Explain why TWO pieces will be cut from pattern piece 2 (2)

(10)

CLASS ACTIVITY

GRADE 8 TERM 2

Pattern

1. A Notches/matching edges
- B Stitching line
- C Cutting line
- D Place on fold arrow (4)
2. Number 3 Front view
- Number 4 Back view (2)

3. Seam allowance	(1)
4. The fabric is double ✓ and will be cut right round it to produce two pieces that look alike ✓	(2)
	(10)

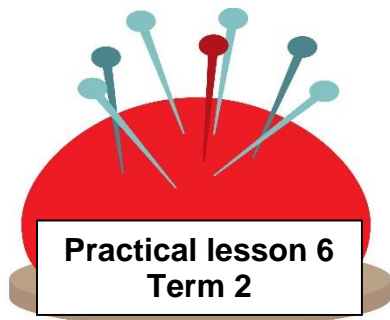

Consumer Studies Clothing or Soft Furnishing Option

The Commercial pattern

Name: _____	Grade 8	
Choose the correct answer from Column B that goes with words in Column A. Write the correct number in the answer block.		
Answer	Column A	Column B
	Lengthwise grain	A. Number of the pattern
	Instruction sheet	B. Back of pattern
	Front of the pattern	C. Grain line
	Back of pattern	D. Sketches of pattern pieces
	Amount of fabric	E. Place on fold
		F. Notches
		G. Sketches of back views
(5)		
2. Describe the meaning of the following pattern markings:		
2.1	Notches: _____	
2.2	Cutting line: _____	
2.3	Grainline: _____	

2.4	Place on fold: _____	
2.5	Seam allowance: _____	
		(5)
3.	Lay out the pattern pieces in the correct way.	
3.1	Cut out the pattern pieces from the pattern sheet	(2)
3.2	Lay out the pattern pieces on the fabric:	
	• Grainline	(4)
	• Place on fold	(3)
3.3	Paste the pattern pieces on the fabric.	(1)
		(10)

Total= 20

Term: 2	CONSUMER STUDIES Grade 8 –Clothing or Soft Furnishing Option
---------	---

**Seams: Open single seam
Closed single seam**

A seam is formed when two pieces of fabric are stitched together. The space between the side of the fabric and the sewing line, is the seam allowance. Most machine have a 15mm / 5/8 inch guideline etched onto the throat-plate. The seam allowance can be finished off with zigzag stitch, overlocking or a narrow edge stitching.

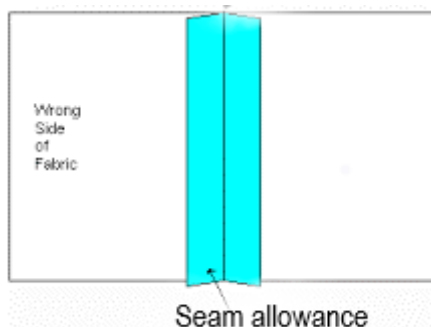

There are different types of seams, namely the open single seam, the closed single seam and the enclosed single seam.

1. The Open single seam

- Pin **two** pieces of fabric, right sides together - raw edges and pattern markings matching. You can tack the pieces together before stitching on the machine.
- Stich on the **stitching line**, 15mm from the side. Use the guideline on the throat-plate of the machine.
- Press the seam allowances **open**.
- Each side of the seam allowance is finished off **separately**.
- You can use any of the following methods to end off the seam allowance.

Examples of how the seam allowances can be finished off:

Zigzag stitches	Pinking shears	Overlocking	Edge stitching

2. The Closed single seam

- Pin **two** pieces of fabric, right sides together - raw edges and pattern markings matching. You can tack the pieces together before stitching on the machine.
- Stich on the **stitching line**, 15mm from the side. Use the guideline on the throat-plate of the machine.
- Finish off the seam allowances **together**.
- Press the seam allowances to **one side**.



CLASS ACTIVITY

GRADE 8 TERM 2

Follow the instructions and work the seam on your own

WORKING AN OPEN SEAM

<https://www.youtube.com/watch?v=CBz4HFt-VFw>

WORKING A CLOSED SINGLE SEAM

<https://youtu.be/YrXto0ExPol>

Closed single seam		
Pin RS facing Stitch - 15 mm wide	5	
Stitching – straight	5	
Press to one side	5	
Zig zag	5	
	20	

Open single seam		
Pin – RS facing stitch - 15 mm wide	5	
Stitching - straight	5	
Press open	5	
Zig zag	5	
		20

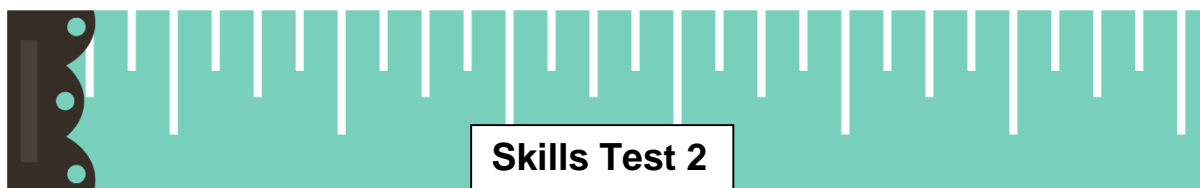

CONSUMER STUDIES: Grade 8	OPTION: Clothing / Soft furnishing / Patchwork
Skills Test 2 - Term 2	Seams - 20

Name:	Grade 8
--------------	----------------

TASK: Seams on article: Make an open/plain seam Make a closed single seam
--

<p>Assessment criteria 0 Unacceptable, does not meet the criteria 1 – Poor, meet some criteria 2 – Average, meets most criteria 3 – Good, meets all the requirements 4 – Excellent, exceeds all requirements</p>
--

DATE	EVALUATION	MARK	REMARKS
	Open single seam Pin – RS facing stitch - 15 mm wide Stitching - straight Press open Zig zag / Overlock	5 5 5 5 <hr/> 20	
	Closed single seam Pin – RS facing stitch - 15 mm wide Stitching – straight Press to one side Zig zag / Overlock	5 5 5 5 <hr/> 20	
		40 ÷ 2 =20	

Consumer Studies
Clothing or Soft Furnishing Option
Grade 8

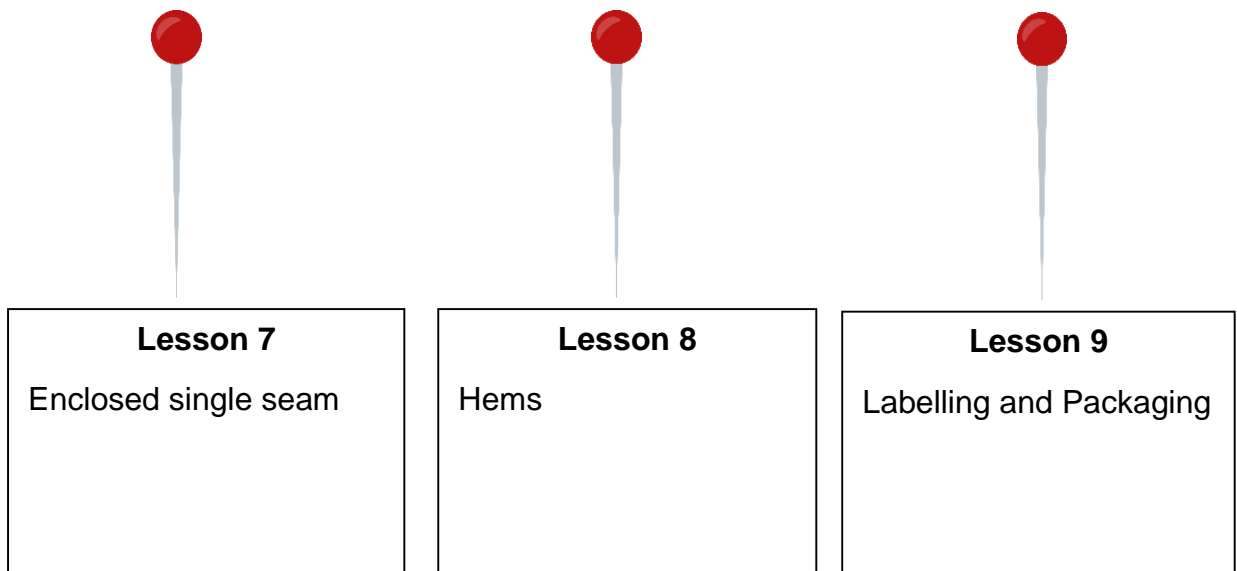
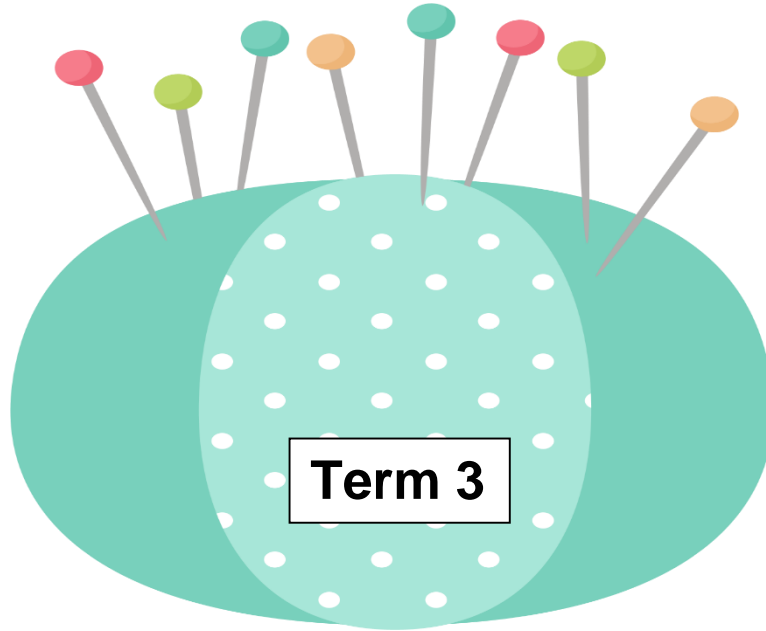

Consumer studies: Clothing or Soft Furnishing

Grade 8 - Practical lessons - Term 3

Term: 3 Practical lesson	Seams: The Enclosed single seam
<p style="text-align: center;">Seams</p> <ol style="list-style-type: none">1. Open single seam - recap2. Closed single seam – recap3. The enclosed single seam:<ul style="list-style-type: none">• Pin two pieces of fabric, right sides together - raw edges and pattern markings matching. You can tack the pieces together before stitching on the machine.• Stich on the stitching line, 15mm from the side. Use the guideline on the throat-plate of the machine.• The seam allowances are graded, snipped and clipped to ensure that it will lie flat when it is folded between the two layers of fabric.• The seam allowances are not over locked.• This seam is not visible, it is folded between two layers of fabric. For example, the seam inside a facing, waistband, pocket or collar.4. The shaped facing<p>A shaped facing can also be used by the waist line of a skirt or pants.</p><ul style="list-style-type: none">• The shaped facing prevents the seam from fraying and add to the neatness of the garment.• The shaped facing is only visible on the wrong side of the garment.• The facings has the same shape and size as the waistline of the garment.• Facings are made from the same fabric as the garment.• Inter facing are ironed onto the facing to make it stiff.• The shaped facing are sewn onto the garment with an enclosed single seam	

Grading of seam allowances to reduce bulk when turning right sides out

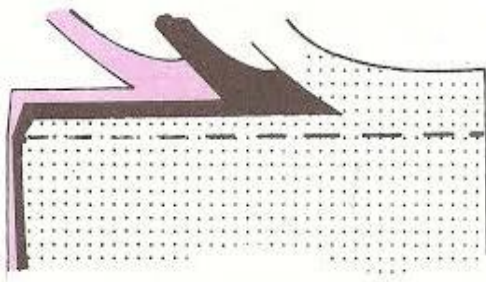

Snip corners to reduce bulk when turning right sides out

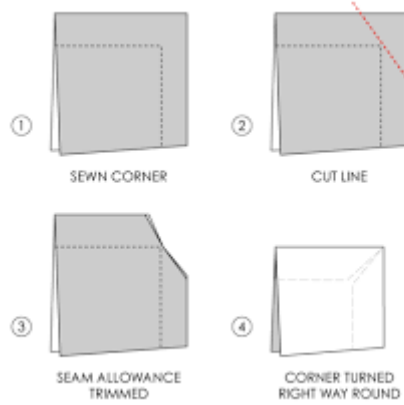

Snip and clip rounded seams to reduce bulk when turning right sides out

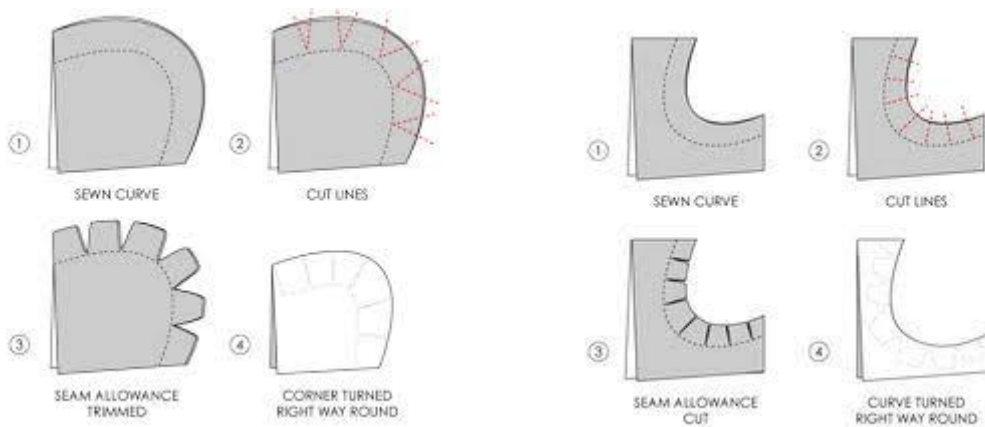

CLASS ACTIVITY RECAP		GRADE 8 TERM 3
Follow the instructions and work the seam on your own		
WORKING AN OPEN SEAM		
https://www.youtube.com/watch?v=CBz4HFt-VFw		
WORKING A CLOSED SINGLE SEAM		
https://youtu.be/YrXto0ExPol		
Closed single seam Pin – RS facing stitch - 15 mm wide Stitching – straight Press to one side Zig zag	5 5 5 5 <hr/> 20	
Open single seam Pin – RS facing stitch - 15 mm wide Stitching - straight Press open Zig zag	5 5 5 5 <hr/> 20	



Consumer Studies

Clothing or Soft Furnishing Option

Seams: Enclosed single seam on a sampler

Name:	Grade 8
TASK: Complete the worksheet and sampler	20

Use two 15cm x 15cm swatches of fabric to make a sampler of an enclosed single seam with a corner.

Pin right sides together. Sew two sides to form a corner.

Grade and clip the seam allowances. **(20)**

<p>Assessment criteria</p> <p>0 - Unacceptable, does not meet the criteria</p> <p>1 - Poor, meet some criteria</p> <p>2 - Average, meets most criteria</p> <p>3 Good, meets all the requirements</p> <p>4- Excellent, exceeds all requirements</p>

EVALUATION	MARK	REMARKS
Enclosed single seam on swatch		
Pin – RS together	5	
Stitch - 15 mm wide around two sides to form a corner	5	
Grade seam allowance	5	
Snip corner of seam allowance	5	
	20	

Total = 20

Consumer Studies Grade 8	Option: Clothing / Soft furnishing
Term 3 Practical lesson	Hems
Hems	

A hem is a finishing that is used on the bottom edge of an article. It can be the hem of clothing, curtains, table cloths, the edge of a ruffle, etc.

1.1 The width of the hem:

The width of the hem will be determined by the type of article.

1.1.1 Wide hems are used on:

- **narrow** and **tight fitting** garments, for example pencil skirt and tight fitting dresses
- curtains

1.1.2 Narrow hems are used on:

- wide garments, for example a wide dress or skirt
- bed and table linen
- blouses
- lingerie (underwear)

1.2 Methods to sew in hems:

1.2.1 Hand sewn hems:

- **Blind-hemstitch** is used to hold the hem securely in place. It should be **almost invisible** on the **right** side of the garment. Used on thick fabric and smart clothes, e.g. coats, jackets and pencil skirts.

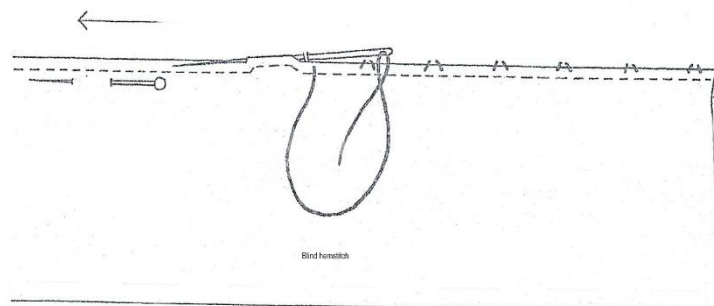

- **Hemstitches** are small, strong stitch sewn on the wrong side of the garment, and **shows on the right side** of the garment.

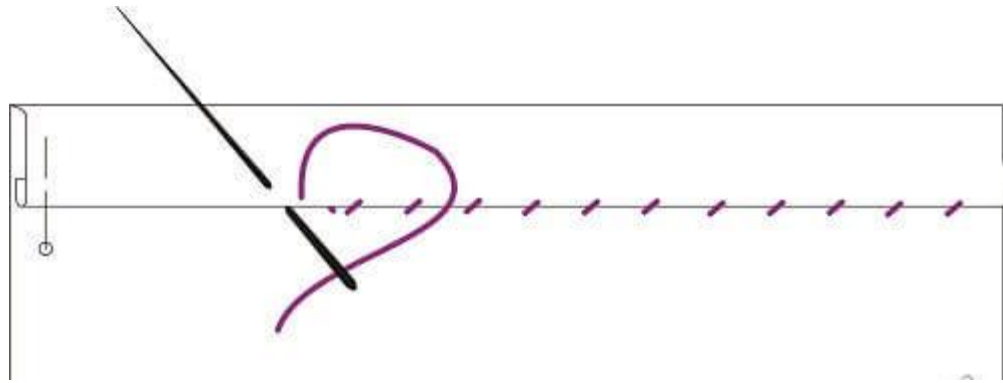

1.2.2 Machine sewn hems:

- **Narrow** hems are sewn in with the sewing machine, for example hems in blouses, shirts, underwear, pajamas and aprons.



CLASS ACTIVITY	HEMS	GRADE 8 TERM
3		

1. Give the type of hems illustrated in diagram A and diagram B

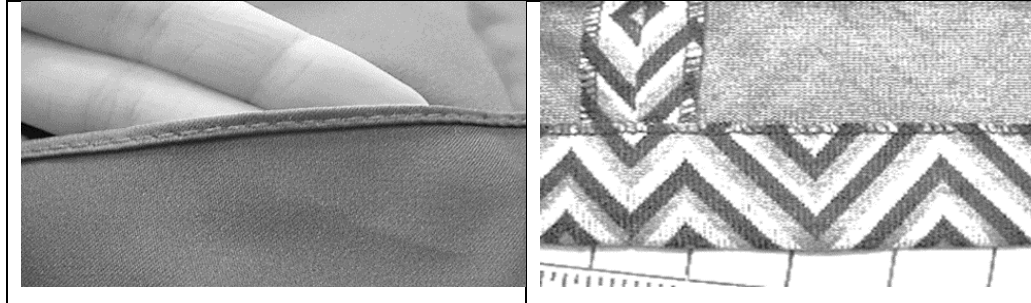

A

B

(2)



2. Explain the function of hems

(2)

3. Match the method of holding down each of the hems below. Pick the method from the methods given.

Machine sewn hem, Close hem stitches, Blind hem stitch, Herring bone held hem, False hem,

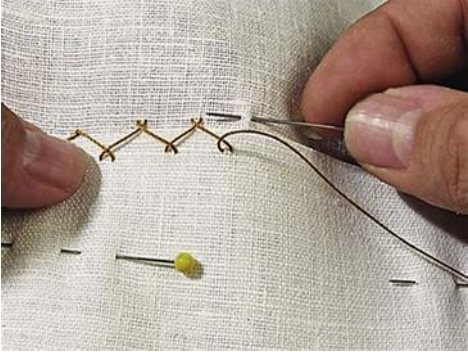
3.1			
3.2			

3.3			
3.4			
3.5			

(5)
Total (9)

CLASS ACTIVITY	HEMS	GRADE 8 TERM
3		
Marking guidelines		
1. A narrow hem		
B wide hem		(2)
2. A hem is a finishing that is used on the bottom edge of an article		(2)
3.1 close hem stitch		
3.2 slip/blind hem stitch		
3.3 Herringbone held hem		
3.4 Machine stitched hem		
3.5 Blind-machine stitched hem		(5)
Total		(9)



Consumer Studies

Clothing or Soft Furnishing Option

Hems

Name:		Grade 8	
TASK:	<p>Make a sampler of a hem.</p> <ul style="list-style-type: none"> - Use a 15cm x 15cm fabric swatch. - On the one end, fold over 1cm and tack. - Sew an edge stitching. - Fold a hem of 3 cm wide. Pin and tack in place. - Sew hem with blind hemstitch. 		
<table border="1" style="margin-left: auto; margin-right: auto; border-collapse: collapse;"> <tr> <td style="padding: 5px;"> <p>Assessment criteria</p> <p>0 - Unacceptable, does not meet the criteria</p> <p>1 - Poor, meet some criteria</p> <p>2 - Average, meets most criteria</p> <p>3 - Good, meets all the requirements</p> <p>4 - Excellent, exceeds all requirements</p> </td> </tr> </table>			<p>Assessment criteria</p> <p>0 - Unacceptable, does not meet the criteria</p> <p>1 - Poor, meet some criteria</p> <p>2 - Average, meets most criteria</p> <p>3 - Good, meets all the requirements</p> <p>4 - Excellent, exceeds all requirements</p>
<p>Assessment criteria</p> <p>0 - Unacceptable, does not meet the criteria</p> <p>1 - Poor, meet some criteria</p> <p>2 - Average, meets most criteria</p> <p>3 - Good, meets all the requirements</p> <p>4 - Excellent, exceeds all requirements</p>			
EVALUATION	MARK	REMARKS	
<p>Wide hem sewn with blind hemstitch:</p> <p>To start: Fold edge over – 1cm wide - Pin and tack - sew an edge stitching.</p> <p>Fold hem – 3cm wide tack in place</p> <p>Start and end blind hemstitch</p> <p>Sew blind hemstitch</p> <p>Neatness of stitches on RS</p>	<p>5</p> <p>5</p> <p>5</p> <p>5</p> <hr style="width: 20%; margin: 0 auto;"/> <p>20</p>		

Total = 20



Consumer Studies

Clothing or Soft Furnishing Option

Packaging and Labelling



Grade 8
Term: 3
Practical lesson: 9

Packaging and Labelling

9. Packaging and Labelling

9.1 Packaging

Packaging protects the product and is designed to attract the attention of the consumer. It is designed to be easily displayed, handled and opened.

The packaging of some clothing products can be resealed after opening.

Different types of packaging can be used to persuade customers to buy a product.

9.1.1 Reasons for packaging:

- Improve Appearance & Hygiene because attractive products attract attention and will be chosen over another.
- Protect from damage e.g. Airtight package that prevent product from getting dirty.
- Improve handling and is therefore easier to transport and store
- Help to advertise the product because it helps: create market, cultivate loyalty and ensure quality.
- Contains a label that provides information on care and use.

9.1.2 Important factors to consider when choosing packaging:

- Be minimal - just enough to cover the product.
- Must be safe and hygienic.
- Be attractive and economical, preferably transparent.

- Suitable for product type & target market.
- Strong enough to protect product.
- Be user-friendly and provide information.
- Label must be clearly legible.
- Eco-friendly, preferably biodegradable / reusable / recyclable
- Don't mislead consumers (in terms of size, etc.)

9.2 Labelling

Two main functions of labels

9.2.1 To provide information to users

9.2.2 To advertise product

9.2.1 To provide information to users:

It is very important for us to know how to take care of our clothes / soft furnishing articles properly. There are labels inside garments/ soft furnishing articles with instructions on how to care for the item.

What information is displayed on labels?





- The name of the manufacture
- The fibre contents
- The size
- The care symbols



Care symbols:

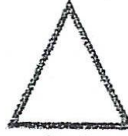

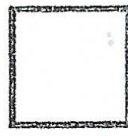
These are important symbols that tell you how to care for your textile items. It is important to follow the care instructions to prevent garments / articles from being damage by the wrong treatment.

The following labelling codes are used throughout the world:



				
WASH	BLEACH	IRONING	DRYING	DRY-CLEANING

Examples of care instructions:

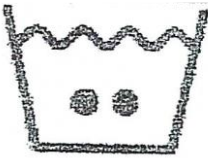
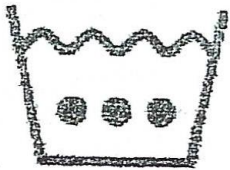
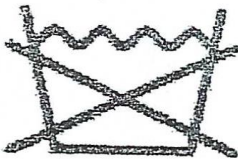

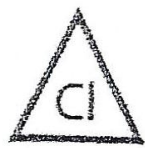

WASH

	
Hand wash only	
	
Wash in lukewarm water (40 °C). For example, wool and synthetic fibres.	Wash in warm water (60 °C). For example, coloured cotton material
	
Wash in very hot water (95 °C). for example, white cotton material.	Do not wash



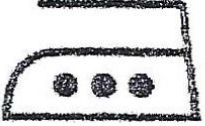

BLEACHING

	
You can use Jik to bleach this garment	Do not bleach with Jik



IRONING

 <p>Iron with cool iron, for example acrylics, nylon and polyester</p>	 <p>Iron with a warm iron, for example polyester blends and wool blends</p>
 <p>Iron with a very hot iron for example, cotton and linen.</p>	 <p>Do not iron</p>

DRYING

 <p>Hang on line</p>	 <p>Drip-dry</p>	 <p>Dry on flat surface</p>
 <p>Tumble-dry</p>	 <p>Do not tumble-dry</p>	

DRY-CLEANING

 <p>Clothes can be dry-clean</p>	 <p>Do not dry-clean</p>
---	---

9.2.2 To advertise the product:

Important factors for labels and advertisements used as

Marketing tools:

- Place/ contact details must be given/ indicated.
- It must be creative and eye catching.
- The layout simple and the message must be clear and understandable, it must not be to “busy” or require too much reading.

- The product clearly stated or shown by a suitable illustration.
- Price must be included.
- Trade name must be given.
- There MAY NOT BE ANY spelling errors.

Examples of labels:





CLASS ACTIVITY

GRADE 8 TERM

Clothing labels, care symbols and packaging

1. Study the label and analyse it for meeting labelling criteria. Give FOUR points that you agree with



- The name of the manufacture
- The fibre contents
- The size
- The care symbols
- The product name

Any 4

(4)

2.			
TASK:	Design a label for the garment or article		
<table border="1"> <tr> <td> Assessment criteria 0 - Unacceptable, does not meet the criteria 1 - Poor, meet some criteria 2 - Average, meets most criteria 3- Good, meets all the requirements 4 - Excellent, exceeds all requirements </td> </tr> </table>			Assessment criteria 0 - Unacceptable, does not meet the criteria 1 - Poor, meet some criteria 2 - Average, meets most criteria 3- Good, meets all the requirements 4 - Excellent, exceeds all requirements
Assessment criteria 0 - Unacceptable, does not meet the criteria 1 - Poor, meet some criteria 2 - Average, meets most criteria 3- Good, meets all the requirements 4 - Excellent, exceeds all requirements			
EVALUATION	MARK	REMARKS	
Design a label			
Name of manufacturer	2		
Logo / photo of the manufacturer	2		
Size	2		
Care symbols	2		
Creativeness	2		
	10		



Consumer Studies

Clothing or Soft Furnishing Option

Clothing labels, care symbols and packaging

FORMAL ASSESSMENT Consumer Studies	
Practical lesson 9 – Reading a label	
Term 3	TOTAL 20
Name:	Grade 8
1. Study the following label and answer the questions that follow	



A



B



C



D

- 1
- 2

1.1 Give the fibre content of Label A (2)

1.2 Draw the care label to show 'No bleach' on Label A (1)

1.3a) State what the following care symbols mean (2)

a)

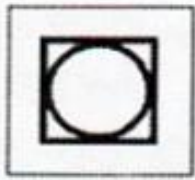

b)



1.4 Give the oldest and youngest age range size as indicated on the Label B (2)

1.5 Would the fabric used to make articles in Label B be suitable to use as an ironing cloth? Motivate your answer. (3)

1.6 Draw the suitable symbols identified by the arrows 1 and 2 in Label C (2)

1.7 Explain what 'dry inside out' means on Label C (1)

1.8 Mention what the names 'Levis' and 'Supreme' stand for on Label D (2)

1.9 Study Label D carefully. Using the information on the labels, predict the type of article 'Supreme' is. Explain the method you used to reach a conclusion. (3)

Describe TWO functions for having such labels on garments (2)





Consumer Studies

Clothing or Soft Furnishing Option

Clothing labels, care symbols and packaging

FORMAL ASSESSMENT Consumer Studies	
Practical lesson 9 – Reading a label	
Term 3	TOTAL 25
Name:	Grade 8
1. Study the following label and answer the questions that follow	

Reading a label MARKING GUIDELINE	
1.1 Give the fibre content of Label A	(2)
<i>50% cotton 50% polyester</i>	
1.2 Draw the care label to show 'No bleach' on Label A	(1)
	
1.3a) State what the following care symbols mean	(2)
<p style="text-align: center;"><i>a) Tumble dry b) drip dry</i></p>	
1.4 Give the oldest and youngest age range size as indicated on the Label B	(2)
<i>18-24 months and 7 to 8 years</i>	
1.5 Would the fabric used to make articles in Label B be suitable to use as an ironing cloth? Motivate your answer.	(3)
<i>No/It would not be suitable✓</i>	
<i>The fabric would not be suitable because heat is produced by the iron✓ and the care label states that 'keep away from fire✓' / The fabric has to be ironed with a low temperature✓, the care label shows one dot on the iron symbol✓.</i>	
1.6 Draw the suitable symbols identified by the arrows 1 and 2 in Label C	(2)

1.

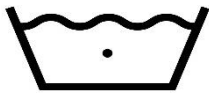

OR



2.



1.7 Explain what 'dry inside out' means on Label C (1)

Turn the article/clothing inside out

1.8 Mention what the names 'Levis' and 'Supreme' stand for on Label D (2)

Brand name/s✓, the name by which the article of clothing is known✓

1.9 Study Label D carefully. Using the information on the labels, predict the type of article 'Supreme' is. Explain the method you used to reach a conclusion. (3)

It is written that it is an article made in China✓ but also gives the name New York City✓ to seem like it is from America/New York City✓. It is confusing people/it is Fong Kong/counterfeit✓
(Any 3)

Describe TWO functions for having such labels on garments (2)

For identifying the company that manufactured the article

They give the size of the clothing item

The type of material the article is made of

They communicate how to care for the article

(Any 2)

Total (20)



Skills Test 3

Name:			Grade 8	
TASK	Seams on article:	Make an enclosed single seam Complete the waistband	20	
<table border="1" style="margin-left: auto; margin-right: auto;"> <tr> <td> Assessment criteria 0 - Unacceptable, does not meet the criteria 1 - Poor, meet some criteria 2 - Average, meets most criteria 3 - Good, meets all the requirements 4 - Excellent, exceeds all requirements </td> </tr> </table>				Assessment criteria 0 - Unacceptable, does not meet the criteria 1 - Poor, meet some criteria 2 - Average, meets most criteria 3 - Good, meets all the requirements 4 - Excellent, exceeds all requirements
Assessment criteria 0 - Unacceptable, does not meet the criteria 1 - Poor, meet some criteria 2 - Average, meets most criteria 3 - Good, meets all the requirements 4 - Excellent, exceeds all requirements				
DATE	EVALUATION	MARK	REMARKS	
	Enclosed single seam – waistband Pin – RS facing stitch - 15 mm wide Stitching - straight Grade seam allowance Snip/clip seam allowance	5 5 5 5 <hr style="width: 20%; margin-left: auto; margin-right: 0;"/> 20		
	Complete waistband / band Fold 15mm in on raw side Tack the folded edge Top Stitching on band – straight Press	5 5 5 5 <hr style="width: 20%; margin-left: auto; margin-right: 0;"/> 20		
		40 ÷ 2 =20		

Skills Test = 20

Name:		Grade 8 Term 4	
TASK	PROJECT BASED LEARNING	POP UP STALL	20 marks

PROJECT BASED LEARNING

Plan a “Pop up Stall”

People was so impressed with the product you made for the skills test in term 3, that you decided to make more of the same item and to sell it.

Plan a “Pop up Stall” for a Market Day at your school where your class will be selling handmade items like;

Children’s clothing, clothes to fit in simple styles, aprons etc for **Clothing Option** or bags, poaches, oven gloves, placemats, table runners, pillow cases etc for **Soft Furnishing Option**

Ensure that people become aware of the product you need to market it to the local community on social media.

Use the following steps to help you with your marketing strategy:

1. List THREE resources you need, apart from the product you will be selling. (3)
2. Describe what you would do to ensure that people prefer your stall. (2)
3. Explain the importance of greeting and serving customers. (2)
4. Choose a creative, suitable trade name for your potential business. (2)
5. Invent a logo/slogan that is suitable for your business and that would attract potential new customers (2)
6. Design yourself a creative, attractive label that will fit the image of your product and will draw the attention of your target market. Make a real label that you attach to the item, in other words the label needs to be the correct size and must include the needed detail to serve as a marketing tool for your product. For example, you need to include your trade name, logo, address/contact details, and the price. (4)
7. Develop a full-A4 page, colourful advertisement suitable for social media (5)

PROJECT BASE LEARNING

MARKING GUIDELINE

1. List 3 resources you need, apart from the product you will be selling.

Any THREE:

- Money (change)
- Table (fold-up)
- Table cloth

- Chairs
 - Decorations
 - Gazebo
- (3)

2. Describe what you would do to ensure that people prefer your stall.
Learners can give any example that shows creativity / ingenuity.
For example:

- Free tasting samples
 - Diverse payment options (card facilities)
 - Competition / Give-aways
 - Entertainment
 - Service with a smile
- Any 2 (2)

3. Explain the importance of greeting and serving customers.

- Be polite and friendly (smile)
 - Be respectful
 - Make eye contact
 - Acknowledge the customer immediately
- Body language **Any three:** (2)

4. Suitable trade name for business✓, relevant to product✓ and target market✓ and creative✓ (2)

5. Suitable logo / slogan that will capture customers' interest✓ is suitable for the product✓ and that is creative, short and sweet✓ (2)

6. Label for product:

- Design creative, attractive and draws attention✓
- Loose label with correct size (as per instruction) ✓
- All named information appear on label: trade name✓, logo / slogan✓ Price✓ address / contact details✓ any suitable answer (any 4) (4)

7. Advertisement criteria:

- Different colours used / colourful (1)
 - Suitable for social media (1)
 - Adhered to the following criteria
 - * Place/ contact details given/ indicated ✓
 - * Creative and eye catching✓
 - * Layout simple, message clear and understandable✓
 - * Product clearly stated✓
 - * Suitable illustration✓
 - * Price included✓
 - * Trade name given✓
 - * NO spelling errors in advertisement ✓ Any 3 (3)
- (5)

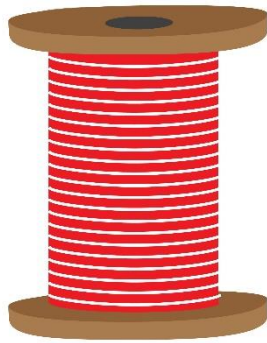

Examples of Articles that can be made by using the basic needlework equipment and a sewing machine.

The practical lessons are the minimum practical lessons required for assessment. After completion of these lessons more lessons can be done for drilling of techniques or as incentives.

The practical skills that were developed in the practical lessons are applied to practical items for selling.

Soft Furnishing: Examples such as: bags, poaches, oven gloves, placemats, table runners, pillow cases etc. can be selected.

Clothing: Examples such as children's clothing, clothes to fit in simple styles, aprons that cater for a variety of skills they need to learn can be selected

Choose articles that shows progression from Grade 8 to Year 4.

New techniques are introduced namely disposal of fullness, fasteners and a shaped facing.

Look for articles that go with the current fashion trends. It will make learners excited to learn new skills. The focus is on machine stitching and entrepreneurship.

Make use of **Pinterest** to find interesting ideas.

The procedure followed for the application is illustrated in the examples below:

A small article can be made to get the learners confidence. Use your own imagination and the help of Pinterest to find an article that can be marketable, e.g. toiletry bag, earphone poach, glasses case, cell phone poach, etc.

Start with the garment / soft furnishing article

In **Year 3** it is possible to combine the different modules when choosing articles to make. Learners can make a bag or a pillow which includes patchwork/embroidery and then a garment to include all the prescribed techniques. By making a variety of articles, the learners won't get bored. It will also provide them with more ideas to use once they explore their entrepreneurial skills.

If you would like to include patchwork in the bag, make use of tutorials to broaden your scope of methods to use. It is a very good way for learners to hone their sewing skills.

There are many different ways to use straight strips or squares as the starting point. Very interesting patterns can be formed.

EXAMPLES OF SOFT FURNISHING ITEMS

a simple cushion cover



Power point presentation on making a cushion

Sunglass pouch



Oven gloves

Pot holders/Place mats



Pencil case

Bags

This size of the bag should fit most sunglasses. If yours are larger than normal, wrap a piece of fabric around them and see how much width you need. If it's more than 15.5cm you'll need to increase the size of the pouch.

DIY Easy Drawstring Sunglasses Case



SUPPLIES REQUIRED:

1 pieces fabric 17.cm x 20cm

1 piece ribbon or bias tape, cut 36cm long

Needle and thread

pins

Safety Pin

INSTRUCTIONS:



Step 1: Finish fabric edges. Fold fabric lengthwise, right sides together. (Folded size is 9cm x 24cm) Using disappearing ink pen mark points 3.3 cm and 4 from top on side with raw edges. The section between the markings will be the opening for the drawstring

Step 2: Starting at top edge, stitch to marking, backstitch and cut thread. Start stitching again at next marking 4.5cm from top. Pivot at bottom corner, stitch to folded edge, backstitch and cut threads.



Step 3: Press seams open. Make the top casing. Fold top edge down 3 cm and press. Fold edge in .11cm and press. Pin if needed. Slip stitch casing in place, stitching close to folded edge about 2.2cm from top.

Step 4: Attach one end of ribbon to safety pin. Thread through casing. Knot ends if desired.





Activity for book cover

<https://www.youtube.com/watch?v=A5Ub6KvDe-0>



Basic book cover

EXAMPLES OF CLOTHING ITEMS



Boys bow tie/Girls ribbon

Hair scrungy



Activity 1 pieces.pdf

Pattern and instructions for the test

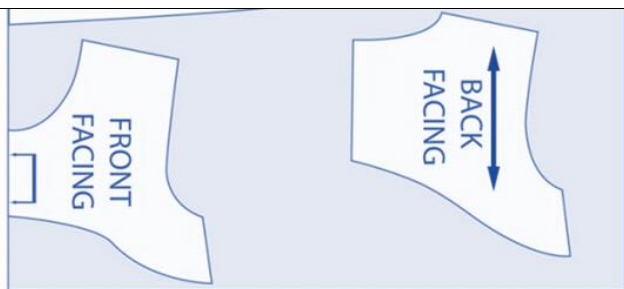

INSTRUCTIONS (increase the pattern proportionally as desired)

1. Cut out pattern pieces for the dress
 2. Lay out the pattern pieces correctly on the fabric following the pattern markings for laying out
 3. Pin and cut out the patterns on the fabric
 4. Transfer pattern markings required for sewing the dress
 5. Layout the front and back facing as shown on interfacing as well
 6. Infuse the interfacing
 7. Join the shoulder seams and side seams of the garment pieces matching edges. Make open seams. Press. Finish of the edges
 8. Join the facings at the shoulder and under arm with open seams. Trim the seam allowance. Edge stitch the free edge
 9. Match the right side of shoulder seams and under arm seams of the facings to the right side of the garment shoulder and under arm seams
 10. Make an enclosed seam around the armholes and neckline
 11. Press open the seams grade and snip and notch curved edges. Turn facing to the wrong side. Press
 12. Hold down the facing at the under arm seam to secure in place
 13. Fold the edge of the garment then turn in hem. Hold down with slip stitch
 14. Fast learners can attach a pocket or 2 to their garment
 15. Press garment
- Submit the article for final marking

Kung Fu sleeveless top



<https://www.google.com/url?sa=i&url=https%3A%2F%2Fwww.instructables.com%2F%2FKung-Fu-T-Shirt>