



basic education

Department:
Basic Education
REPUBLIC OF SOUTH AFRICA

**NATIONAL
SENIOR CERTIFICATE**

GRADE 12

CIVIL TECHNOLOGY: CIVIL SERVICES

EXEMPLAR 2018

MARKS: 200

TIME: 3 hours

This question paper consists of 18 pages and 6 answer sheets.

REQUIREMENTS:

1. Drawing instruments
2. A non-programmable calculator
3. ANSWER BOOK

INSTRUCTIONS AND INFORMATION

1. This question paper consists of SIX questions: TWO questions are generic and FOUR questions are subject specific.
2. Answer ALL the questions.
3. Answer each question as a whole. Do NOT separate subsections of questions.
4. Start the answer to EACH question on a NEW page.
5. Do NOT write in the margins of the ANSWER BOOK.
6. You may use sketches to illustrate your answers.
7. Write ALL calculations and answers in the ANSWER BOOK or on the attached ANSWER SHEETS.
8. Use the mark allocation as a guide to the length of your answer.
9. Make drawings and sketches in pencil, fully dimensioned and neatly finished off with descriptive titles and notes to conform to the *SANS/SABS Code of Practice for Building Drawings*.
10. For the purpose of this question paper, the size of a brick should be taken as 220 mm x 110 mm x 75 mm.
11. Use your own discretion where dimensions and/or details have been omitted.
12. Answer QUESTIONS 2.1, 2.2, 3.1, 3.2, 5.6 and 6.10 on the attached ANSWER SHEETS using drawing instruments where necessary.
13. Write your CENTRE NUMBER and EXAMINATION NUMBER on every ANSWER SHEET and hand them in with your ANSWER BOOK, whether you have used them or not.
14. Due to electronic transfer, drawings in the question paper are NOT to scale.
15. Google images was used as source for all photographs and pictures.

QUESTION 1: OHSA, MATERIALS, TOOLS, EQUIPMENT AND JOINING (GENERIC)

Start this question on a NEW page.

- 1.1 Choose a description from COLUMN B that matches an item in COLUMN A. Write only the letter (A–L) next to the question numbers (1.1.1 to 1.1.10) in the ANSWER BOOK, e.g. 1.1.11 M.

COLUMN A		COLUMN B	
1.1.1	Curing	A	used by only one person at a time
1.1.2	Ladder	B	corrosion proof
1.1.3	Builder's hoist	C	applied to the base metal – makes the metal corrosion resistant
1.1.4	Zinc coating	D	temporary structure that allows workmen to work comfortably above chest height
1.1.5	Scaffold	E	quick method of transferring tools and equipment between floors
1.1.6	Chute	F	metal dipped in molten zinc
1.1.7	Electroplating	G	can be applied with a brush
1.1.8	Paint	H	process of keeping freshly cast concrete moist for a specific period
1.1.9	Aluminium	I	process of coating a metal with a thin layer of another metal by electrolysis
1.1.10	Galvanised	J	quick method of sending rubble and debris to ground floor
		K	can be applied in powder form
		L	prevent splashing of chemicals

(10 x 1)

(10)

1.2 FIGURE 1.2 below shows a surveying tool used on a construction site

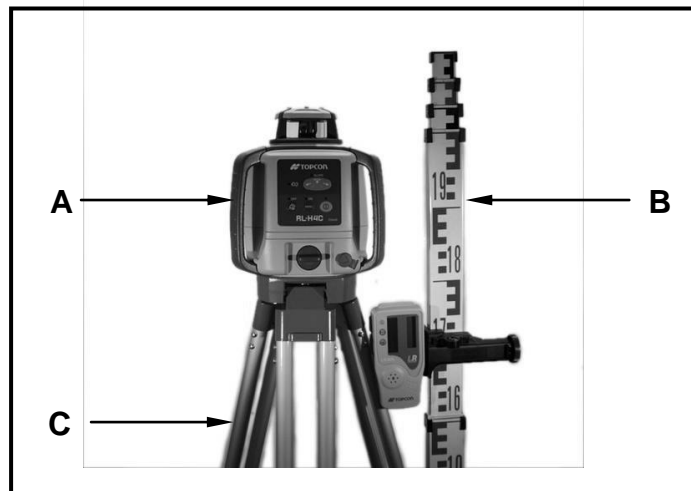

FIGURE 1.2

1.2.1 Identify parts **A–C**. (3)

1.2.2 Explain how will you take care of part **A**. (1)

1.3 FIGURE 1.3 below shows a scaffold with a working platform.

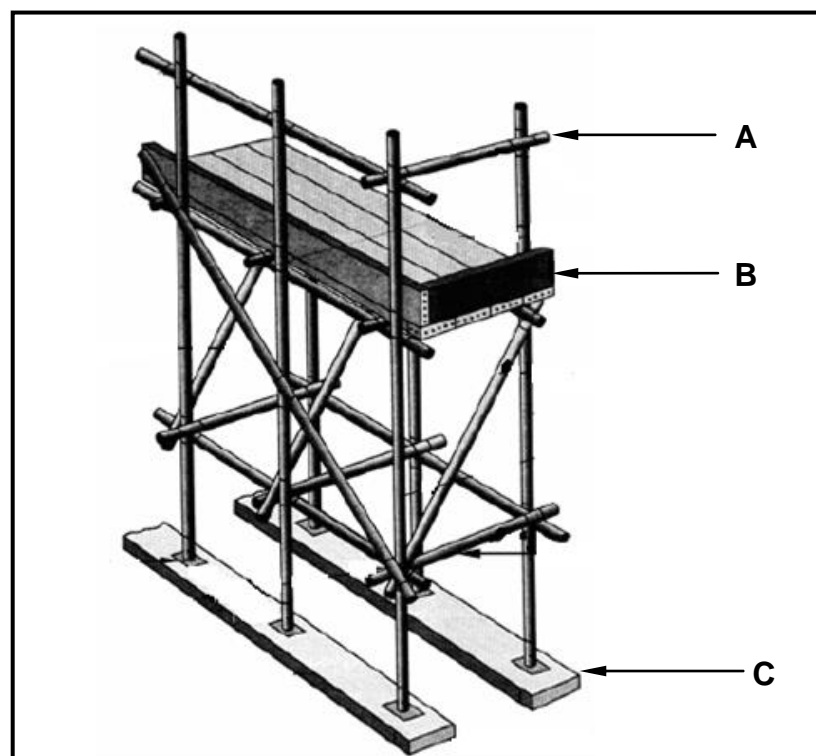

FIGURE 1.3

1.3.1 Describe TWO safety precautions that you will take when working on a scaffold. (2)

1.3.2 Explain the purpose of part **A** in terms of safety. (1)

- 1.3.3 What safety feature does **B** provide? (1)
- 1.3.4 Explain what will happen if part **C** is omitted when workers are working on the platform. (1)
- 1.4 FIGURE 1.4 below shows two pipes with flanges. Recommend a suitable fastener to join the two flanges.

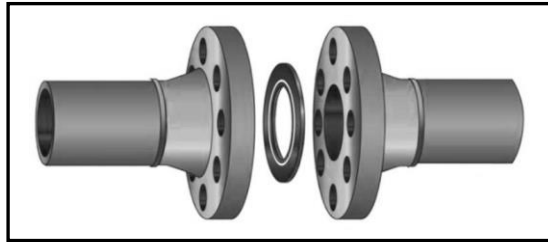

FIGURE 1.4

(1)
[20]

QUESTION 2: GRAPHICS AS METHOD OF COMMUNICATION (GENERIC)

Start this question on a NEW page.

2.1 FIGURE 2.1 below shows different drawings that appear on a building plan. Analyse the drawings and complete the table on ANSWER SHEET 2.1.

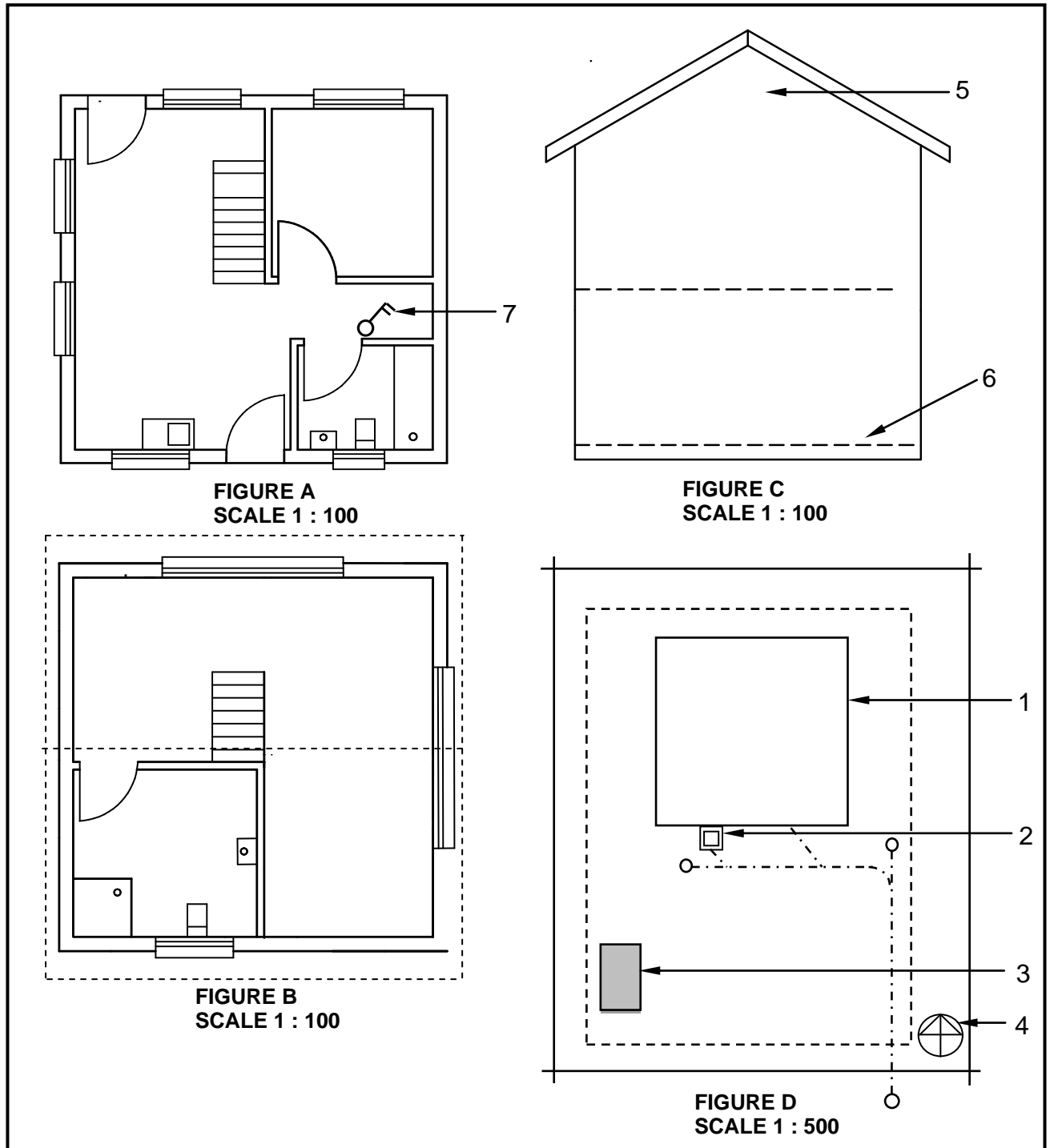

FIGURE 2.1

2.2 FIGURE 2.2 below shows an incomplete floor plan of a proposed dwelling.

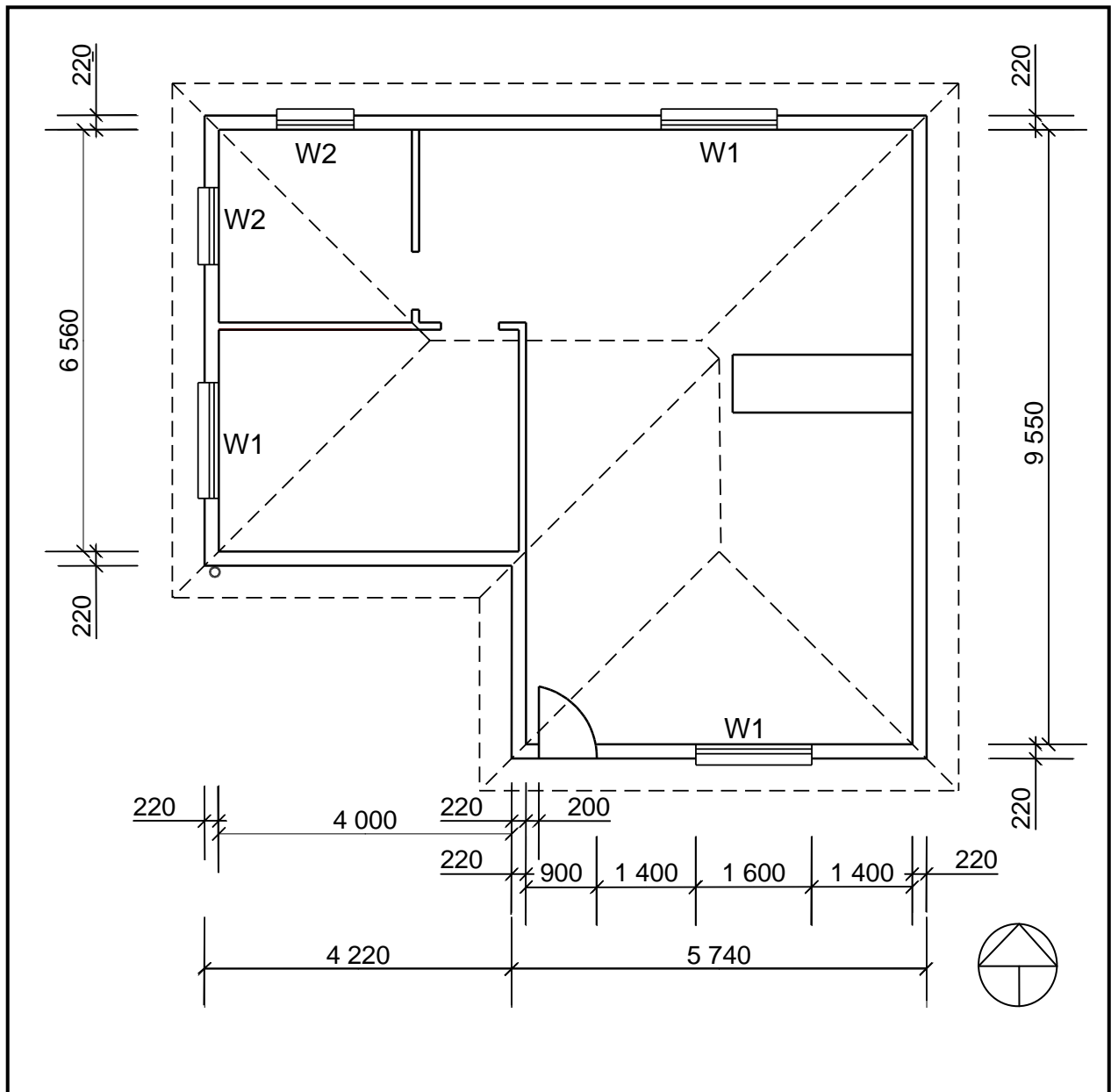

FIGURE 2.2

Study FIGURE 2.2 and develop and draw, on ANSWER SHEET 2.2, to scale 1 : 50, the SOUTH ELEVATION of the building. Use the following specifications. (Use the assessment criteria on ANSWER SHEET 2.2 as a guideline for your drawing.)

SPECIFICATIONS:

- The height between the natural ground level and the top level of the floor slab is 500 mm.
- The height between the floor slab and the underside of the wall plate is 2 600 mm.
- The roof is covered with corrugated galvanised sheeting and is finished with 220 mm wide fascia boards.
- Ridge capping is 100 mm high.

- Rainwater downpipes are 75 mm in diameter and 100 mm square gutters are used.
- A rainwater downpipe should be placed at the corner of the building, as indicated on the floor plan.
- The eaves overhang is 500 mm.
- The door opening is 2 100 mm high and 900 mm wide.
- The door step is 250 mm high.
- The building has a gable roof with a pitch of 30°.

The following must also be shown on the drawing:

- The method used to determine the roof height
- Window sills
- ONE rainwater downpipe

Windows and doors:

WINDOWS AND DOORS	WIDTH	HEIGHT
Window 1 (W1)	1 600	1 200
Door openings 1 (D1)	900	2 100

THREE marks will be allocated for the application of the scale.

Start the drawing from corner **A**, as indicated in the bottom left-hand corner of ANSWER SHEET 2.2.

(25)
[40]

QUESTION 3: CONSTRUCTION ASSOCIATED WITH CIVIL SERVICES (SPECIFIC)

Start this question on a NEW page.

- 3.1 FIGURE 3.1 below shows the front elevation of a brick wall. Study the drawing and answer the questions that follow.

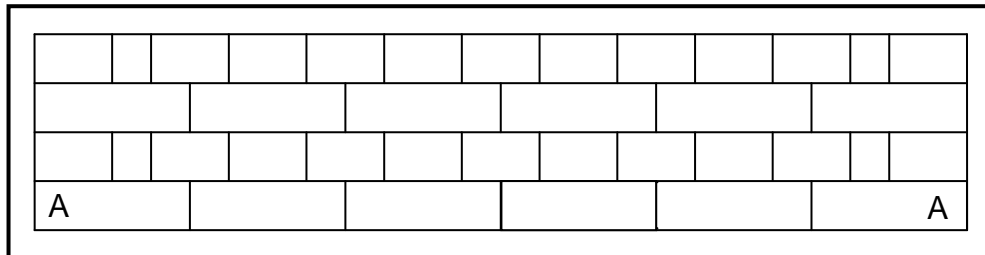

FIGURE 3.1

- 3.1.1 Identify the bond used to build the wall. (1)
- 3.1.2 If the size of ONE brick used in FIGURE 3.1 is 220 x 110 x 75 mm, calculate the total height and length of this brick wall. (4)
- 3.1.3 Use ANSWER SHEET 3.1 to project and draw the end view of this wall. (2)
- 3.1.4 Use ANSWER SHEET 3.1 and project and draw, from the given front elevation, the top view of the course of AA. (2)
- 3.2 FIGURE 3.2 below is an illustration of an isometric view of a manhole. Study the illustration and answer the questions that follow.

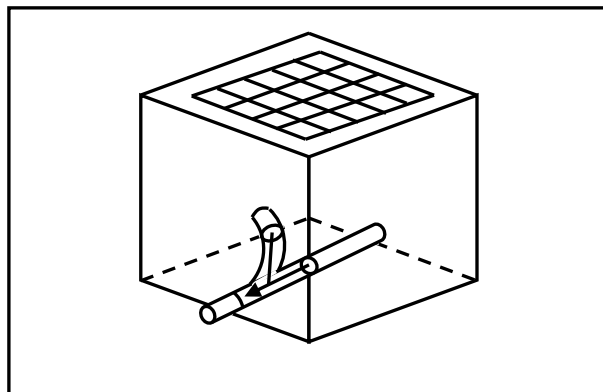

FIGURE 3.2

- 3.2.1 Use ANSWER SHEET 3.2 and complete the drawing of the top view of the manhole without the cover on. Show ALL the hidden detail. (7)
- 3.2.2 What is the minimum depth of a manhole? (1)
- 3.2.3 Name TWO locations on a site where manholes must be placed. (2)
- 3.3 During excavations safety must be a high priority because many accidents can occur. Describe TWO regulations that must be adhered to when excavating. (2)

- 3.4 FIGURE 3.4 below shows the side elevation of shoring for wet or loose soil in a trench. Study the drawing and answer the questions that follow.

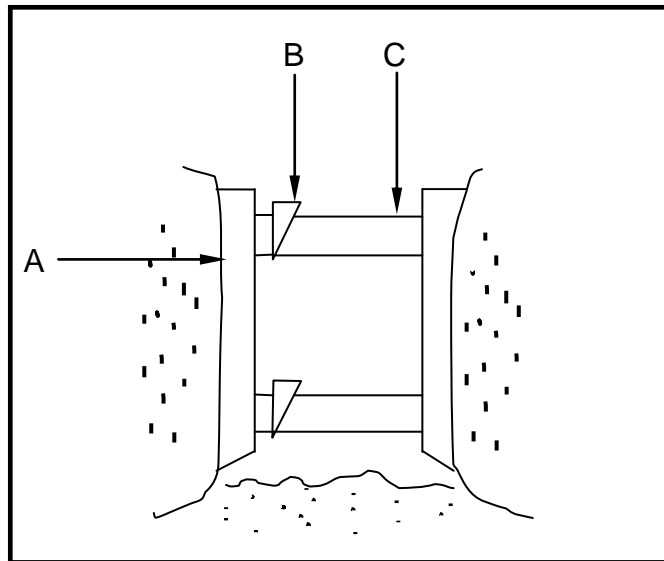

FIGURE 3.4

- 3.4.1 Identify **A**. (1)
- 3.4.2 Explain the function of **B**. (1)
- 3.4.3 Recommend ONE material that can be used for part **A**. (1)
- 3.4.4 Describe TWO important procedures that must be followed when marking out a trench. (2)
- 3.5 Differentiate between *backfill* and *compaction* in terms of the soil on a building site. (2)
- 3.6 State the required slope (gradient) for the following sewerage pipe diameters:
- 3.6.1 Ø 100 mm sewerage pipe (1)
- 3.6.2 Ø 160 mm sewerage pipe (1)
- [30]**

QUESTION 4: COLD AND HOT-WATER SUPPLY (SPECIFIC)

Start this question on a NEW page.

- 4.1 Various options are provided as possible answers to the following questions. Choose the answer and write only the letter (A–D) next to the question numbers (4.6.1 to 4.6.7) in the ANSWER BOOK, e.g. 4.6.8 C.
- 4.1.1 When joining copper pipes with the capillary method, you will ... the two pipes together. (1)
- A weld
 - B solder
 - C glue
 - D tape
- 4.1.2 You can join ... pipes with glue. (1)
- A PVC
 - B copper and PVC
 - C copper and galvanised
 - D copper, PVC and galvanised
- 4.1.3 To join pipes in straight lengths you will use ... (1)
- A straight pipes.
 - B T-junctions.
 - C straight couplings.
 - D straight pan collars.
- 4.1.4 A compression joint may be used to join ... pipes. (1)
- A copper
 - B PVC
 - C galvanised
 - D All the above-mentioned
- 4.1.5 A ... coupling is used to join two galvanised pipes together. (1)
- A Johnson
 - B slip
 - C spigot and socket
 - D None of the above-mentioned
- 4.1.6 ... may be used to join polyethylene pipes. (1)
- A Wood glue
 - B Insulation tape
 - C Contact glue
 - D PVC weld solvent

4.1.7 The pipework that leads to the geyser must be made from ...

- A copper
- B galvanised steel
- C Polycop
- D All the above-mentioned

(1)

4.2 Identify the following symbols used in hot-water systems:

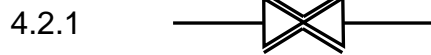

(1)

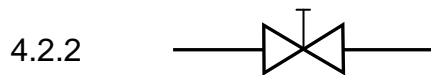

(1)

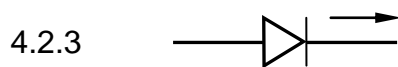

(1)

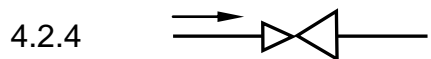

(1)

4.3 FIGURE 4.3 below is a sketch of a horizontally installed high-pressure geyser. Study the illustration and answer the questions that follow.

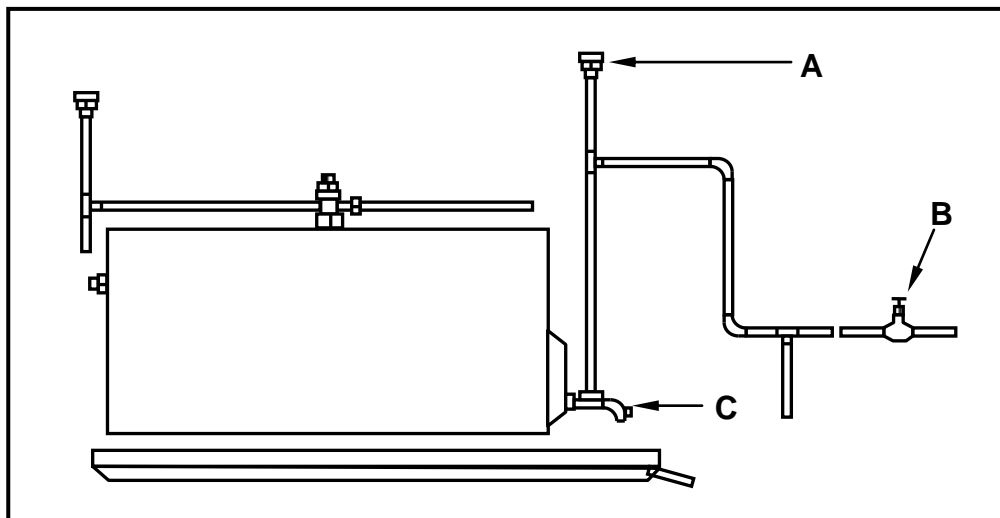

FIGURE 4.3

4.3.1 Explain ONE consequence if vacuum breaker **A** is faulty. (1)

4.3.2 Recommend ONE type of metal tap that you would install at **B**. (1)

4.3.3 Identify **C**. (1)

4.3.4 Name ONE other system that can provide hot water without using electricity. (1)

4.3.5 Explain TWO advantages of using a heat pump to obtain hot water. (2)

4.3.6 Describe TWO reasons why there may be poor hot-water pressure in a domestic home. (2)

- 4.4 Differentiate between FIGURE A and FIGURE B in terms of the flow direction of the water.



FIGURE A



FIGURE B

(2)

- 4.5 FIGURE A and FIGURE B below show two different types of taps.



FIGURE A



FIGURE B

- 4.5.1 Identify the taps in FIGURES A and B. (2)
- 4.5.2 Explain where you would install the taps in FIGURES A and B. (2)

4.6 FIGURE 4.6 below is a sketch of a component used in a cistern.

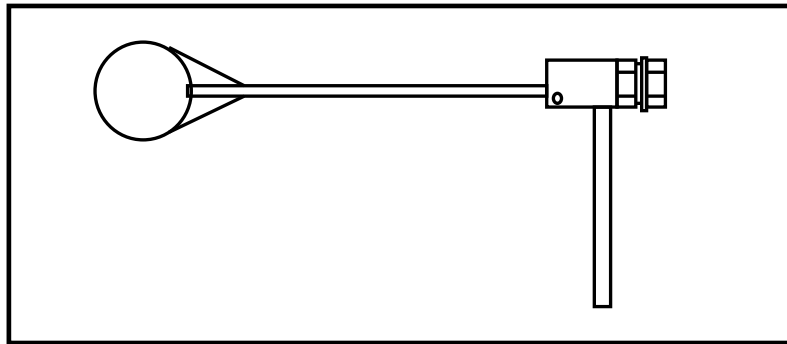

FIGURE 4.6

- 4.6.1 Identify the item in FIGURE 4.6. (1)
- 4.6.2 Explain the function of this item inside the cistern. (1)
- 4.6.3 Name ONE type of material that can be used to manufacture the round part of the object identified in FIGURE 4.6. (1)
- 4.7 Saving water is a high priority in South Africa. Name TWO devices that can help reduce water consumption in our homes. (2)
- 4.8 Explain, in FOUR steps, how an airlock can be removed from a pipe system. (4)
- 4.9 Usually poor installation of water pipes is the cause of noises or hammering in pipes. Give TWO examples of poor installation that may cause water hammering. (2)
- 4.10 Name ONE tool that can be used to thread and cut galvanised pipes. (1)
- 4.11 Name any TWO water systems or appliances that can be tested with a water pressure testing pump. (2)
- 4.12 Explain ONE reason for water leaking through a ceiling. (1)
- [40]**

QUESTION 5: ROOFWORK, STORM WATER AND GRAPHICS AS MEANS OF COMMUNICATION (SPECIFIC)

Start this question on a NEW page.

5.1 FIGURE 5.1 below is a sketch of a part of a gutter and downpipe installation.

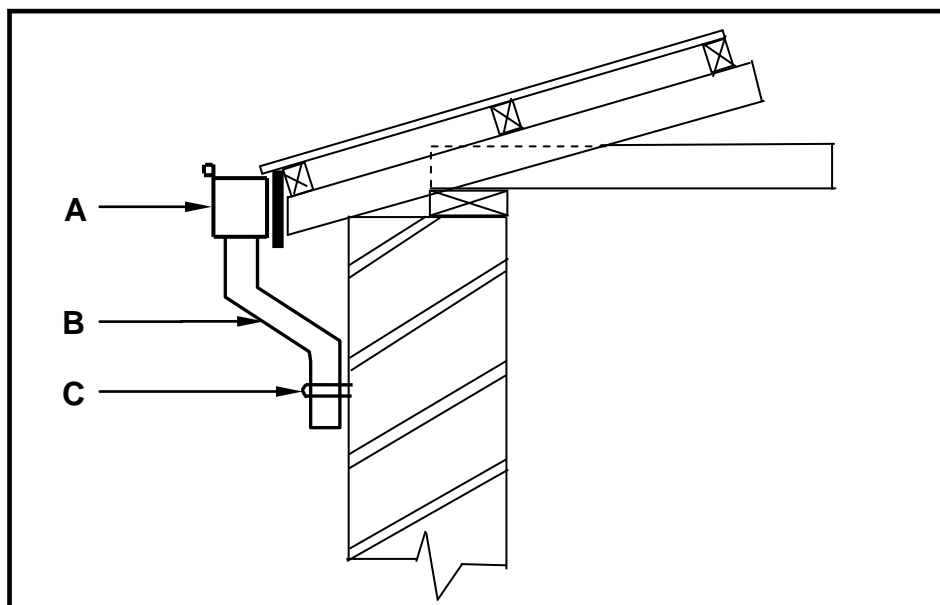

FIGURE 5.1

- 5.1.1 Identify **A**. (1)
- 5.1.2 Identify **B**. (1)
- 5.1.3 Identify **C** that is used to fasten the downpipe to the wall. (1)
- 5.1.4 A worker has to install gutters to the roof of a three-storey building. What safety equipment should the worker use to ensure his/her own safety when working in high places? (1)
- 5.2 A roof with a large surface area is supplied with a gutter with only one outlet and downpipe. What will be the consequence if it rains heavily and only one downpipe has been installed? (1)
- 5.3 Explain TWO methods to channel storm water to catchment areas. (2)
- 5.4 Name the TWO responsibilities of municipalities with regard to storm-water disposal. (2)
- 5.5 A concrete shoe can be placed underneath a downpipe to channel water away from a house. Make a neat freehand isometric sketch to indicate what this concrete shoe looks like. (4)
- 5.6 ANSWER SHEET 5.6 shows a drawing of a truncated cone. Use the drawing and information on the ANSWER SHEET and draw the development of the cone. Show ALL construction lines. Do NOT redraw the drawing, project the development from the drawing given. (17)
- HINT:** To calculate the circumference of the circle use the formula: $\pi \times d$. (17)

[30]

QUESTION 6: DRAINAGE (SEWERAGE) SYSTEMS AND SANITARY FITTINGS (SPECIFIC)

6.1 Differentiate between a *rodding eye* and a *manhole* in terms of the size and time taken to install each. Tabulate your answer. (4)

6.2 Draw a neat freehand sketch of the sectional view of a French drain to show the following in the correct position: (3)

- Gravel fill
- Coarse sand
- Compacted filling

6.3 FIGURE 6.3 below shows a water trap.



FIGURE 6.3

6.3.1 Name the trap in FIGURE 6.3. (1)

6.3.2 Explain the function of the water that remains at the base of the trap every time that water is discharged into the fitting. (1)

6.4 FIGURE 6.4 below is a drawing of a sewage system. Study the drawing and answer the questions that follow.

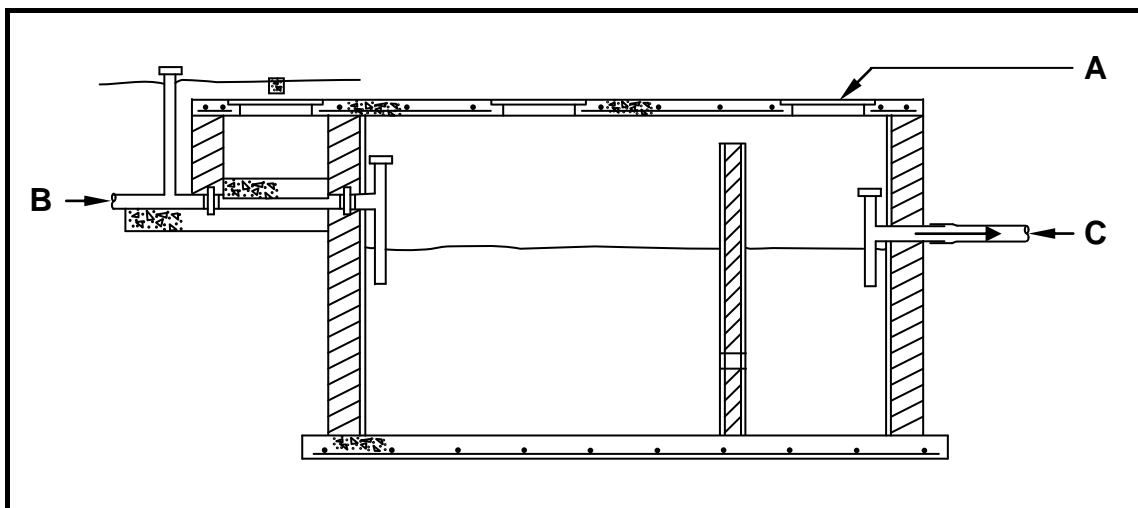

FIGURE 6.4

6.4.1 Name the sewage system in FIGURE 6.4. (1)

6.4.2 Identify part **A**. (1)

6.4.3 Explain the main function of this system. (1)

6.4.4 Predict what will happen if outlet pipe **C** is installed at a higher level than the inlet pipe **B**. (2)

- 6.5 FIGURE 6.5 below is a drawing of a typical sink installation. Study the drawing and answer the questions that follow.

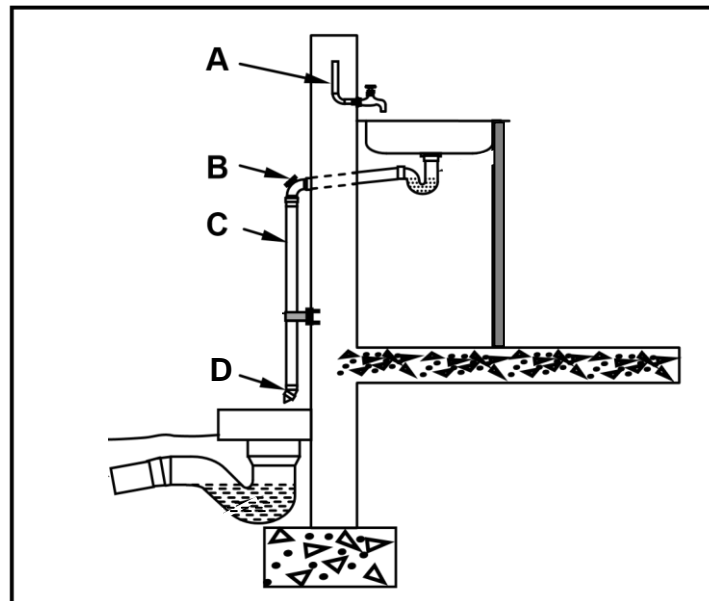

FIGURE 6.5

- 6.5.1 Recommend ONE type of pipe than can be used for **A**. (1)
- 6.5.2 Explain the function of part **B**. (1)
- 6.5.3 Name ONE material that pipe **C** can be made from. (1)
- 6.5.4 Recommend a suitable angle (degrees) for the PVC bend at **D**. (1)
- 6.5.5 What should the diameter of pipe **C** be? (1)
- 6.6 Blockages can occur in any water closet and water closet discharge pipe. This can be caused by flushing inappropriate objects down the water closet. Name TWO materials or objects than could cause blockages in this instance. (2)
- 6.7 Name any TWO acceptable tools that can be used to unblock a blocked drain. (2)
- 6.8 Colour coding is used on a site plan to make it easier to interpret. Name the colour that would be used to indicate the following on a drawing:
- 6.8.1 Soil pipes (1)
- 6.8.2 All existing drains (1)
- 6.9 Draw the SANS approved symbols for the following sanitary fittings:
- 6.9.1 Sink (2)
- 6.9.2 Bidet (2)
- 6.9.3 Bath (2)

6.10 FIGURE 6.10 on ANSWER SHEET 6.10 shows the layout of a drainage system for a small dwelling. Study the drawing and answer the questions that follow.

6.10.1 Complete the drawing on ANSWER SHEET 6.10 by printing the abbreviations for the following in the correct places on the drawing:

- 1 x rodding eye
- 1 x inspection eye
- 1 x gully
- 1 x ventilation pipe

(4)

6.10.2 Explain why it is not safe to work alone in a deep manhole.

(1)

6.10.3 Use ANSWER SHEET 6.10 and measure and calculate the total length of PVC pipe that will be needed for this drainage system, if 1 mm on the drawing is equal to 100 mm of pipe. Your answer must be in metres.

(4)
[40]

TOTAL: 200

CENTRE NUMBER:										
-----------------------	--	--	--	--	--	--	--	--	--	--

EXAMINATION NUMBER:																			
----------------------------	--	--	--	--	--	--	--	--	--	--	--	--	--	--	--	--	--	--	--

ANSWER SHEET 2.1

NO.	QUESTIONS	ANSWERS	MARKS
1	Identify FIGURE A.		1
2	Identify FIGURE B.		1
3	Identify FIGURE D.		1
4	What do the short dashed lines in FIGURE B indicate?		1
5	What type of roof is used on this building?		1
6	Name the scale that was used to draw FIGURE B.		1
7	Name the scale that was used to draw FIGURE D.		1
8	On what side of the building is the bathrooms situated?		1
9	What is indicated by number 1?		1
10	What is indicated by number 2?		1
11	What is indicated by number 3?		1
12	What is indicated by number 4?		1
13	What is indicated by number 5?		1
14	What is indicated by number 6?		1
15	What is indicated by number 7?		1
		TOTAL	15

CENTRE NUMBER:																				
EXAMINATION NUMBER:																				

ANSWER SHEET 2.2

ASSESSMENT CRITERIA	MARKS	LM
External walls	3	
NGL (correctly indicated)	1	
FFL (correctly indicated)	1	
Window	1	
Window sill	1	
Door opening	1	
Step gable	1	
Fascia board	1	
Barge board	2	
Roof (correctly drawn)	3	
Gutter	1	
Rainwater downpipe	1	
Ridge capping	1	
Determining roof height	2	
Any two labels	2	
Application of scale One or two incorrect = 3 Three or four incorrect = 2 More than five incorrect = 1 No measurement correct = 0	3	
TOTAL	25	

A 

CENTRE NUMBER:

--	--	--	--	--	--	--	--	--	--

EXAMINATION NUMBER:

--	--	--	--	--	--	--	--	--	--	--	--	--	--	--	--	--	--

ANSWER SHEET 3.1

3.1.3

3.1.4



(2)

A																	A

(2)

3.1.3

ASSESSMENT CRITERIA	MARK	LEARNER MARK
Stretcher course	1	
Header course	1	
TOTAL	2	

3.1.4

ASSESSMENT CRITERIA	MARK	LEARNER MARK
Top view of stretcher course showing two rows of bricks correctly drawn	2	
TOTAL	2	

CENTRE NUMBER:									
-----------------------	--	--	--	--	--	--	--	--	--

EXAMINATION NUMBER:														
----------------------------	--	--	--	--	--	--	--	--	--	--	--	--	--	--

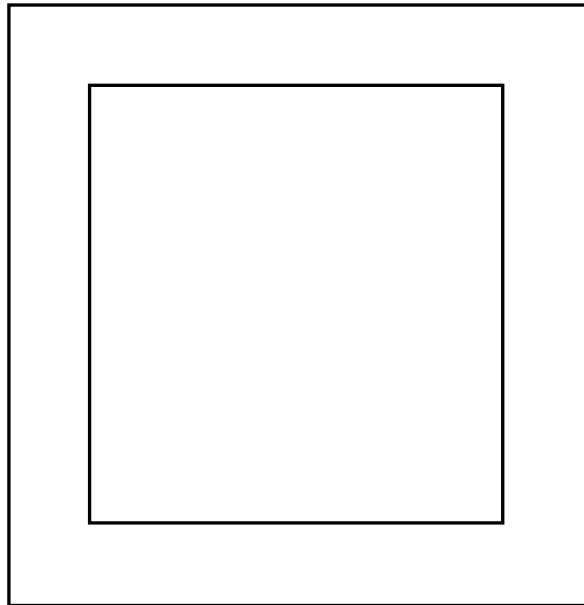
ANSWER SHEET 3.2

ASSESSMENT CRITERIA	MARK	LEARNER MARK
Hidden detail where pipes passes under wall	2	
Open channel. Show double line for cut pipe	1	
Junction correctly drawn	2	
Branch pipe correctly drawn	2	
TOTAL:	7	

CENTRE NUMBER:

EXAMINATION NUMBER:

ANSWER SHEET 5.6

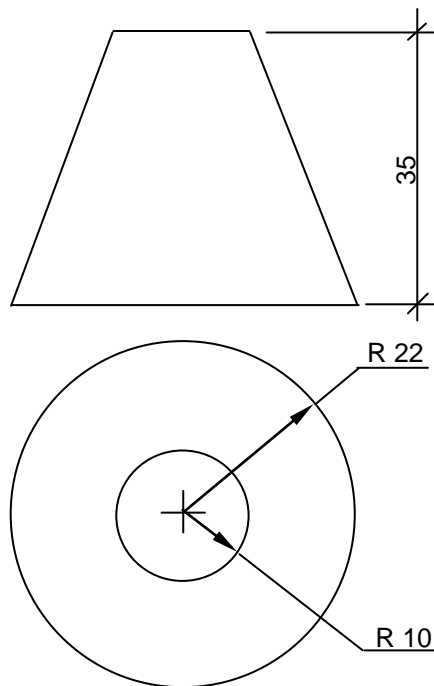

ASSESSMENT CRITERIA	MARK	LM
Construction lines to top of cone	2	
Construction line of outer circle	1	
Construction line of inner circle	1	
Calculation of circumference of circle and 12 equal parts	4	
Divide outer circle into 12 parts	2	
Construction lines from top of cone to outer circle	3	
Outside lines of development	2	
3 mm seam on both sides	2	
TOTAL:	17	

CENTRE NUMBER:

EXAMINATION NUMBER:

ANSWER SHEET 6.10

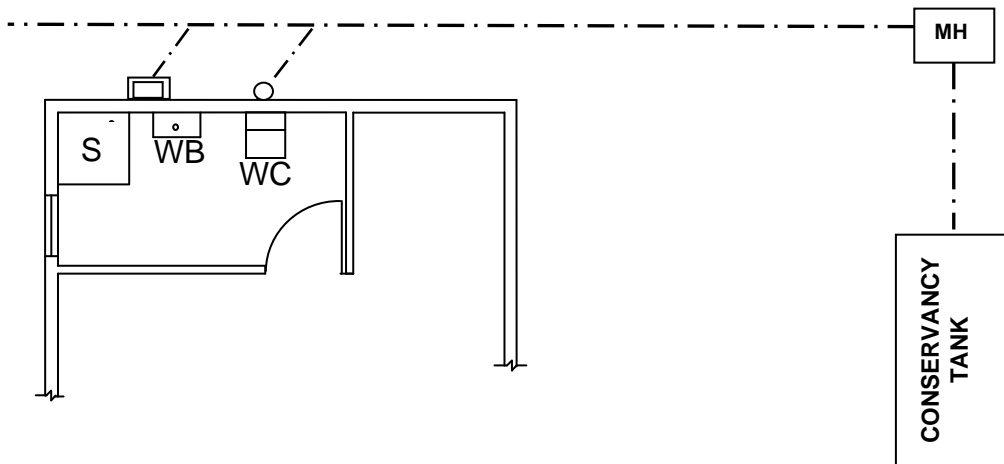

ASSESSMENT CRITERIA	MARK	CANDIDATE'S MARK
Rodding eye	1	
Gully	1	
Ventilation pipe	1	
Inspection eye	1	
TOTAL	4	