



basic education

Department:
Basic Education
REPUBLIC OF SOUTH AFRICA

CONSUMER STUDIES (PRODUCTION OF SOFT FURNISHING ARTICLES)

GUIDELINES FOR PRACTICAL ASSESSMENT TASKS

GRADE 12

2018

These guidelines consist of 22 pages.

THE PRACTICAL ASSESSMENT TASK FOR CONSUMER STUDIES PRODUCTION OF SOFT FURNISHING ARTICLES

1. INTRODUCTION

The 16 Curriculum and Assessment Policy Statement subjects which contain a practical component all include a practical assessment task (PAT). These subjects are:

- **AGRICULTURE:** Agricultural Management Practices, Agricultural Technology
- **ARTS:** Dance Studies, Design, Dramatic Arts, Music, Visual Arts
- **SCIENCES:** Computer Applications Technology, Information Technology
- **SERVICES:** Consumer Studies, Hospitality Studies, Tourism
- **TECHNOLOGY:** Civil Technology, Electrical Technology, Mechanical Technology and Engineering Graphics and Design

A practical assessment task (PAT) mark is a compulsory component of the final promotion mark for all candidates offering subjects that have a practical component and counts 25% (100 marks) of the end-of-year examination mark. The PAT is implemented across the first three terms of the school year. This is broken down into different phases or a series of smaller activities that make up the PAT. The PAT allows for learners to be assessed on a regular basis during the school year and it also allows for the assessment of skills that cannot be assessed in a written format, e.g. test or examination. It is therefore important that schools ensure that all learners complete the practical assessment tasks within the stipulated period to ensure that learners are resulted at the end of the school year. The planning and execution of the PAT differs from subject to subject.

- During the practical assessment task for the Production of Soft Furnishing Articles the learner must demonstrate his/her knowledge and practical ability/skills to produce soft furnishing articles focusing on suitability for selling.
- The practical assessment task for Consumer Studies, Production of Soft Furnishing Articles for Grade 12 consists of a layout and cutting session (part of practical examination 1) and two practical examinations of three hours each. Learners perform these practical examinations individually.
 - **Term 2: Practical examination 1 (plus layout and cutting session)**
Learners will make half of the article selected for the micro-enterprise used for the project in term 1.
 - **Term 3: Practical examination 2**
Learners will complete the article started in practical examination 1.

2. MARK ALLOCATION

- Each examination consists of 100 marks. The mark for the final practical assessment task is obtained by combining the marks for the two practical examinations as indicated below:

Practical examination 1: term 2 (includes layout and cutting)	100
Practical examination 2: term 3	100
Total	200 ÷ 2
Final mark for PAT	100

- The marks for the PAT are part of the end-of-the-year assessment.
- The province will provide two separate computerised mark sheets, one for SBA and one for the PAT. Both mark sheets must be signed by the teacher, principal and moderator.

3. REQUIREMENTS FOR THE PRACTICAL ASSESSMENT TASK

Consumer Studies is a choice subject with five practical options. If the school chooses to offer Consumer Studies as a subject and selects the Soft Furnishings practical option, the equipment and funds necessary to conduct the PAT are the responsibility of the school as specified in the CAPS document. (See p 11)

Ensure the following:

- A suitable classroom with the necessary equipment must be available: large tables for cutting out; two or more ironing boards and irons; cutting-out scissors (one for each learner); equipment for measuring and marking.
- A minimum of R80 to a maximum of R100 per learner for EACH of the two practical examinations is required to make the required articles, besides the funding required for the SBA practical lessons.
- Divide the learners into groups with a maximum of 12 learners. Twenty-four learners (two groups of 12 learners) can perform the examination on the same day, e.g. from 08:00 to 11:00 and from 12:00 to 15:00.
- The teacher will need time between the two sessions to prepare the classroom for the following group.
- Schools with large numbers of learners will need more than one day to complete the examination.

4. REQUIRED TIME FRAME

- Layout and cutting is done beforehand in a ONE-HOUR session under examination conditions.
- A time frame of 3 HOURS in total is required per examination (excluding the one-hour layout and cutting session before practical examination 1).

5. SETTING THE EXAMINATIONS

5.1 Practical examination 1 (term 2)

- This practical examination **must be slotted into the test and examination timetable in the second term.**
- Learners will make the article that has been selected for their micro-enterprise (project term 1). The production process, workmanship and saleability of the articles form an important aspect of the examination.
- Teachers must buy a commercial pattern for an article that can be completed in 6 hours with the skills learners gained during the practical lessons for SBA in Grades 10 and 11.
- Teachers have two options when selecting the pattern for the practical examinations:
 - Buy a commercial pattern for an article that can be completed in 7 hours (one-hour layout and cutting out, practical examination 1 and practical examination 2);
 - OR**
 - Use the same commercial pattern used in the practical lessons and remake the same article once more in 7 hours (one-hour layout and cutting out, practical examination 1 and practical examination 2).
- The article selected should have a minimum skills-code weighting of 100 points.
- The techniques to be completed per practical examination should have a total skills-code weighting of 50 points.

NSC (Production of Soft Furnishing Articles)

- Learners must complete the one-hour layout and cutting session under examination conditions prior to the day of practical examination 1.
- Learners should start and complete half the article in practical examination 1.
- After three hours learners should hand in their articles for marking. After the marking has been completed the articles have to be returned to learners for correction and finishing off, if necessary. The articles will NOT be remarked after the corrections have been made.

5.2 Practical examination 2 (term 3)

- This practical examination will take place on a date agreed upon with the moderator.
- The learners will be assessed on the production process, workmanship and the saleability of the articles.
- A time frame of 3 hours in total is required for this practical examination.
- The techniques to be completed should have a skills-code weighting of 50 points.
- After three hours learners should hand in their articles for final marking. After the marking has been completed the articles have to be returned to learners for correction and finishing off, if necessary. The articles will NOT be remarked after the corrections have been made.

6. PREPARING FOR THE PRACTICAL EXAMINATION**The teacher is responsible for the following:**

- Set the dates for both examinations. Communicate these dates to the SMT of the school to ensure that these dates do not clash with other school activities.
- Copy the pattern, illustration(s) and instruction sheet for each learner or buy a pattern for each learner. It is compulsory for each learner to work from an instruction sheet.
- Prepare the mark sheets provided with learners' names and their examination numbers.
- Learners must receive the pattern and instructions **one week (7 school days)** prior to the layout and cutting session.
- Purchase the fabric and haberdashery, cut the fabric to the required size for each learner.
- Make up a 'kit' for each learner and include the following:
 - Fabric in the required size
 - The pattern and instruction sheet
 - The necessary haberdashery, such as a zip, buttons, pins, etc.
- Check and service all sewing machines that are available to ensure they are all in good working order.
- Divide learners into groups according to the number of learners that can easily be accommodated in the room.
- Thread all the sewing machines with the appropriate colour thread and test the tension beforehand.
- Prepare the classroom and ensure the availability of the following:
 - Electrical power points and extension cords for all irons and sewing machines
 - Irons and ironing boards
 - Large tables for the layout and cutting out of articles
 - Enough small equipment such as scissors, needles, quick-unpicks, pins, thread, bobbins, extra sewing machine needles and sharp scissors

7. PERFORMING THE PRACTICAL EXAMINATIONS

7.1 Practical examination 1 in term 2: 4 hours

7.1.1 The layout and cutting out session: 1 hour (prior to practical examination 1)

- Hand out each learner's 'kit' with the fabric, pattern instruction sheet and haberdashery, such as the zip.
- The teacher is NOT allowed to assist the learners in any way during the cutting session.
- During the cutting session the teacher allocates marks.
- Learners may improve/correct the cut-out pattern pieces or cut out new pieces after the cutting session is over and marks have been allocated, but this will NOT be remarked.
- The teacher then keeps all the learners' pattern pieces in a safe place until the day of practical examination 1.

7.1.2 Practical examination 1 in term 2: 3 hours

- When learners enter the classroom hand them their 'kits' with the cut-out articles and extra scraps of material
- Enough scissors, pins and needles should be available.
- The sewing machines must be ready at the tables.
- Individual learners, under the supervision of the teacher, should perform this practical examination.
- The articles should be ready for marking after 3 hours.
- Learners will lose **2 marks for every 5 minutes late** up to a maximum of 20 marks.
- Only the teacher, the moderator and the candidates may be present in the room during the practical examination.
- The teacher must invigilate and assess the learners while they are performing the practical examination and he/she may NOT do any other work or assist the learners in any way.
- The teacher must mark practical examination 1 and record the marks. After marking the learners may do corrections or complete the articles up to the required stage where practical examination 2 starts. The articles will NOT be remarked after the corrections have been made.
- After corrections have been made the articles are returned to the 'kit' to be stored in a safe place until the day of practical examination 2.

7.2 Practical examination 2 in term 3: 3 hours

- When learners enter the classroom, hand them their 'kits' with the half completed articles and extra scraps of fabric.
- Enough scissors, pins and needles should be available.
- The sewing machines must be ready at the tables.
- Individual learners, under the supervision of the teacher, perform practical examination 2.
- The articles should be ready for assessment after 3 hours. Learners will lose **2 marks for every 5 minutes late** up to a maximum of 20 marks.
- Only the teacher, the moderator and the candidates may be present in the room during the practical examination.

- The teacher must invigilate and assess the learners while they are performing the practical examination and he/she may NOT do any other work or assist the learners in any way.
- The teacher must mark practical examination 2 and record the marks. After marking the learners may make corrections or complete the articles. The articles will NOT be remarked after the corrections have been made.
- After the corrections have been made the articles are handed in and kept in a safe place until the day of moderation

8. EVALUATION

- The teacher and external moderator have one hour to evaluate the final products, inspect the learners' workstations and complete the mark sheets.
- The learners should tidy their workstations on completion of the examination so that the teacher/moderator may inspect the workstations for the final allocation of marks.

9. MODERATION OF THE PRACTICAL ASSESSMENT TASK

9.1 BEFORE practical examination 1

The subject advisor must receive and moderate the following before the end of term 1 to ensure that the practical examination is of an appropriate standard:

- The selected article indicating the weighting of techniques according to the skills code
- A photocopy of the pattern envelope
- An illustration of the article
- The list of fabrics, haberdashery, etc. to be purchased
- The estimated cost per learner
- The completed checklist, checked and signed by the principal
- An instruction page for the learners with the assessment criteria and mark allocation for the practical examination sessions
- Planning for all three sessions (layout and cutting, practical examination 1 and practical examination 2) indicating the total weighting of techniques

The PAT cannot be done unless it was approved by the subject advisor.

9.2 ON THE DAY of practical examination 2

- During term 3 the last group of a maximum of 12 learners will be externally moderated by the subject advisor while they perform the practical examination at the school.
- The teacher must have the following available for the moderator on the day of moderation:
 - All the articles that learners made during the weekly practical classes for SBA (if not moderated during SBA moderation)
 - A copy of the completed mark sheet for practical lessons
 - The completed articles (marked) of all the learners who have already completed practical examination 2
 - The marks of all learners who have already completed practical examination 2
 - A separate set of assessment tools for the moderator to use, with the names and examination numbers of the learners already on the mark sheet

NSC (Production of Soft Furnishing Articles)

- The moderator will randomly select SIX learners and independently assess them while they are performing the examination as well as the articles produced by the selected learners.
- Afterwards the moderator will compare his/her assessment with the assessment of the teacher. If the moderator finds that the marks of the teacher differ more than 10% from his/her marks, a block adjustment upwards or downwards should be made based on the difference.
- The computerised mark sheet must be completed on the day of moderation.
- The table below demonstrates how to determine the difference between the moderator's marks and teacher's marks to establish whether adjustment is needed and the margin of adjustment required:

Learner's Name				PAT 2	
				100	
				*T	*M
Learner A				84	69
Learner B				83	70
Learner C				68	53
Learner D				59	44
Learner E				49	40
Learner F				45	40
TOTAL				388	316
AVERAGE MARK = TOTAL ÷ 6 (number of learners)				66	53
DIFFERENCE = 66 (*T) – 53 (*M)				13	
ADJUSTMENT	DOWNWARDS	✓	UPWARDS	- 3	

*T = Teacher; *M = Moderator

- A block adjustment can also be made based on the professional judgement of the moderator, if the practical exam of the school is not of the expected standard.
- The moderator will discuss the outcome and any adjustments with the teacher. The final moderated marks should then be entered on the computerised mark sheet.
- The marks of all learners will be affected if an adjustment is made.
- The marks of all the learners need to be finalised and mark sheets must be signed by the subject advisor and principal on the day of this examination. The computerised mark sheet must be completed on the day of moderation.

SKILLS-CODE WEIGHTING OF TECHNIQUES USED FOR THE PRODUCTION OF SOFT FURNISHING ARTICLES

- Use the following skills-code weighting to choose a pattern for the PAT as well as for the weekly practical lessons.
- The skills code indicates the weighting for the techniques and NOT the mark allocation.
- A weighting is allocated to a technique according to the degree of difficulty of the technique.
- The total weighting of the techniques in EACH practical examination in Grade 12 should add up to minimum of 50 skills-code points.
- **Points for the same technique cannot be awarded twice** in the same practical examination.
- The teacher could add a technique not listed below, after discussing it with the subject advisor. The teacher and subject advisor should then decide on the weighting of the new technique.

Layout and cut from commercial pattern	12	Zip	15
<ul style="list-style-type: none"> • Fabric folded correctly • Pattern placed on straight grain of fabric • All relevant pieces placed on fold • Pattern pieces pinned correctly onto fabric • Straight cutting on cutting lines • Notches accurately cut • Pattern markings 	1 1 2 2 2 2 2	<ul style="list-style-type: none"> • Seam allowance correct and even width • Seam finishing • Insert zip: stitching straight, correct width from zip • Corners at bottom of zip neat and square • Corners at top of zip neat and square 	2 3 5 3 2
Layout and cutting from measurements, no pattern	15	Fitted corners	10
<ul style="list-style-type: none"> • Fabric folded correctly • Measurements marked on fabric accurately • Straight grain of fabric used correctly • Straight cutting 	2 3 5 5	<ul style="list-style-type: none"> • Measure and cut • Stitch seam to make corners • Finish seam • Attach elastic 	3 2 2 3
Patchwork design	10	Quilting	20
<ul style="list-style-type: none"> • Patchwork pattern designed on paper • Design matches the choice of fabric and article • Level of difficulty (<i>number and shape of patches; refer to CAPS for techniques per grade</i>) 	2 3 5	<ul style="list-style-type: none"> • Sandwiching top layer, batting and lining • Tacking the three layers • Mark stitching lines • Accurate stitching 	5 6 4 5
Layout and cutting of pattern pieces (Patchwork pieces, lining and batting included)	20	Using Velcro/fasteners	5
Patchwork:		<ul style="list-style-type: none"> • Stitched correctly and neatly • Correct position 	3 2
<ul style="list-style-type: none"> • Measure and cutting fabric patches accurately • Size of fabric pieces suitable for size of article • Correct number of patchwork pieces 	5 3 2	Decorating other than embroidery	5
Other pattern pieces:		<ul style="list-style-type: none"> • Suitable for article • Neat stitches 	2 3
<ul style="list-style-type: none"> • Pattern pieces placed economically on fabric • Lining and batting pattern pieces measured and accurately marked on fabric • Straight cutting 	2 5 3	Crossway binding	20
Seams/Joining of patchwork pieces	15	<ul style="list-style-type: none"> • Cutting bias strips • Join bias strips • Attach binding for edge finishing <ul style="list-style-type: none"> ○ Correct and even width ○ Lies flat and even ○ Machine or hand stitched 	5 5 5 2 3 3
<ul style="list-style-type: none"> • Patches joined according to design • Even small stitches • Straight seams/smooth curves/square corners • Seam allowance = 0,5 cm • Alignment of patches • Final appearance 	2 2 2 3 2 2	Crossway piping	20
Seams and seam finishing(assemble article: e.g. bag)	10	<ul style="list-style-type: none"> • Cutting bias strips • Join bias strips • Make piping • Shrinking string • Insert piping into seam 	5 5 5 2 3
Open or closed straight seams with a finish		Narrow single hems	8
<ul style="list-style-type: none"> • Straight stitching • Correct seam allowance and even width • Seam finishing 	3 4 3	<ul style="list-style-type: none"> • Even and correct width • Neatly over-locked • Folded over evenly • Neatly stitched 	2 2 2 2

NSC (Production of Soft Furnishing Articles)

Stitched-on pocket	10	Embroidery decoration: three to five decorative stitches by hand	10
<ul style="list-style-type: none"> • Pocket shape, size hem/seams • Correct position on article • Stitching to attach pocket to article 	3 2 5	<ul style="list-style-type: none"> • Good design, suitable for article • Good choice of colours • Embroidery stitches – workmanship 	3 3 4
Pillowcase	10	Curtain lining	10
<ul style="list-style-type: none"> • Fold over facing correct way/hem even neat • Seams even/neat (French/open) • Straight sewing • Corners trimmed 	3 3 2 2	<ul style="list-style-type: none"> • Straight seams • Hem • Blanket stitch loops (positioning of lining) • Shorter and narrower (even finish) 	2 3 3 2
Buttons on cushions/decorative	5	Attach curtain tape	5
<ul style="list-style-type: none"> • Loose stitching through all layers • Finishing off with blanket stitching • Buttons covered with suitable material 	2 2 1	<ul style="list-style-type: none"> • Straight stitching 3 rows • Correct position on curtain 	3 2
Attaching borders	10	Fasteners: loop and hook/button/press stud/button and buttonhole	5
<ul style="list-style-type: none"> • Even width • Straight stitching/no creases (seam to attach) • Neat symmetric corners • No loose threads/untidy joints 	2 3 3 2	<ul style="list-style-type: none"> • Correct spacing/size • Correct stitch • Buttons firmly stitched 	2 1 2
Mitred corners	12	Covered pelmets	10
<ul style="list-style-type: none"> • Exact width measurement right around • 45° corners cut with seam allowance • Sew corners and cut off excess • Fold allowance in and tack sides evenly through three layers • Top stitch evenly through all layers. No creases or folds. 	2 2 2 3 3	<ul style="list-style-type: none"> • Cut to shape/design • No frays/threads • Finish/even stitching/corners trimmed/evenly turned out/corners trimmed correctly 	3 3 4
Frills	20	Choice of fabric <i>(Teacher should have a box from which learners can choose.)</i>	10
<ul style="list-style-type: none"> • Hems: narrow, even with neat stitching • Correct stitch length for gathers • 2/3 rows gathering stitches • Pull-up gathers distributed evenly • Attach frill to article • Straight stitching in middle of gathering stitches • Seam finishing 	3 1 2 3 4 4 3	<ul style="list-style-type: none"> • Fabric types match for easy wash and care • Colours match and have a striking effect • Motifs/Design/Pattern of fabric small and suitable for patchwork 	3 3 4
Embellishments	5	Cutting/Shapes of fabric patches	5
<ul style="list-style-type: none"> • Enhance design • Neatly and firmly sewn on 	2 3	<ul style="list-style-type: none"> • Crazy patchwork size of fabric pieces suitable for size of article • Fabric pieces accurately cut 	2 3
Seams and seam finishing	10	Edge finish	15
Curved seam		<ul style="list-style-type: none"> • Cut and join crossway strips for crossway binding • Cut straight binding accurately to measurements/pattern • Attach binding for edge finishing <ul style="list-style-type: none"> ○ Correct and even width ○ Lies flat ○ Neatly stitched 	5 4 2 2 2
<ul style="list-style-type: none"> • Straight stitching • Correct seam allowance and even width • Seam finishing • Smooth curve 	2 3 3 2	Bands/Straps (handles for bags/purse)	10
Seams and seam finishing	12	<ul style="list-style-type: none"> • Even width, suitable for bag • Reinforced inside with suitable fabric • Attached to bag and reinforced on bag 	3 2 5
Seams with corners:		Quality and saleability	10
<ul style="list-style-type: none"> • Straight stitching • Correct seam allowance and even width • Seam finishing • Corners 	3 3 3 3	<ul style="list-style-type: none"> • General finishing • Overall neatness • Fit for purpose 	3 3 4
Bands/straps (handles for bags/purse)	10	Lining for bag	10
<ul style="list-style-type: none"> • Even width, suitable for bag • Reinforced inside with suitable fabric • Attached to bag and reinforced on bag 	3 2 5	<ul style="list-style-type: none"> • Seams • Correct size/no pleats/folds • Neatly attached 	4 3 3
Quality & Saleability	10		
<ul style="list-style-type: none"> • General finishing • Overall neatness • Fit for purpose 	3 3 4		

**TEACHER PLANNING:
GRADE 12 PRACTICAL EXAMINATIONS 1 AND 2)**
(To be submitted to the subject advisor for moderation at the end of term 1)

Name of school:
Name of teacher:
Date and time of examination sessions:

PRACTICAL EXAMINATIONS FOR PAT GRADE 12
(Attach copies of patterns and instruction sheets)

LAYOUT AND CUTTING	
TECHNIQUES	WEIGHTING
TOTAL	

PRACTICAL EXAMINATION 1 (TERM 2)	
TECHNIQUES	WEIGHTING
TOTAL	

PRACTICAL EXAMINATION 2 (TERM 3)	
TECHNIQUES	WEIGHTING
TOTAL	

EXAMPLE OF TEACHER PLANNING FOR PURCHASES*(To be submitted to the subject advisor for moderation at the end of term 1 or earlier)*

Total number of learners	Groups	Number of learners per group	Dates	Time
25	1	8	10/09/2018	08:00–11:00
	2	8	10/09/2018	12:30–15:30
	3	9	11/09/2018	08:00–11:00

Practical Examination	Requirements per learner	Quantity required per learner	Number of learners	Total
1/2	100% cotton (30 cm x 3)	90 cm	25	22,5 metres
	Sewing thread	1 reel		25 reels
	Pattern	1		25 patterns
	Batting	1 m		25 metres
	Thread for basting	1		25 reels
	Lace/braid	1		12,5 metres

TEACHER'S SHOPPING LIST

Requirements	Amount	Approximate cost
100% cotton	22,5 metres	
Sewing thread	25 reels	
Pattern	25 patterns	
Batting	25 metres	
Thread for basting	25 reels	
Lace/braid	12,5 metres	

Approximate cost of shopping list:

ESTIMATED COST PER LEARNER:

TEACHER PLANNING FOR PURCHASES

(To be submitted to the Subject Advisor for moderation at the end of term 1 or earlier)

Total number of learners	GROUPS	Number of learners per group	Dates	Time

PAT	Requirements per learner:	Quantity required per learner	Number of learners	Total

TEACHER'S SHOPPING LIST

Requirements	Amount	Estimated Cost

Estimated cost of shopping list:

ESTIMATED COST PER LEARNER:

**CONSUMER STUDIES PRACTICAL OPTION: PRODUCTION OF SOFT FURNISHING ARTICLES
CHECKLIST FOR PLANNING TO BE HANDED IN FOR MODERATION**

SCHOOL		
TEACHER		
PRINCIPAL		
DATE SUBMITTED		
Dates of all practical examination sessions	Proposed moderation date	Approved moderation date

CRITERIA	YES/NO	COMMENTS BY MODERATOR
Items included		
An illustration of the article/ photo copy of the pattern envelope		
Copy of the pattern, instruction sheet to be provided to learners		
Completed techniques and weighting of article for Practical Examinations 1 and 2		
Assessment criteria for techniques		
List of purchases		
Estimated cost per learner		

APPROVED/NOT APPROVED

RESUBMISSION DATE: _____

Signatures:

TEACHER: _____ DATE: _____

PRINCIPAL: _____ DATE: _____

MODERATOR: _____ DATE: _____

CRITERIA FOR TECHNIQUES USED:

Neatness of article	<ul style="list-style-type: none"> • No dirty marks/fabric clean, • No loose threads • No scorch marks • No visible pattern markings 	(10)
Prescribed techniques completed	<ul style="list-style-type: none"> • All techniques successfully completed 	(10)
Stitching	<ul style="list-style-type: none"> • Stitch length suitable for fabric • Colour of quilting thread must be suitable for the required effect • Stitch tension correct • Stitching must be securely ended off • Units accurately sewn with seams that are exactly the same width • Hand-quilting stitches should be small and even on both top and backing 	(10)
Construction	<ul style="list-style-type: none"> • Batting should be firmly secured to prevent it from shifting • Bag should be neatly assembled • Handles securely attached • Pockets neatly attached to bag lining • Lining should fit neatly 	(20)
Finishing	<ul style="list-style-type: none"> • No loose threads • Dividers and borders must be neatly finished off • No scorch marks/neatly ironed/ironed 	(10)

- 0-1 Unacceptable, does not meet the requirements, cannot sell
2-3 Poor, meets some requirements, will not sell
4-6 Average, meets most requirements, should sell
7-8 Good, meets all the requirements, should sell well
9-10 Excellent, exceeds all requirements, will sell very well

MARK SHEET FOR PRACTICAL OPTION: PRODUCTION OF SOFT FURNISHING ARTICLES												
Practical Examination 1 (Term 2)												
SCHOOL		NAMES OF LEARNERS										
		1	2	3	4	5	6	7	8	9	10	11
DATE												
EXAMINER												
1	PRACTICAL SKILLS AND TECHNIQUES											
	Layout and cutting of pattern pieces (patchwork, lining and batting included)											
	Patchwork:	15										
	Measure and cut fabric patches accurately	2										
	Size of fabric pieces suitable for size of fabric	3										
	Correct number of patchwork pieces	3										
	Other pattern pieces:											
	Pattern pieces placed economically on fabric	2										
	Lining and batting pattern pieces measured and accurately marked on fabric	2										
	Straight cutting	3										
2	PRACTICAL SKILLS AND TECHNIQUES	5										
	Pattern interpretation											
	Follow pattern instructions	3										
	Efficient use of time	2										
	Use of equipment	5										
	Correct handling of small equipment, e.g. tape measure, scissors, needles, etc.	2										
	Correct handling of large equipment, e.g. sewing machine, overlocker, iron, etc. (Machines correctly threaded and used, safe and correct use of equipment.)	3										
	NEATNESS AND ECONOMIC USE OF RESOURCES											
	Organisation of workstation and equipment	5										
	Workstation well organised	2										
Small equipment not lying around	1											
Handling of equipment after use, correct handling of off-cuts and waste (Teacher observes each learner regularly during the exam, to determine the final mark.)	2											
Personal appearance	5											
Appropriately dressed (school uniform, clean hands)												
Neatness of workstation on completion	5											
Electrical equipment unplugged, cleaned and stored securely	2											
Electrical power points switched off	2											
Work area neat and clean	1											
3	SUITABILITY FOR SELLING											
	General appearance	20										
	Neatness of article and finishing	10										
	Prescribed techniques completed	10										
	Workmanship	40										
	Stitching	10										
Construction	20											
Finishing	10											
TOTAL	100											

MARK SHEET FOR PRACTICAL OPTION: PRODUCTION OF SOFT FURNISHING ARTICLES													
Practical Examination 2 (Term 3)													
SCHOOL		NAMES OF LEARNERS											
		1	2	3	4	5	6	7	8	9	10	11	12
DATE													
EXAMINER													
1	PRACTICAL SKILLS AND TECHNIQUES												
	Pattern interpretation	15											
	Follow pattern instructions, layout, cutting	7											
	Accurate sewing techniques	8											
	Use of equipment	5											
	Correct handling of small equipment, e.g. tape measure, scissors, needles, etc.	2											
	Correct handling of large equipment, e.g. sewing machine, overlocker, iron, etc. (<i>Machines correctly threaded and used, safe and correct use of equipment.</i>)	3											
	Efficient use of time	5											
	Efficient use of time while waiting to use equipment												
2	NEATNESS AND ECONOMIC USE OF RESOURCES												
	Organisation of workstation and equipment	5											
	Workstation well organised	2											
	Small equipment not lying around	1											
	Handling of equipment after use, correct handling of off-cuts and waste (<i>Teacher observes each learner regularly during the exam, to determine the final mark.</i>)	2											
	Personal appearance	5											
	Appropriately dressed (school uniform, clean hands)												
	Neatness of workstation on completion	5											
Electrical equipment unplugged, cleaned and stored securely	2												
Electrical power points switched off	2												
Work area neat and clean.	1												
3	SUITABILITY FOR SELLING												
	General appearance	20											
	Neatness of article	10											
	Prescribed techniques completed	10											
	Workmanship	40											
	Stitching	10											
Construction	20												
Finishing	10												
TOTAL	100												

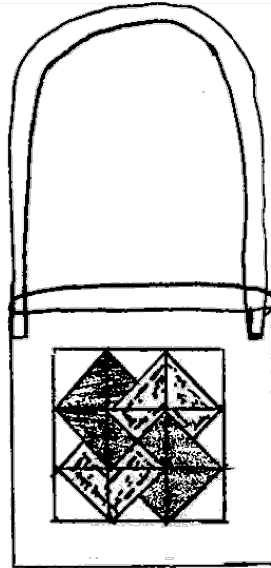
EXAMPLE OF ARTICLE FOR THE PRACTICAL ASSESSMENT TASK**ARTICLE: BAG WITH PATCHWORK****WEIGHTING:**

LAYOUT AND CUTTING PRACTICAL ASSESSMENT TASK 1	
TECHNIQUES	WEIGHTING
Design, layout and cutting of pattern pieces	20
SUBTOTAL:	20

PRACTICAL ASSESSMENT TASK 1/2	
TECHNIQUES	WEIGHTING
Choice of fabric	10
Embroidery	10
Seams	20
Embellishments	5
Quilting	20
Edge finishing/binding	15
SUBTOTAL:	80
TOTAL: 100	

FOR THE TEACHER:**REQUIREMENTS:**

Light fabric, 50 cm x 10 cm
 Printed fabric, 50 cm x 10 cm
 Dark fabric, 45 cm x 115 cm
 Batting, 30 cm x 30 cm
 Fabric for lining, 30 cm x 30 cm
 Calico, 25 x 25 cm
 Needles
 Pins
 Thread
 Scissors (cutting out and utility)
 Quilting thread
 Template A and Template B
 Embellishments

FOR THE LEARNERS:**THE LAYOUT AND CUTTING-OUT SESSION: 1 hour (examination conditions)**

- Receive the 'kit', including the fabric, pattern, instruction sheet and haberdashery, such as the lace, buttons, etc.
- During this one-hour session you will be required to cut out the pattern pieces, batting and lining.
- Transfer the pattern markings, where applicable.
- Submit the cut-out pattern pieces to the teacher for marking.
- You may improve/correct the cut-out pieces, if necessary, **after** the teacher has marked your work, but NO remarking will be done.
- Submit the pattern pieces to the teacher for safe-keeping until the day of practical examination 1.

LAYOUT AND CUTTING SESSION: 1 hour (exam conditions)

1. Cut the following pattern pieces:

- 2 x template A – light fabric
- 2 x template A – printed fabric
- 2 x template A – dark fabric
- 2 x template B – light fabric
- 2 x template B – printed fabric
- 2 x template B – dark fabric
- 4 x 25 cm x 4 cm strips
- 2 x 70 cm x 8 cm strips (straps/handles)
- 1 x 25 x 25 cm dark fabric for bag back
- 2 x 25 x 25 squares – lining fabric

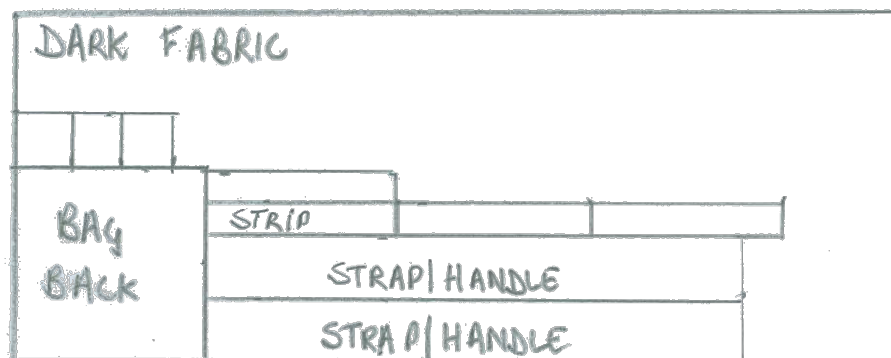
LAYOUT:

2. Transfer the pattern markings, where applicable.
3. Fold all pattern pieces and extra material and submit to teacher for marking.

PRACTICAL EXAMINATION 1: 3 HOURS

PATTERN INSTRUCTION SHEET:

Abbreviations: S = square, e.g. S1 = square 1

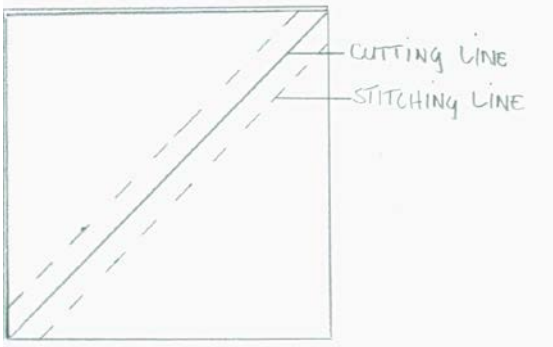
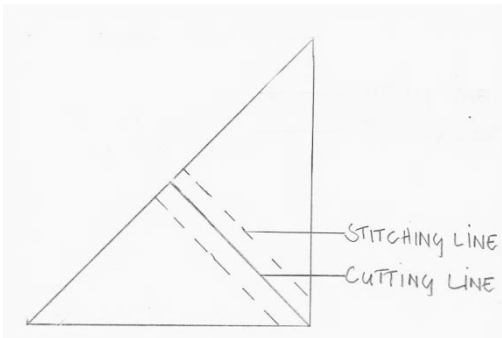
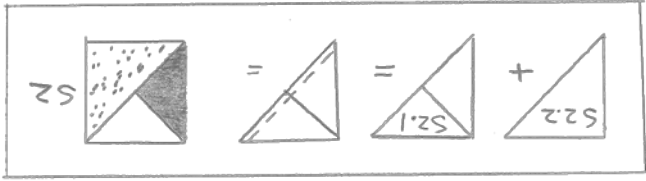
PRACTICAL EXAMINATION 1	
INSTRUCTIONS	ILLUSTRATIONS
<p>1. Place one light square on one dark square, right sides facing and stitch on stitching line, cut on cutting line. Press seam. (S1 and S9)</p>	<p>1.</p> 
<p>2. Repeat the above process with one print and one light square. (S3 and S7)</p>	
<p>3. Place one dark triangle on one print triangle, right sides facing, stitch and cut as shown in diagram. Press (S5.1 and S5.2).</p>	<p>3.</p> 
<p>4. Repeat the process above with one light and one print triangle (S4.1 and S6.1) and one dark and one light triangle (S2.1 and S8.1).</p>	
<p>5. Place S2.1 on S2.2 and stitch as shown to form square S2. Press seams.</p>	<p>5.</p> 
<p>6. Repeat the process above with S4.1 and S4.2 to form square S4 and S6.1 and S6.2 (S6) and S8.1 and S8.2 (S8). Press seams.</p>	
<p>7. Stitch blocks S1, S2 and S3 together to form Row 1.</p>	
<p>8. Repeat to form Row 2 and Row 3.</p>	
<p>9. Stitch rows together to form a square. Press seams.</p>	

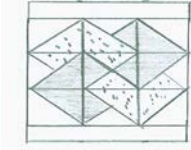
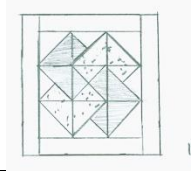
10. Stitch a dark strip (25 cm x 4 cm) to the top edge of the square. Press seam. Stitch a dark strip to the bottom edge of the square. Press.	10. 
11. Stitch dark strips to right and left sides of square. Press.	11. 
12. Place calico squares on table, place batting on top, place patchwork square on batting, pin and baste.	
13. Quilt, trim raw sides of square.	See diagram of completed square on page 21

PRACTICAL EXAMINATION 2: 3 HOURS

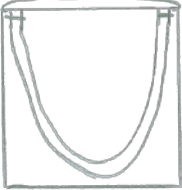
14. Place square on table, right side up. Place back piece on front piece, right sides facing. Stitch side and bottom seams. Press, turn over.	
15. Place lining squares on each other, right sides facing and stitch side seams. Press.	
16. Fold the two 70 x 8 cm strips in half lengthwise. Press and stitch in the length. Turn over to form handles.	
17. Pin handles to bag as shown in illustration.	17. 
18. Place lining over bag, right sides facing and stitch top seam. Press. Turn over	
19. Hand-stitch bottom seam of lining. Turn lining into bag.	

COMPLETED SQUARE

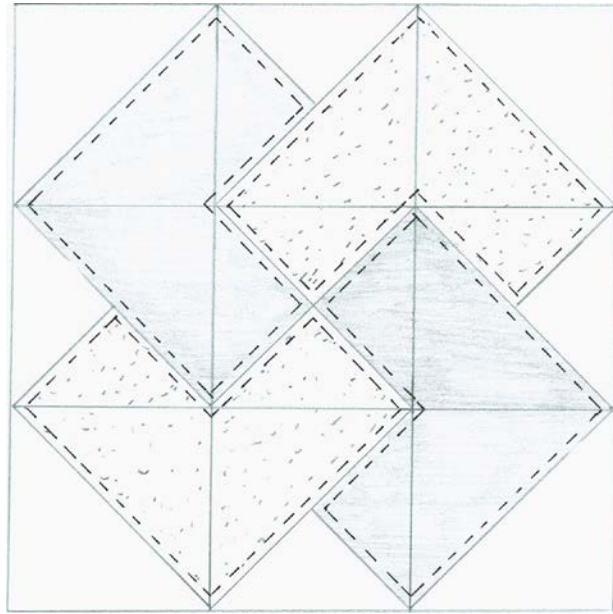

TEMPLATES

