



basic education

Department:
Basic Education
REPUBLIC OF SOUTH AFRICA

ELECTRICAL TECHNOLOGY: DIGITAL ELECTRONICS

EXAMINATION GUIDELINES

GRADE 12

2021

These guidelines consist of 17 pages.

TABLE OF CONTENTS

	Page
1. INTRODUCTION	3
2. ASSESSMENT IN GRADE 12	4
3. ELABORATION OF CONTENT FOR GRADE 12 (CAPS)	6
4. PREPARING LEARNERS FOR THE NSC: ELECTRICAL TECHNOLOGY	12
5. FORMULA SHEET: DIGITAL ELECTRONICS	17
6. CONCLUSION	17

1. INTRODUCTION

The *Curriculum and Assessment Policy Statement (CAPS)* for Electrical Technology: Digital outlines the nature and purpose of the subject Electrical Technology. This guides the philosophy underlying the teaching and assessment of the subject in Grade 12.

The purpose of these Examination Guidelines is to:

- Provide clarity on the depth and scope of the content to be assessed in the Grade 12 National Senior Certificate (NSC) Examination in Electrical Technology.
- Assist teachers to adequately prepare learners for the NSC examinations.

This document deals with the final Grade 12 external examinations. It does not deal in any depth with the School-based Assessment (SBA), Performance Assessment Tasks (PATs) or final external practical examinations as these are clarified in a separate PAT document which is updated annually.

These Examination Guidelines should be read in conjunction with:

- *The National Curriculum Statement (NCS) Curriculum and Assessment Policy Statement (CAPS): Electrical Technology*
- *The National Protocol of Assessment: An addendum to the policy document, the National Senior Certificate: A qualification at Level 4 on the National Qualifications Framework (NQF), regarding the National Protocol for Assessment (Grades R–12)*
- The national policy pertaining to the programme and promotion requirements of the National Curriculum Statement, Grades R–12

2. ASSESSMENT IN GRADE 12

2.1 Structure/Format of the question paper:

QUESTION	TOPIC	MARKS	TIME
GENERIC – ALL			
1	Multiple-choice Questions	15	14 min.
2	Occupational Health and Safety	10	9 min.
GENERIC – DIGITAL ELECTRONICS AND ELECTRONICS			
3	Switching Circuits	50	45 min.
4	Semiconductor Devices	20	17 min.
SPECIFIC			
5	Digital and Sequential Devices	55	50 min.
6	Microcontrollers	50	45 min.
TOTAL		200	180 min.

2.2 Cognitive levels

Bloom's Taxonomy consists of six levels, as shown below.

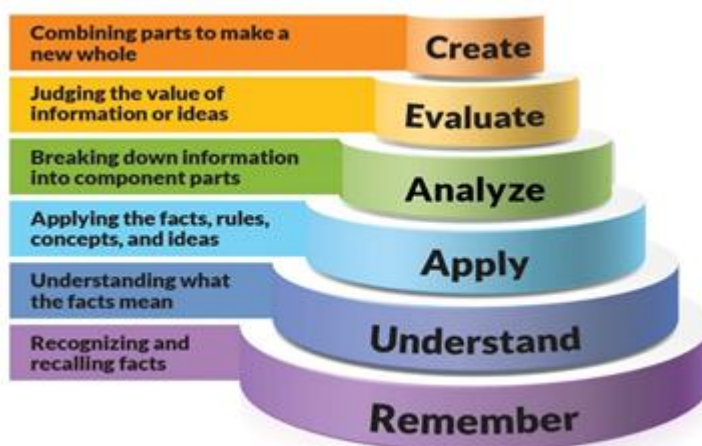

DESCRIPTION OF COGNITIVE LEVEL	LEVEL	EXPLANATION	SKILLS DEMONSTRATED	ACTION VERBS
CREATING	4	The learner creates new ideas and information using the knowledge previously learned or at hand. At the extended abstract level, the learner makes connections, not only within the given subject area, but also beyond it and generalises and transfers the principles and ideas underlying the specific instance. The learner works with relationships and abstract ideas.	<ul style="list-style-type: none"> • Generating • Planning • Producing • Designing • Inventing • Devising • Making 	devise, predict, invent, propose, construct, generate, make, develop, formulate, improve, plan, design, produce, forecast, compile, originate, imagine

Examination Guidelines

DESCRIPTION OF COGNITIVE LEVEL	LEVEL	EXPLANATION	SKILLS DEMONSTRATED	ACTION VERBS
EVALUATING	4	The learner makes decisions based on in-depth reflection, criticism and assessment. The learner works at the extended abstract level.	<ul style="list-style-type: none"> • Checking • Hypothesising • Critiquing • Experimenting • Judging • Testing • Detecting • Monitoring 	combine, integrate, modify, rearrange, substitute, compare, prepare, generalise, rewrite, categorise, combine, compile, reconstruct, organise, justify, argue, prioritise, judge, rate, validate, reject, appraise, rank, decide, criticise
ANALYSING	3	The learner appreciates the significance of the parts in relation to the whole. Various aspects of the knowledge become integrated, the learner shows a deeper understanding and the ability to break down a whole into its component parts. Elements embedded in a whole are identified and the relations among the elements are recognised.	<ul style="list-style-type: none"> • Organising • Comparing • Deconstructing • Attributing • Outlining • Finding • Structuring • Integrating 	analyse, separate, order, explain, connect, classify, arrange, divide, compare, select, infer, break down, contrast, distinguish, draw, illustrate, identify, outline, point out, relate, question, appraise, argue, defend, debate, criticise, probe, examine, investigate, experiment
APPLYING	2	The learner has the ability to use (or apply) knowledge and skills in other familiar situations and new situations.	<ul style="list-style-type: none"> • Implementing • Carrying out • Using • Executing 	apply, demonstrate, calculate, complete, illustrate, show, solve, examine, modify, relate, change, classify, experiment, discover, construct, manipulate, prepare, produce, draw, make, compile, compute, sequence, interpret
UNDERSTANDING AND ROUTINE APPLICATIONS		The learner grasps the meaning of information by interpreting and translating what has been learned.	<ul style="list-style-type: none"> • Exemplifying • Comparing • Explaining • Inferring • Classifying 	summarise, describe, interpret, calculate, contrast, associate, distinguish, estimate, differentiate, discuss, extend, comprehend, convert, explain, give example, rewrite, infer, review, observe, give main idea
REMEMBERING	1	The learner is able to recall, remember and restate facts and other learned information.	<ul style="list-style-type: none"> • Recognising • Listing • Describing • Identifying • Retrieving • Recalling • Naming 	list, define, tell, describe, identify, show, know, label, collect, select, reproduce, match, recognise, examine, quote, name

BASIC SKILLS LINKED TO THE SUBJECT:

The following skills are measured in the question paper. Visibility of these skills gives an indication of the overall skills required in the subject:

- Ability to follow instructions
- Identifying labels/labelling/making drawings/diagrams/schematic representations
- Plotting and interpretation of graphs/data
- Working out and interpreting calculations ,
- Organising/Recording and categorising data
- Extraction and/or manipulation and/or evaluation of data
- Explaining functional operation of circuits and/or components

NOTE:

CALCULATIONS	WAVEFORMS/FLOWCHARTS/CIRCUITS
Generally the criteria used for calculations are as follows: <ul style="list-style-type: none"> • Correct formula • Substitution of values • Simplifying of values • Answer and correct units 	Waveforms will be assessed according to the following criteria: <ul style="list-style-type: none"> • Type of waveform (input/output) • Correct labelling • Correct plotting of values (correct values, proportional plotting) • Labelling and units on Y-axis • Labelling and units on X-axis • Phase relationship

3. ELABORATION OF CONTENT FOR GRADE 12 (CAPS)

TOPIC	PRESCRIBED CONTENT	MARKS
Multiple-choice	Covers all content	15
Occupational health and safety	OHS Act, 1993 (Act 85 of 1993) <ul style="list-style-type: none"> • Definitions • Purpose of the Act • General duties of employers to their employees • General duties of employers and self-employed persons to persons other than their employees • General duties of manufacturers and others regarding articles and substances for use at work • Duty to inform • General duties of employees at work • Duty not to interfere with, damage or misuse devices/items • Functions of health and safety representatives • Report to inspector regarding certain incidents • Victimisation forbidden • Offences, penalties and special orders of court Safety Revision <ul style="list-style-type: none"> • Unsafe actions • Unsafe conditions • Dangerous practices • Risk analysis • Human rights in the workplace • Work ethics • Revision of emergency procedures (Grade 10) 	10

<p>Switching and control circuits</p>	<p>Principle of operation of switching circuits using operational amplifiers and timers</p> <p>NOTE:</p> <ul style="list-style-type: none"> • In multivibrators use 741 op amp and 555 timer • In Schmitt trigger, comparator, summing amplifier, differentiator and integrator use only the 741 op amp <p>Multivibrators</p> <ul style="list-style-type: none"> • Bistable multivibrator <ul style="list-style-type: none"> ➤ Circuit diagram, function of components and operation (identify, draw and explain) ➤ Measurements and drawing of input and output waveforms • Monostable multivibrators <ul style="list-style-type: none"> ➤ Circuit diagram, function of components and operation (identify, draw and explain) ➤ Measurements and drawing of input and output waveforms • Astable multivibrators <ul style="list-style-type: none"> ➤ Circuit diagram, function of components and operation (identify, draw and explain) ➤ Measurements and drawing of input and output waveforms • Schmitt trigger <ul style="list-style-type: none"> ➤ Circuit diagram, function of components and operation (identify, draw and explain) ➤ Output waveform in relation to the input waveform as displayed on an oscilloscope (identify, draw and explain) <p>Comparator and summing amplifier</p> <ul style="list-style-type: none"> • Circuit diagram, function of components and operation (identify, draw and explain) • Output waveform in relation to the input waveform as displayed on an oscilloscope (identify, draw and explain) • Calculations: <ul style="list-style-type: none"> - $V_{out} = V_{in} \times Gain$ - $V_{out} = V_{in1} \left(\frac{R_f}{R_{in1}}\right) + V_{in2} \left(\frac{R_f}{R_{in2}}\right) + \dots + V_{inN} \left(\frac{R_f}{R_{inN}}\right)$ • Measurements of input and output waveforms <p>Differentiator and integrator</p> <ul style="list-style-type: none"> • Circuit diagram, function of components and operation (identify, draw and explain) • Output waveform in relation to the input waveform as displayed on an oscilloscope (identify, draw and explain) • Influence of time constant on the output waveform (identify, draw and explain) 	<p>50</p>
--	---	-----------

Semiconductor devices	<p>Introducing integrated circuits</p> <p>Integrated circuits – the 741 op amp</p> <ul style="list-style-type: none"> • Basic construction, symbols, functional operation • Typical operating voltages • Characteristics of an ideal op amp and application as an amplifier • Gain: open-loop and closed-loop gain • Application as an inverting amplifier • Application as a non-inverting amplifier <p>Calculations</p> <ul style="list-style-type: none"> • Inverting Amplifier Output voltage $V_{OUT} = V_{IN} \times \left(-\frac{R_F}{R_{IN}}\right)$ Gain $A_V = \frac{V_{OUT}}{V_{IN}} = -\left(\frac{R_F}{R_{IN}}\right)$ • Non-inverting Amplifier Output voltage $V_{out} = V_{in} \left(\frac{R_f}{R_{in}} + 1\right)$ Gain $A_V = \frac{V_{OUT}}{V_{IN}} = \left(1 + \frac{R_F}{R_{IN}}\right)$ <p>Integrated Circuits – the 555 timer</p> <ul style="list-style-type: none"> • Basic construction, symbols, functional operation of the 555 timer • Characteristics curve and typical operating voltages • Application as a timer 	20
Digital and sequential devices	<p>Decoders and encoders</p> <ul style="list-style-type: none"> • Seven-segment displays and decoder/driver <ul style="list-style-type: none"> ➤ Block diagrams of encoders and decoders including BCD to 7-segment display decoder • LCD/LED displays and drivers <ul style="list-style-type: none"> ➤ LED modes of connection ➤ LCD principle of operation ➤ 7-segment display driver – basic construction, wiring diagram and block diagram <p>Elementary principles of combination circuits without memory elements</p> <ul style="list-style-type: none"> • Functional principles, circuit diagram (logic circuit) and use of: <ul style="list-style-type: none"> ➤ Half-adder ➤ Full adder ➤ 3- and 4-bit parallel binary adder <p>Elementary principles of memory elements</p> <ul style="list-style-type: none"> • Application of logic gates as the building blocks for memory elements: <ul style="list-style-type: none"> ➤ RS and the clocked RS latch <ul style="list-style-type: none"> ❖ Logic gate composition ❖ Truth table 	

Examination Guidelines

- ❖ Block diagram symbol
- ❖ Operation
- J-K flip-flop and clocked J-K latch
 - ❖ Logic gate composition
 - ❖ Truth table
 - ❖ Block diagram symbol
 - ❖ Operation
- D flip-flop and clocked D latch
 - ❖ Logic gate composition
 - ❖ Truth table
 - ❖ Block diagram symbol
 - ❖ Operation

The operation of RS, J-K and D-type flip-flops should be thoroughly treated through explanation and truth table. Learners should be given daily assessment on flip-flops.

Elementary principles of counters

Logic gate composition, truth table, block diagram symbol, operation and timing diagrams of the following 3- and 4-stage counters:

- Ripple counters
- Synchronous counters
- Asynchronous counters
- Up/Down counters
- Self-stopping counters
- Application of counters:
 - Counters as frequency dividers
 - Decade counter
 - Binary-coded decimal counter

The operation of counters should be thoroughly treated through explanation and demonstrations. Learners should be given daily assessment on counters.

Elementary principles of registers

Circuit diagrams of the following shift registers:

- Shift registers – serial load shift register (serial input, serial output); SISO
- Serial input, parallel output; SIPO
- Shift registers – parallel load shift register
- Parallel input, serial output; PISO
- Parallel input, parallel output; PIPO

The operation of registers should be thoroughly treated through explanation and demonstrations. Learners should be given daily assessment on registers.

Micro - controllers	<p>Introduction to microcontrollers</p> <ul style="list-style-type: none">• History of microcontrollers• Uses of microcontrollers• Advantages of microcontrollers <p>Hardware of microcontrollers</p> <ul style="list-style-type: none">• Block diagram of a microcontroller• Operation of a microcontroller• Basic function and concepts of microcontrollers• What is a <i>microcontroller</i>?• Difference between a <i>microcontroller</i> and a <i>microprocessor</i>• A digital IC that can be programmed to control a process• Discreet logic vs. integrated logic devices <p>Parts of a microcontroller – concepts only</p> <ul style="list-style-type: none">• CPU with registers<ul style="list-style-type: none">➤ Definitions and operation of the different types of registers• Memory<ul style="list-style-type: none">➤ Definitions and operation of the different types of memories (RAM and ROM)• Input/output pins• Timers<ul style="list-style-type: none">➤ Definitions and operation• Analog to digital converters<ul style="list-style-type: none">➤ Definitions and operation <p>Communication in a microcontroller</p> <ul style="list-style-type: none">• What is meant with <i>communication in a microcontroller</i>?<ul style="list-style-type: none">➤ Definitions of the different busses➤ Block diagram of the bus system➤ Definitions of the protocols➤ Block diagram and definitions of the types of protocols (simplex and duplex)➤ Serial vs. parallel communication➤ Block diagrams, differences and definitions of the two types of communication (serial and parallel)➤ Block diagrams, differences and definitions of the two types of communication (asynchronous and synchronous)• Communication peripherals<ul style="list-style-type: none">➤ Block diagrams, differences, operation and definitions of the different types:<ul style="list-style-type: none">❖ Serial communication interface (SCI) or universal asynchronous receiver transmitter (UART)❖ Serial peripheral interface (SPI)❖ Inter-integrated bus (I2C)❖ Communication protocols➤ Block diagrams, differences, operation, description of pin codes and definitions of the different types:<ul style="list-style-type: none">➤ RS-232➤ RS-485	
----------------------------	--	--

Examination Guidelines

	<p>Software of microcontrollers</p> <ul style="list-style-type: none"> • Definition of an <i>algorithm</i> • Definition of a <i>program</i> • Relationship between algorithms and flowcharts • Instruction set/Flow diagram • Definition of a <i>flow diagram</i> • Data flow diagram symbols in PICAXE • Instructions and conventions • Data flow lines • Legal vs. illegal data flows • Conditional statement (IF statement) • Looping (repetition) • Definition of <i>debugging</i> <p>PICAXE</p> <ul style="list-style-type: none"> • Using PICAXE programming software • Using Logicator or similar flowchart software to program PICAXE using the following functions: <ul style="list-style-type: none"> ➤ Input/outputs ➤ Analogue to digital conversion ➤ Timers ➤ Counters • Tutorials • Simulating before programming • Debugging a program • Interface cable (USB or RS232) • Programming the PICAXE <ul style="list-style-type: none"> ➤ Uploading and downloading programs to and from the PICAXE microcontroller ➤ Worksheets with different scenarios should be given to practise drawing flow diagrams ➤ All decision elements should have YES/NO at the correct place 	
		50
		200

4. PREPARING LEARNERS FOR THE NSC: ELECTRICAL TECHNOLOGY

Learners do not intuitively know how to answer a question paper successfully. Teachers need to prepare learners to have the skills needed to negotiate a question paper successfully.

This preparation process starts in Grade 10 and culminates in Grade 12. Learners need to be coached in some of the following skills, which will help them in answering the question paper effectively:

Manipulation of formulae: The learners must learn how to use the standard formula, manipulate the formula correctly, correctly substitute values and remember to always add a value/unit with an answer.

Prefixes and units: Learners must have a clear understanding of the conversion and uses of units and abbreviations, such as kilo, milli, micro, nano, etc. Teachers should drill learners on this skill.

Learners must be taught on how to approach a question paper and ANSWER BOOK.

Planning the answers: Learners must know how to answer in a chronological order of sequence and know how much space should be taken up by a typical answer. Do not break questions up and answer it haphazardly out of order. Ensure the numbering convention in the question paper is followed in the ANSWER BOOK.

Open spaces in the ANSWER BOOK: Teachers should encourage learners to answer ALL questions, including subquestions, and not leaving open spaces. Even when learners are unsure of the expected response, they are urged to answer to the best of their ability. This may lead their train of thoughts in the correct direction leading the learner to a correct or partially correct answer. Where learners leave an open space to proceed with the question paper, they should be taught to return to that space when the rest of the question paper is completed.

Teachers are urged to pay attention to Bloom's Taxonomy and should prepare learners to answer basic recall questions as well as more complex and intricate sentence-type questions, e.g. the paragraph-type answers such as the operation of a transformer.

Learners should be coached to regularly read questions and answers to homework and tests aloud in the class.

Teachers must encourage learners to engage in intelligent debate and discussion around subject content and on how an answer should be constructed. Learners must know how to structure their sentences in order to communicate what they are trying to say.

Learners must learn how to list facts. Answers are assessed on the principle of a single mark for a single fact.

Teachers must show the learners the difference between a sketch, a symbol and what a block diagram represents.

Below is an example of a sketch. It was drawn freehand and is a resemblance of a real-world device. Marks are awarded for drawings WITH LABELS. A drawing cannot be assessed without labels.

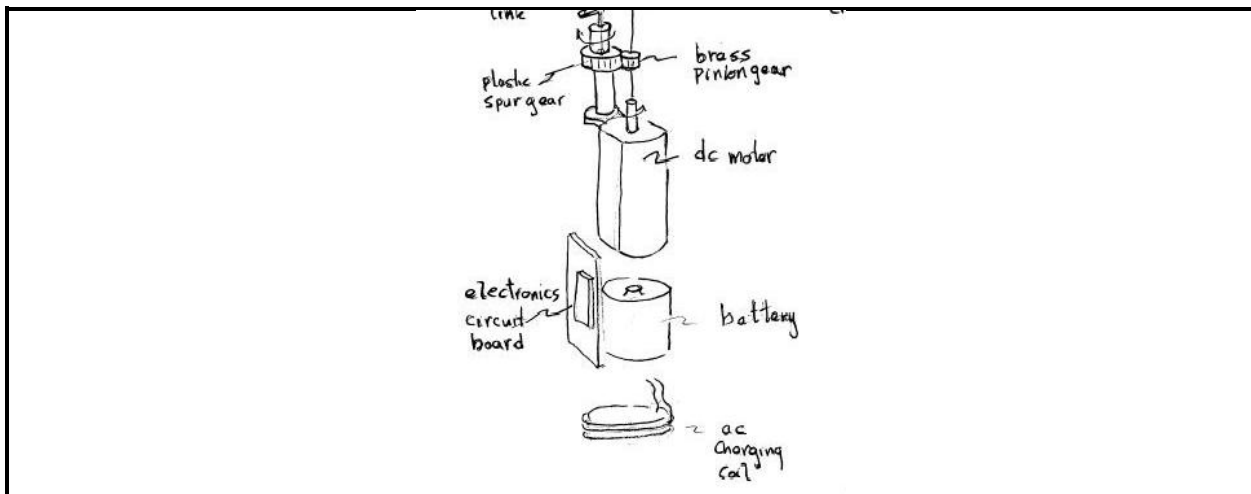

FIGURE 1: SKETCH

Symbols: Symbols are simple representations of electronic devices and relates to the theory of how the device works and not necessarily to the appearance of the device. Without labelling and a title, it cannot be marked effectively.

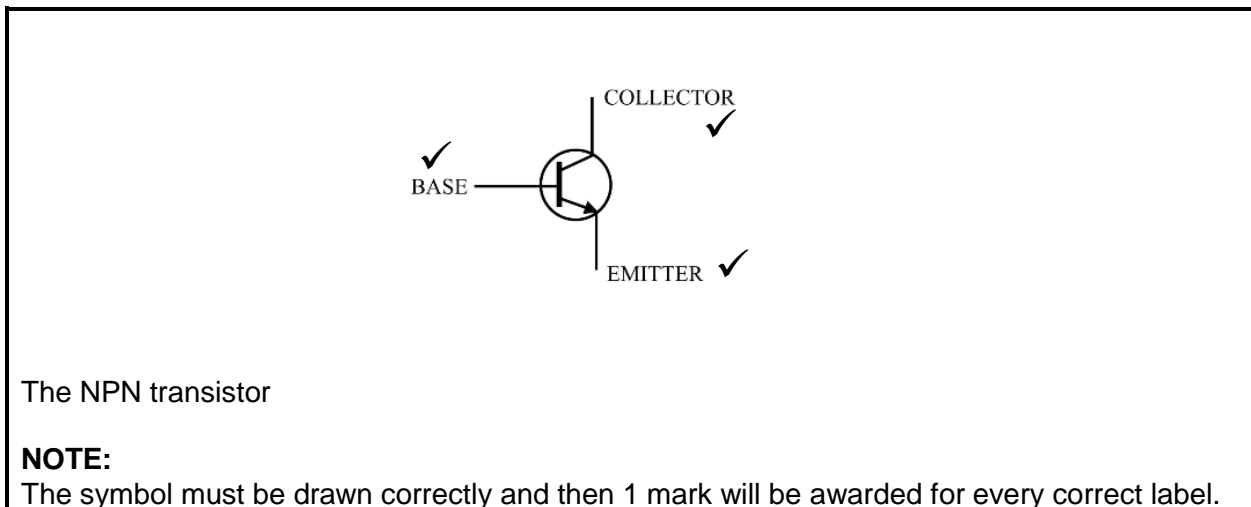

FIGURE 2: SYMBOL AND HOW IT IS MARKED

Block diagrams: Block diagrams are used extensively in Electrical Technology. It usually relates to processes and how devices operate. They are representative of the operation of a system/device and may not contain any physical resemblance to the device. Note that block diagrams may be given semi-complete, requiring the learner to fill or complete the other sections.

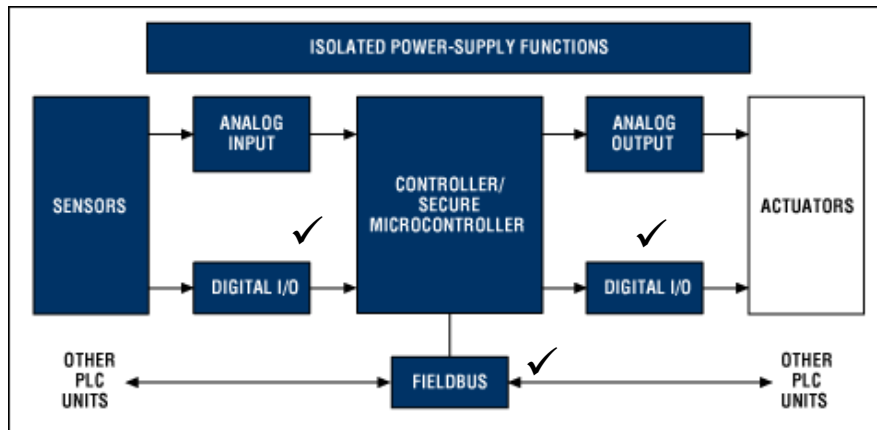

FIGURE 3: BLOCK DIAGRAM

All sketches, symbols, diagrams and waveforms must always be labelled and have a caption.

Learners must be shown how to interpret and use waveforms to support their answers.

Ladder logic: Ladder logic diagrams must be labelled and have each of the operands identified.

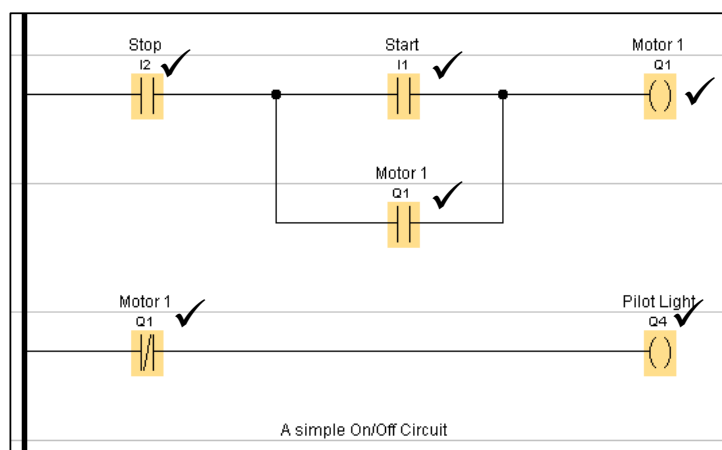

FIGURE 4: LADDER LOGIC

Sketches, diagrams and waveforms should be clear, not too small and easily interpretable.

Guard against small and illegible drawings.

Circuit diagrams: Circuit diagrams are marked on the following premise:

- The circuit or portion of the circuit must be correct.
- All components must have labels.
- Note that whole circuits or portions of a circuit may be given and interrogated.

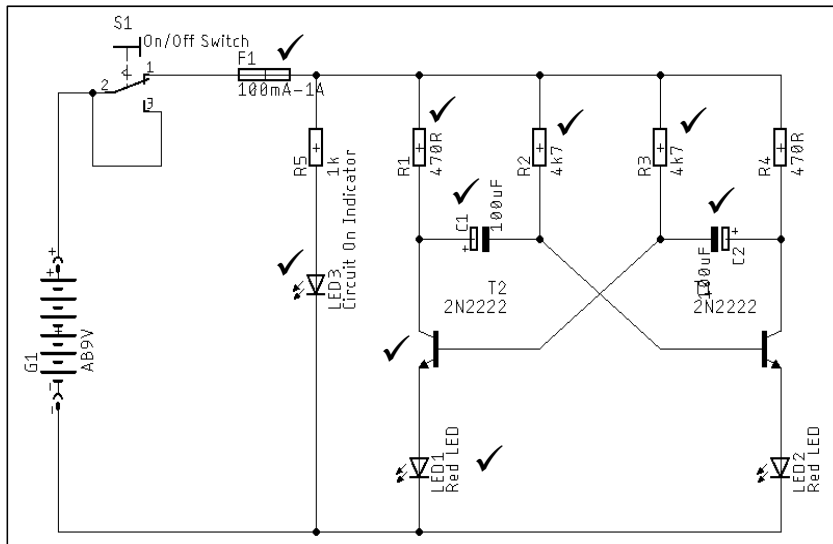

FIGURE 5: CIRCUIT DIAGRAM

Calculations:

- Calculations should be done showing ALL steps.
- Values must be placed correctly.
- Units allocated to the calculation must be shown.
- Wrong units will result in the answer being marked wrong.
- No units will result in the answer being marked wrong.

It is good practice to draw a line underneath the final answer ending it in a small arrow. This indicates that the calculation is done.

$$\begin{aligned}
 F_r &= \frac{1}{2\pi\sqrt{LC}} && \checkmark \\
 &= \frac{1}{2\pi\sqrt{0.15 \times 47 \times 10^{-6}}} && \checkmark \\
 &= \underline{59.94 \text{ Hz}} && \checkmark
 \end{aligned}$$

FIGURE 6: A CALCULATION AND HOW TO MARK IT

Lines must be drawn between questions.

Rough work should be labelled as rough work and have a line drawn through it.

Power factor (Cosθ): When using the power factor, learners should note whether they are given the power factor or the phase angle. Learners use the power factor as an angle, resulting in their answers being incorrect.

Phasor diagrams should always include an arrow showing its direction of rotation. As a phasor is a rotating vector and always rotates anticlockwise, it is required of learners to show this when doing graphical representations of phasors.

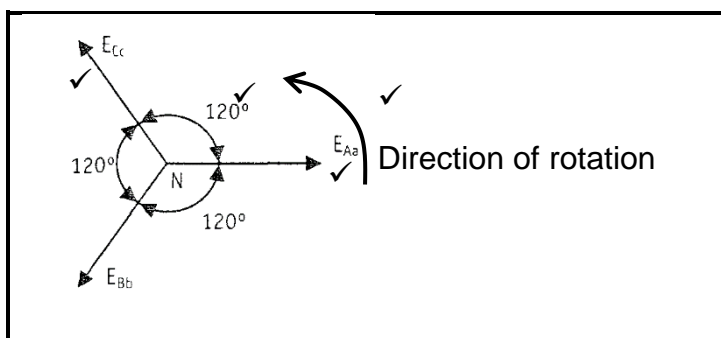

FIGURE 7: PHASOR DIAGRAM

Input and output waveforms: It is common in Electrical Technology to enquire from the learner what the result of an input waveform in a circuit may have on the output of the circuit. This is because the principle of input, process, output forms the cornerstone of how electric and electronic circuits operate.

By placing input and output waveforms directly underneath each other, in a synchronised fashion, the manner in which a circuit will affect a waveform is easily illustrated. The same applies to digital circuits.

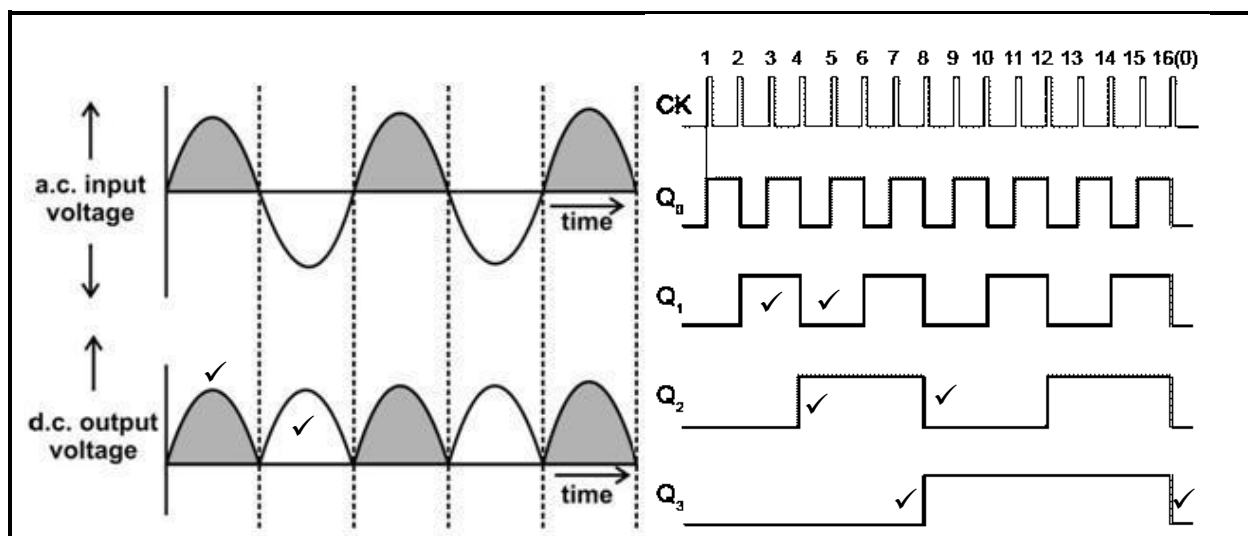

FIGURE 8: INPUT AND OUTPUT WAVEFORMS

5. FORMULA SHEET: DIGITAL ELECTRONICS

NOTE: This formula sheet is only a guide and may not contain ALL the formulae as in the prescribed textbook and/or CAPS policy document.

SEMICONDUCTOR DEVICES	SWITCHING CIRCUITS
$\text{Gain } A_V = \frac{V_{\text{OUT}}}{V_{\text{IN}}} = - \left(\frac{R_F}{R_{\text{IN}}} \right)$ $V_{\text{OUT}} = V_{\text{IN}} \times \left(- \frac{R_F}{R_{\text{IN}}} \right)$ $\text{Gain } A_V = \frac{V_{\text{OUT}}}{V_{\text{IN}}} = \left(1 + \frac{R_F}{R_{\text{IN}}} \right)$ $V_{\text{OUT}} = V_{\text{IN}} \times \left(1 + \frac{R_F}{R_{\text{IN}}} \right)$	$V_{\text{OUT}} = -(V_1 + V_2 + V_3 + \dots V_N)$ $V_{\text{OUT}} = V_{\text{IN}1} \times \left(- \frac{R_F}{R_1} \right) + V_{\text{IN}2} \times \left(- \frac{R_F}{R_2} \right) + \dots + V_{\text{IN}N} \times \left(- \frac{R_F}{R_N} \right)$

6. CONCLUSION

It is envisaged that these Examination Guidelines will serve as an instrument to strengthen and empower teachers to set valid and reliable assessment items in all their classroom activities.

This Examination Guidelines document is meant to articulate the assessment aspirations espoused in the CAPS document. It is therefore not a substitute for the CAPS document which teachers should teach to.

Qualitative curriculum coverage as enunciated in the CAPS cannot be over-emphasised.