



# basic education

---

Department:  
Basic Education  
**REPUBLIC OF SOUTH AFRICA**

**NATIONAL  
SENIOR CERTIFICATE**

**GRADE 12**

**ENGINEERING GRAPHICS AND DESIGN P1**

**FEBRUARY/MARCH 2013**

**MEMORANDUM**

**MARKS: 100**

**This memorandum consists of 7 pages.**

## ANSWERS

1	12-12-2012	1
2	THANDI	1
3	2	1
4	4 m / 4000	1
5	1 : 40	1
6	2,2 m or 2200	1
7	RED	1
8	2,75 m or 2750	1
9	SERVITUDE	1
10	GATE SWING	1
11	BUILDING LINE	1
12	SEWERAGE LINE	1
13	BOUNDARY LINE	1
14	WEST	2
15	C or 64,3	2
16	3,48 m or 3480	2
17	THE TREE OVER THE SEWERAGE LINE	2
18	134,761 m [calculation 1, answer 1, metre 1]	3
19	167,04 m <sup>2</sup> [calculation 1, answer 1, metre <sup>2</sup> 1]	3
20		3

**TOTAL: 30**

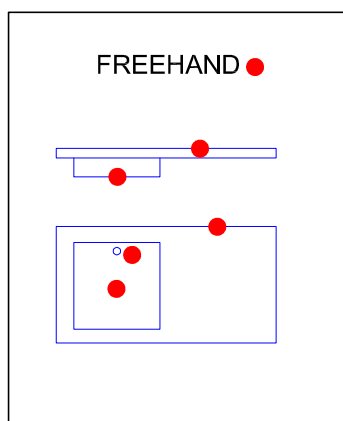

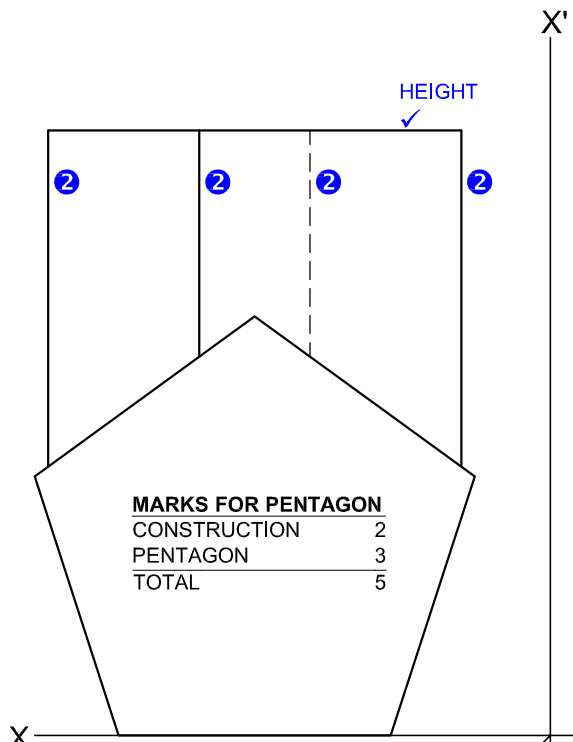
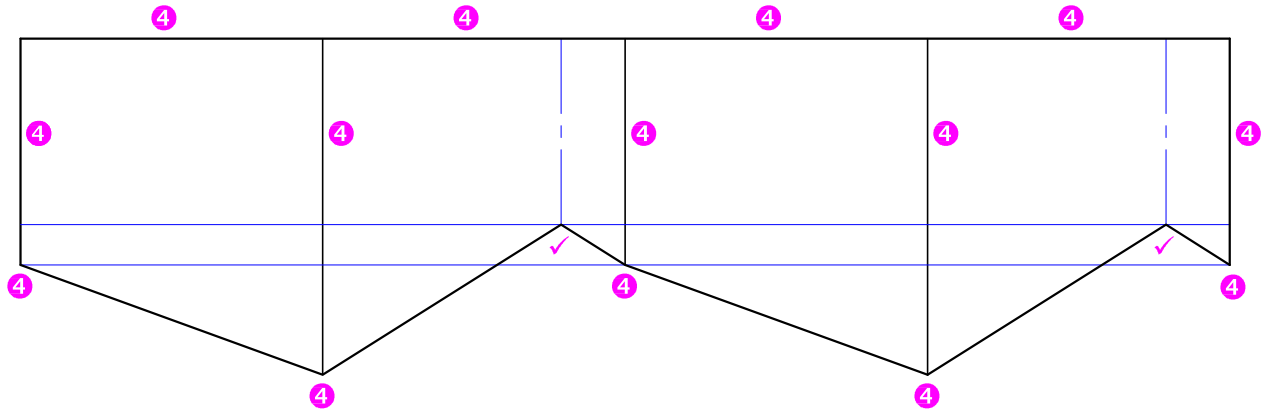

MARKS FOR PENTAGON	
CONSTRUCTION	2
PENTAGON	3
<b>TOTAL</b>	<b>5</b>

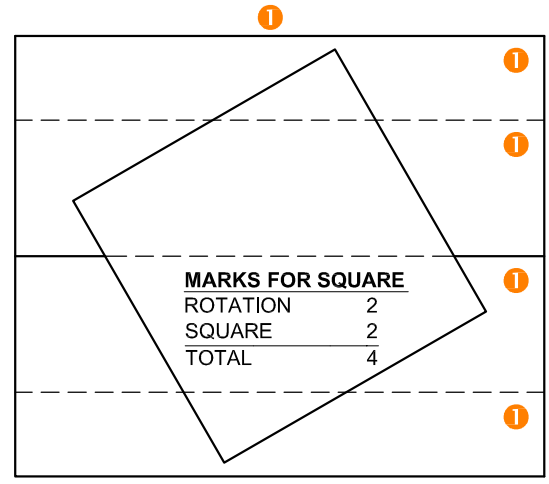
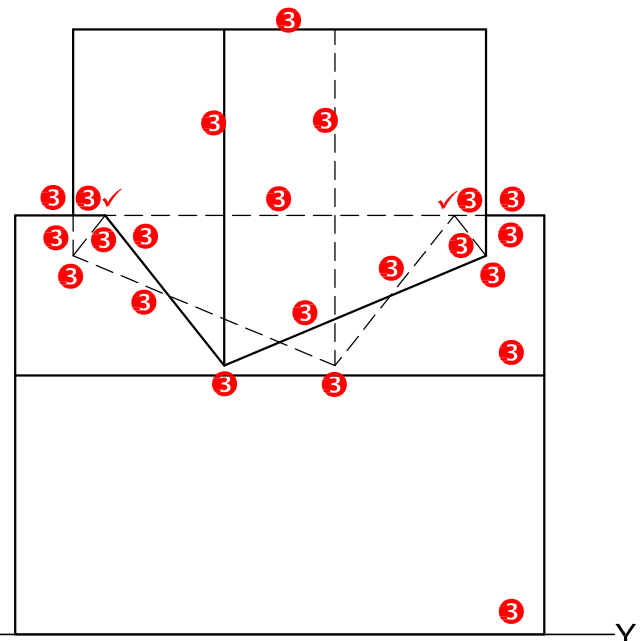

MARKS FOR SQUARE	
ROTATION	2
SQUARE	2
<b>TOTAL</b>	<b>4</b>

ASSESSMENT CRITERIA		
1	TOP VIEW	7
2	RIGHT VIEW	8
3	FRONT VIEW	13
4	DEVELOPMENT	9
<b>TOTAL</b>		<b>37</b>

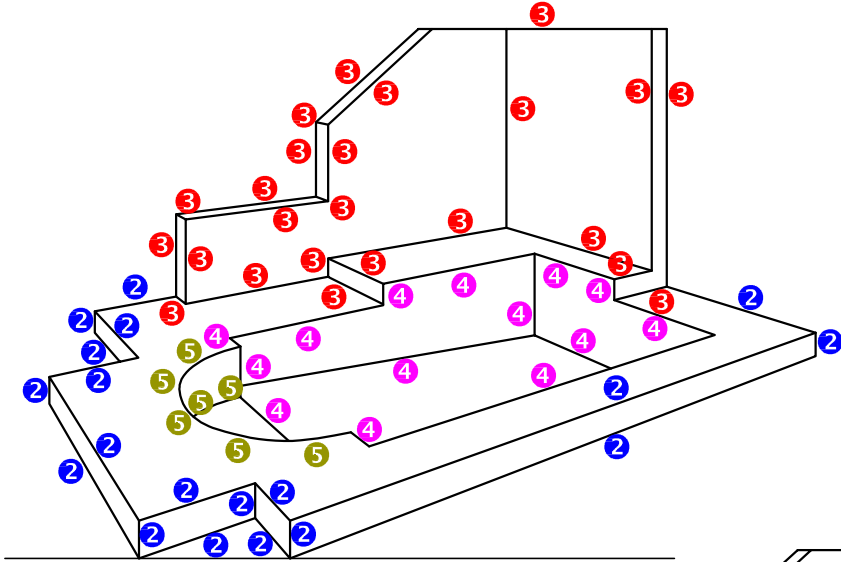
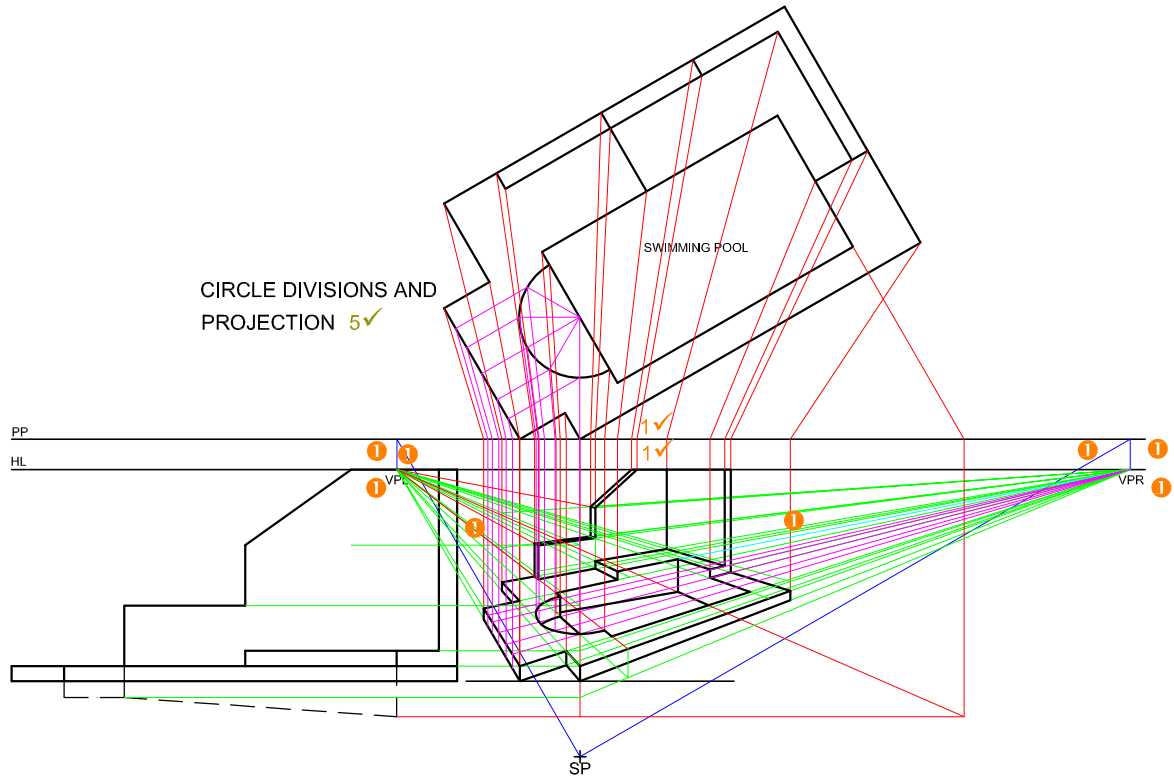

SP

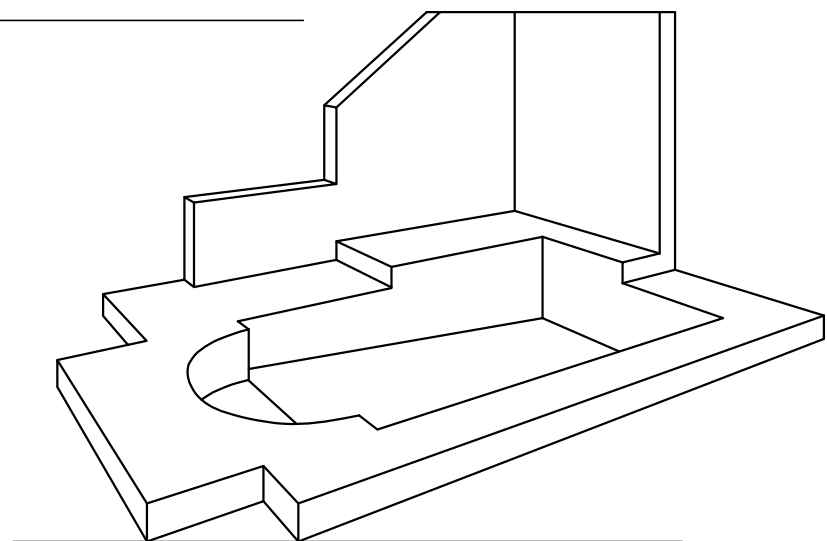

ASSESSMENT CRITERIA		
1	CONSTRUCTION + VPs	6
2	SURROUND	9½
3	WALL + STEP	12
4	SWIMMING POOL	7
5	SEMI-CIRCLE	4½
<b>TOTAL</b>		<b>39</b>

PAPER 1 QUESTION 3  
 GRADE 12  
 FEB. - MAR. 2013  
 MEMORANDUM

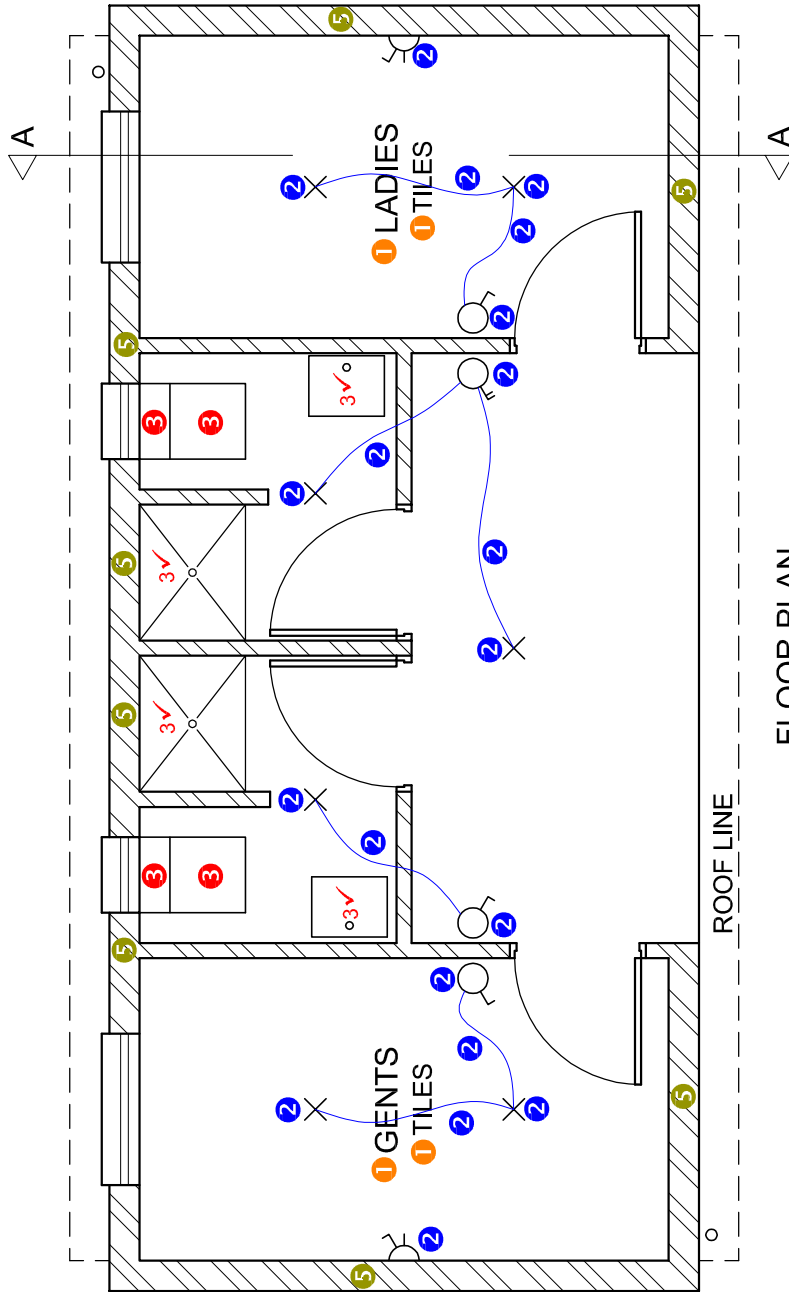

FLOOR PLAN  
SCALE 1:50

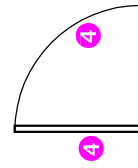

DETAIL OF MARK ALLOCATION FOR A DOOR  
(1 x 4 doors = 4)



DETAIL OF MARK ALLOCATION FOR A WINDOW  
(2½ x 4 windows = 10)

FLOOR PLAN		
1	LABELS	2
2	ELECTRICAL	10
3	FIXTURES	6
4	DOORS + WINDOWS	14
5	HATCHING	4
<b>SUBTOTAL</b>		<b>36</b>

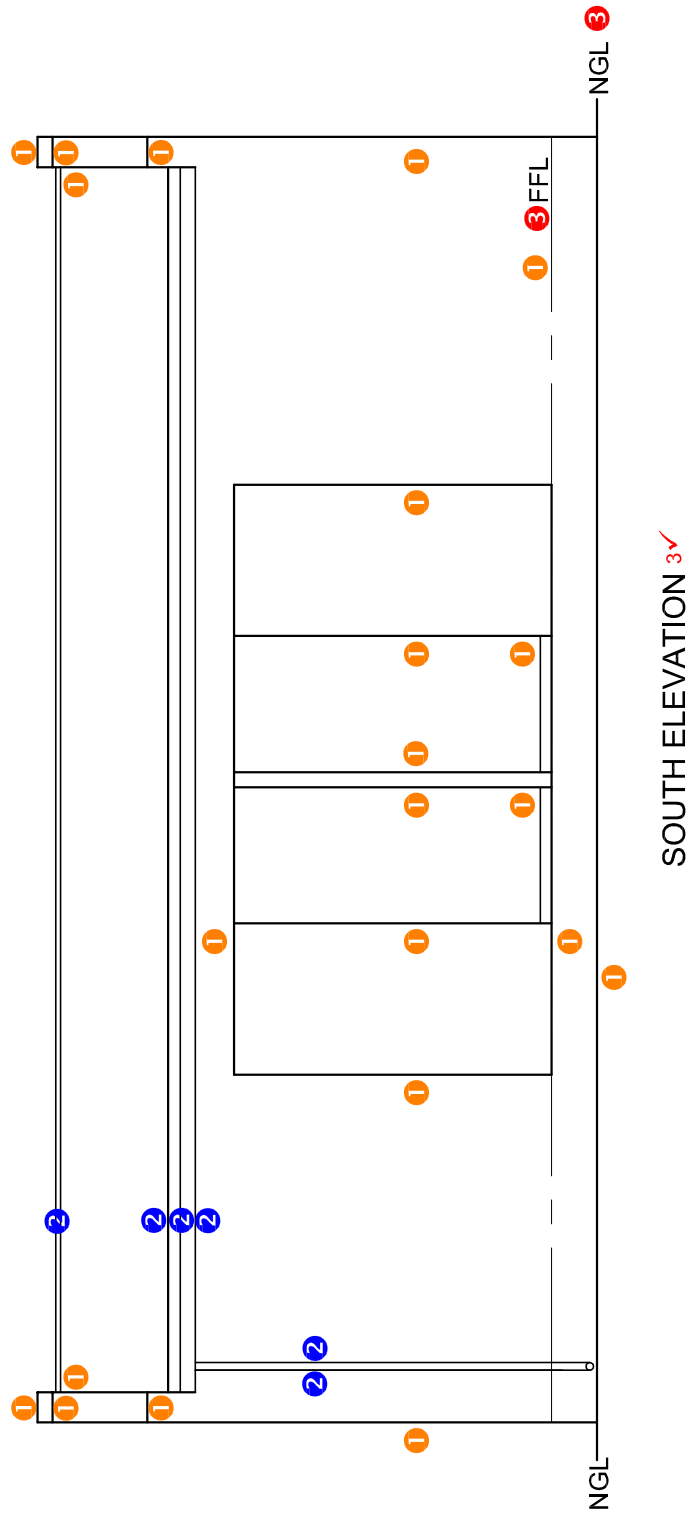

SOUTH ELEVATION <sup>3✓</sup>

SOUTH ELEVATION	
1	WALLS + FFL + DOOR + SH 11
2	ROOF + GUTTER + RWDP 3
3	LABELS 2
<b>SUBTOTAL 16</b>	

**MARK ALLOCATION**

ROOF CAP	1
ROOF SHEET	2
PURLINS	2
GUTTERS	2
RWDP	2
WALL PLATE (2 x 1/2)	1
TRUSS (4 x 1)+(2 x 1/2)	5
<b>TOTAL</b>	<b>15</b>

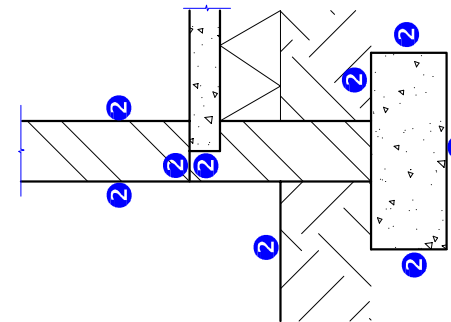
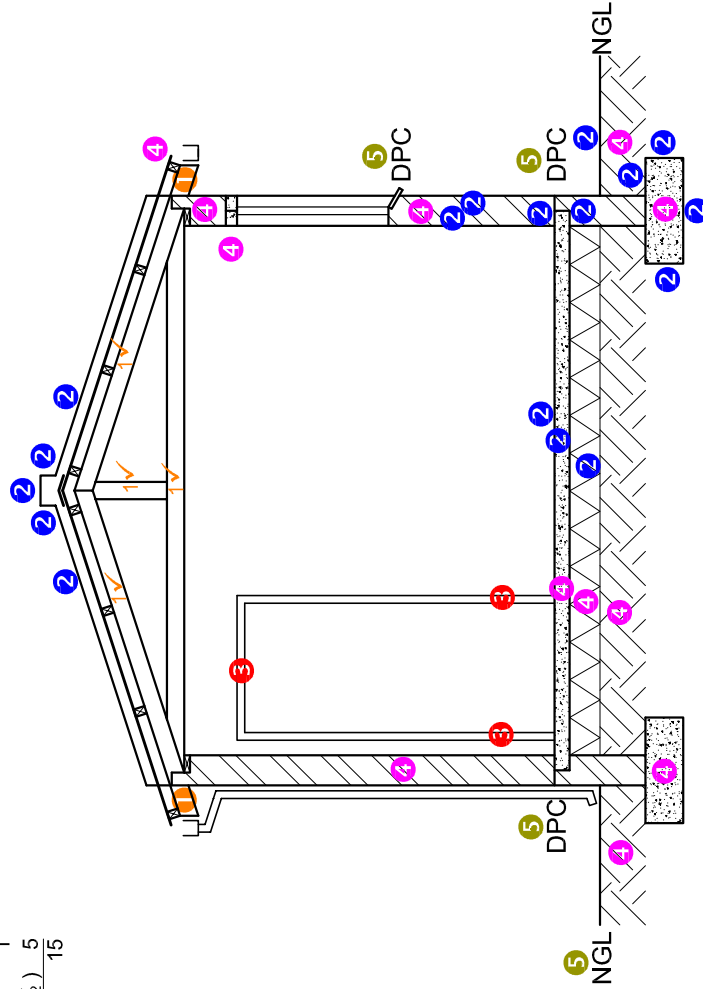

DETAIL OF MARK ALLOCATION FOR A LOAD-BEARING WALL

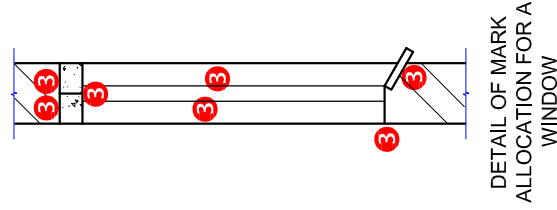

DETAIL OF MARK ALLOCATION FOR A WINDOW

SECTIONAL ELEVATION		
1	ROOF	15
2	WALLS + FLOOR + FOUNDATION	13
3	WINDOW, DOOR + FIXTURES	5
4	HATCHING	6
5	LABELS	3
<b>SUBTOTAL</b>		<b>42</b>