



# basic education

Department:  
Basic Education  
**REPUBLIC OF SOUTH AFRICA**

**NATIONAL  
SENIOR CERTIFICATE**

**GRADE 12**

**PHYSICAL SCIENCES: PHYSICS (P1)**

**EXEMPLAR 2014**

**MARKS: 150**

**TIME: 3 hours**

**This question paper consists of 16 pages and 3 data sheets.**

**INSTRUCTIONS AND INFORMATION**

1. Write your name in the appropriate space on the ANSWER BOOK.
2. This question paper consists of ELEVEN questions. Answer ALL the questions in the ANSWER BOOK.
3. Start EACH question on a NEW page in the ANSWER BOOK.
4. Number the answers correctly according to the numbering system used in this question paper.
5. Leave ONE line between two subquestions, for example between QUESTION 2.1 and QUESTION 2.2.
6. You may use a non-programmable calculator.
7. You may use appropriate mathematical instruments.
8. You are advised to use the attached DATA SHEETS.
9. Show ALL formulae and substitutions in ALL calculations.
10. Round off your final numerical answers to a minimum of TWO decimal places.
11. Give brief motivations, discussions, et cetera where required.
12. Write neatly and legibly.

**QUESTION 1: MULTIPLE-CHOICE QUESTIONS**

Four options are provided as possible answers to the following questions. Each question has only ONE correct answer. Write only the letter (A–D) next to the question number (1.1–1.10) in the ANSWER BOOK, for example 1.11 E.

- 1.1 The net force acting on an object is directly proportional to the ...
- A mass of the object.
  - B acceleration of the object.
  - C change in momentum of the object.
  - D rate of change in momentum of the object. (2)
- 1.2 An astronomer, viewing light from distant galaxies, observes a shift of spectral lines toward the red end of the visible spectrum. This shift provides evidence that ...
- A the universe is expanding.
  - B the galaxies are moving closer towards Earth.
  - C Earth is moving towards the distant galaxies.
  - D the temperature of Earth's atmosphere is increasing. (2)
- 1.3 A ball is thrown vertically upwards. Which ONE of the following physical quantities has a non-zero value at the instant the ball changes direction?
- A Acceleration
  - B Kinetic energy
  - C Momentum
  - D Velocity (2)

- 1.4 Two trolleys, **P** and **Q**, of mass  $m$  and  $2m$  respectively are at rest on a frictionless horizontal surface. The trolleys have a compressed spring between them.

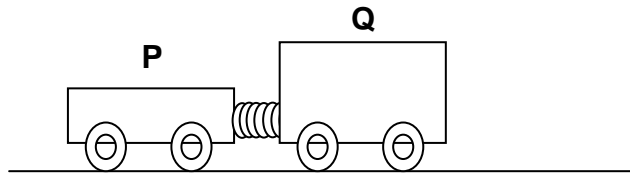

The spring is released and the trolleys move apart. Which ONE of the following statements is TRUE?

- A **P** and **Q** have equal kinetic energies.
- B The speed of **P** is less than the speed of **Q**.
- C The sum of the final kinetic energies of **P** and **Q** is zero.
- D The sum of the final momentum of **P** and **Q** is zero. (2)

- 1.5 The diagram below shows the electric field pattern due to two point charges **X** and **Y**.

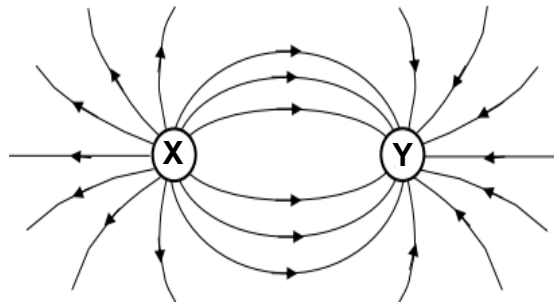

Which ONE of the following represents the charge on **X** and **Y** respectively?

	POINT CHARGE X	POINT CHARGE Y
A	Negative	Negative
B	Positive	Positive
C	Positive	Negative
D	Negative	Positive

(2)

- 1.6 Two identical metal spheres, each of mass  $m$  and separated by a distance  $r$ , exert a gravitational force of magnitude  $F$  on each other. The distance between the spheres is now HALVED.

The magnitude of the force the spheres now exerts on each other is:

- A  $\frac{1}{2}F$
- B  $F$
- C  $2F$
- D  $4F$  (2)

- 1.7 In the diagram below, a conductor placed between two magnets is carrying current out of the page.

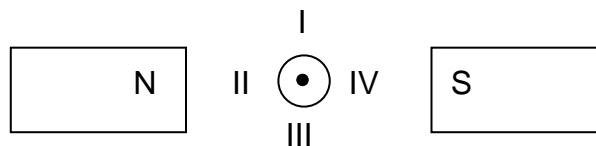

The direction of the force exerted on the conductor is towards:

- A I
- B II
- C III
- D IV (2)

- 1.8 When light of a certain frequency is incident on the cathode of a photocell, the ammeter in the circuit registers a reading.

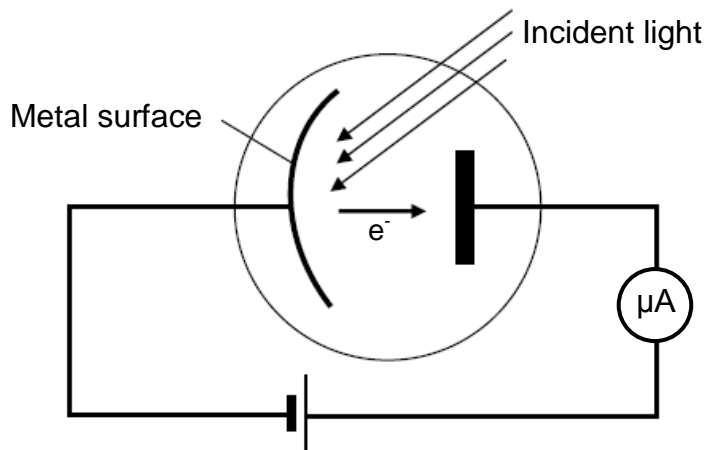

The frequency of the incident light is now increased while keeping the intensity constant. Which ONE of the following correctly describes the reading on the ammeter and the reason for this reading?

	AMMETER READING	REASON
A	Increases	More photoelectrons are emitted per second.
B	Increases	The speed of the photoelectrons increases.
C	Remains the same	The number of photoelectrons remains the same.
D	Remains the same	The speed of the photoelectrons remains the same.

(2)

- 1.9 An applied force  $F$  accelerates an object of mass  $m$  on a horizontal frictionless surface from a velocity  $v$  to a velocity  $2v$ .

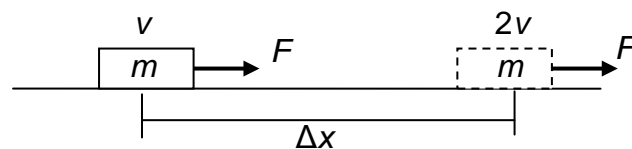

The net work done on the object is equal to ...

- A  $\frac{1}{2}mv^2$ .  
 B  $mv^2$ .  
 C  $\frac{3}{2}mv^2$ .  
 D  $2mv^2$ .

(2)

1.10 Consider the circuit diagram below.

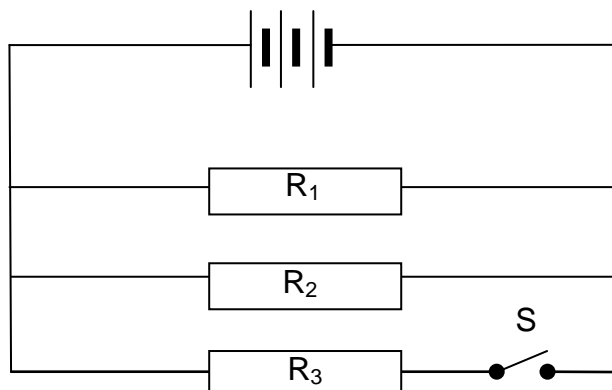

Which ONE of the following correctly describes the change in total resistance and total current when switch **S** is closed?

	<b>TOTAL RESISTANCE</b>	<b>TOTAL CURRENT</b>
A	Decreases	Decreases
B	Increases	Increases
C	Decreases	Increases
D	Increases	Decreases

(2)  
[20]

**QUESTION 2 (Start on a new page.)**

A light inelastic string connects two objects of mass 6 kg and 3 kg respectively. They are pulled up an inclined plane that makes an angle of  $30^\circ$  with the horizontal, with a force of magnitude  $F$ . Ignore the mass of the string.

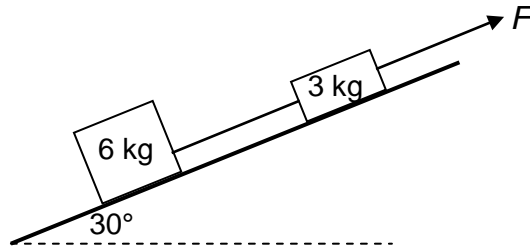

The coefficient of kinetic friction for the 3 kg object and the 6 kg object is 0,1 and 0,2 respectively.

- 2.1 State Newton's Second Law of Motion in words. (2)
- 2.2 How will the coefficient of kinetic friction be affected if the angle between the incline and the horizontal increases? Write down only INCREASES, DECREASES or REMAINS THE SAME. (1)
- 2.3 Draw a labelled free-body diagram indicating all the forces acting on the 6 kg object as it moves up the inclined plane. (4)
- 2.4 Calculate the:
- 2.4.1 Tension in the string if the system accelerates up the inclined plane at  $4 \text{ m}\cdot\text{s}^{-2}$  (5)
- 2.4.2 Magnitude of  $F$  if the system moves up the inclined plane at CONSTANT VELOCITY (6)
- 2.5 How would the tension in the string, calculated in QUESTION 2.4.1, be affected if the system accelerates up a FRICTIONLESS inclined plane at  $4 \text{ m}\cdot\text{s}^{-2}$ ? Write down only INCREASES, DECREASES OR REMAINS THE SAME. (1)
- [19]**



**QUESTION 3 (Start on a new page.)**

A ball of mass 0,5 kg is projected vertically downwards towards the ground from a height of 1,8 m at a velocity of  $2 \text{ m}\cdot\text{s}^{-1}$ . The position-time graph for the motion of the ball is shown below.

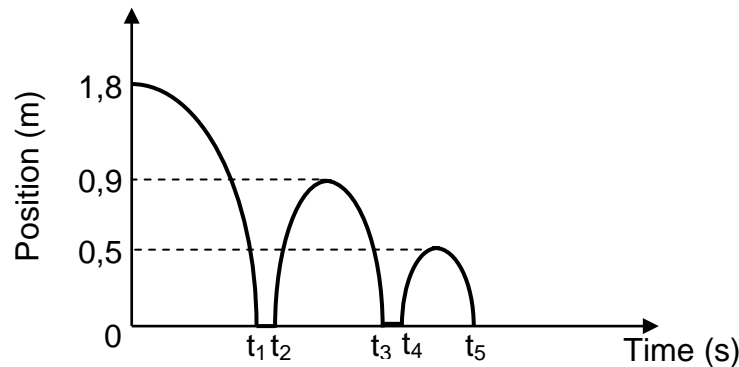

- 3.1 What is the maximum vertical height reached by the ball after the second bounce? (1)

Calculate the:

- 3.2 Magnitude of the time  $t_1$  indicated on the graph (5)
- 3.3 Velocity with which the ball rebounds from the ground during the first bounce (4)

The ball is in contact with the ground for 0,2 s during the first bounce.

- 3.4 Calculate the magnitude of the force exerted by the ground on the ball during the first bounce if the ball strikes the ground at  $6,27 \text{ m}\cdot\text{s}^{-1}$ . (4)
- 3.5 Draw a velocity-time graph for the motion of the ball from the time that it is projected to the time when it rebounds to a height of 0,9 m.

Clearly show the following on your graph:

- The time when the ball hits the ground
- The velocity of the ball when it hits the ground
- The velocity of the ball when it rebounds from the ground

(3)  
**[17]**

**QUESTION 4 (Start on a new page.)**

Two boys, each of mass  $m$ , are standing at the back of a flatbed trolley of mass  $4 m$ . The trolley is at rest on a frictionless horizontal surface.

The boys jump off simultaneously at one end of the trolley with a horizontal velocity of  $2 \text{ m}\cdot\text{s}^{-1}$ . The trolley moves in the opposite direction.

- 4.1 Write down the *principle of conservation of linear momentum* in words. (2)
- 4.2 Calculate the final velocity of the trolley. (5)
- 4.3 The two boys jump off the trolley one at a time. How will the velocity of the trolley compare to that calculated in QUESTION 4.2? Write down only GREATER THAN, SMALLER THAN or EQUAL TO. (1)
- [8]**

**QUESTION 5 (Start on a new page.)**

A  $3 \text{ kg}$  trolley is at rest on a horizontal frictionless surface. A constant horizontal force of  $10 \text{ N}$  is applied to the trolley over a distance of  $2,5 \text{ m}$ .

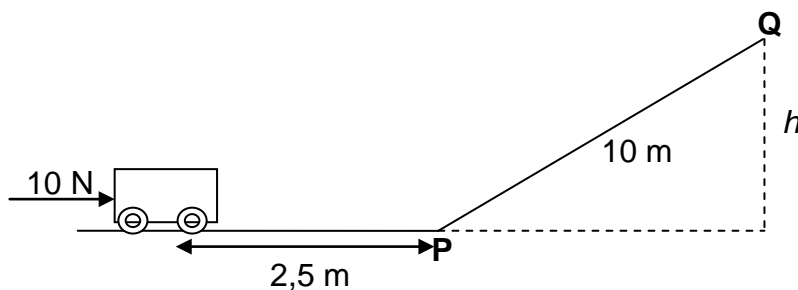

When the force is removed at point  $P$ , the trolley moves a distance of  $10 \text{ m}$  up the incline until it reaches the maximum height at point  $Q$ . While the trolley moves up the incline, there is a constant frictional force of  $2 \text{ N}$  acting on it.

- 5.1 Write down the name of a non-conservative force acting on the trolley as it moves up the incline. (1)
- 5.2 Draw a labelled free-body diagram showing all the forces acting on the trolley as it moves along the horizontal surface. (3)
- 5.3 State the WORK-ENERGY THEOREM in words. (2)
- 5.4 Use the work-energy theorem to calculate the speed of the trolley when it reaches point  $P$ . (4)
- 5.5 Calculate the height,  $h$ , that the trolley reaches at point  $Q$ . (5)
- [15]**

**QUESTION 6 (Start on a new page.)**

The siren of a stationary police car emits sound waves of wavelength 0,55 m.

With its siren on, the police car now approaches a stationary listener at constant velocity on a straight road. Assume that the speed of sound in air is  $345 \text{ m}\cdot\text{s}^{-1}$ .

- 6.1 Will the wavelength of the sound waves observed by the listener be GREATER THAN, SMALLER THAN or EQUAL TO 0,55 m? (1)
- 6.2 Name the phenomenon observed in QUESTION 6.1. (1)
- 6.3 Calculate the frequency of the sound waves observed by the listener if the car approaches him at a speed of  $120 \text{ km}\cdot\text{h}^{-1}$ . (7)
- 6.4 How will the answer in QUESTION 6.3 change if the police car moves away from the listener at  $120 \text{ km}\cdot\text{h}^{-1}$ ? Write down only INCREASES, DECREASES or REMAINS THE SAME. (1)

**[10]****QUESTION 7 (Start on a new page.)**

Three small, identical metal spheres,  $Q_1$ ,  $Q_2$  and  $Q_3$ , are placed in a vacuum. Each sphere carries a charge of  $-4 \mu\text{C}$ . The spheres are arranged such that  $Q_2$  and  $Q_3$  are each 3 mm from  $Q_1$  as shown in the diagram below.

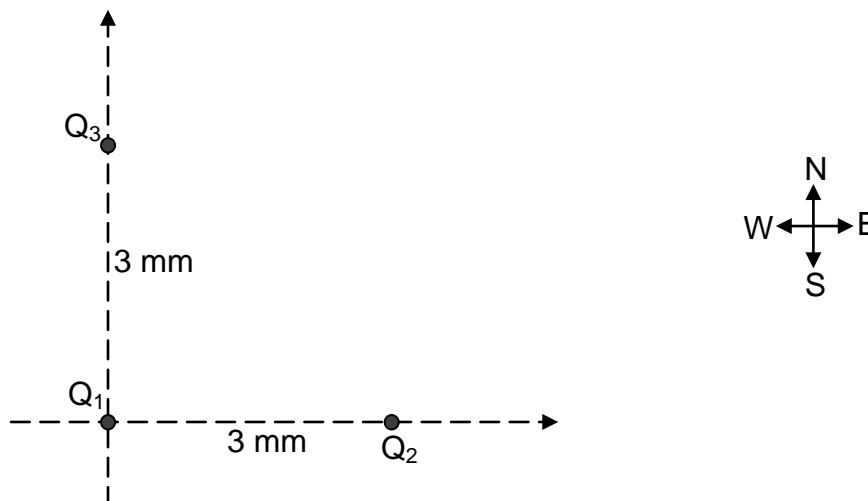

- 7.1 State Coulomb's law in words. (2)
- 7.2 Draw a force diagram showing the electrostatic forces exerted on  $Q_1$  by  $Q_2$  and  $Q_3$ . (2)
- 7.3 Calculate the net force exerted on  $Q_1$  by  $Q_2$  and  $Q_3$ . (8)

**[12]**

**QUESTION 8 (Start on a new page.)**

An isolated point charge **Q** is located in space as shown in the diagram below. Point charge **Q** contributes to an electric field as shown. Point **X** is located 3 mm away from point charge **Q**.

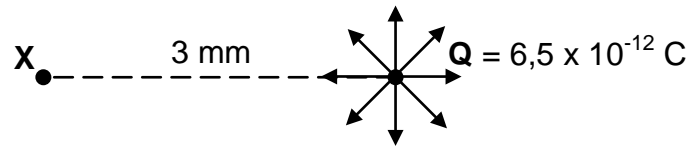

- 8.1 Define the term *electric field* at a point. (2)
- 8.2 Calculate the magnitude of the electric field at point **X**. (3)
- 8.3 Point charge **R** carrying a charge of  $+ 6,5 \times 10^{-12} \text{ C}$  is placed 3 mm away from point **X** as shown in the diagram below.

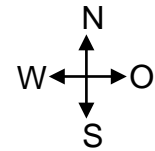
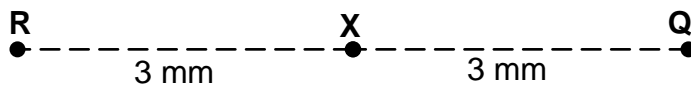

Calculate the net electric field at point **X**.

(4)  
[9]

**QUESTION 9 (Start on a new page.)**

- 9.1 In an experiment, learners use the circuit below to determine the internal resistance of a cell.

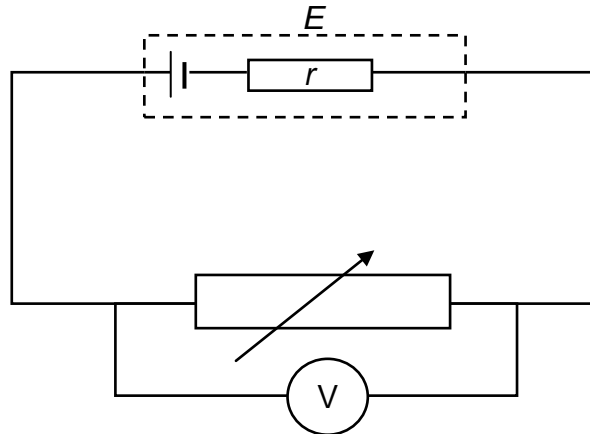

The circuit consists of a cell of emf  $E$  and internal resistance  $r$ . A voltmeter is placed across a variable resistor which can be set to *known values*  $R$ .

The equation used by the learners is:

$$\frac{1}{V} = \frac{r}{ER} + \frac{1}{E}$$

They obtain the graph below.

**Graph of  $\frac{1}{V}$  versus  $\frac{1}{R}$**

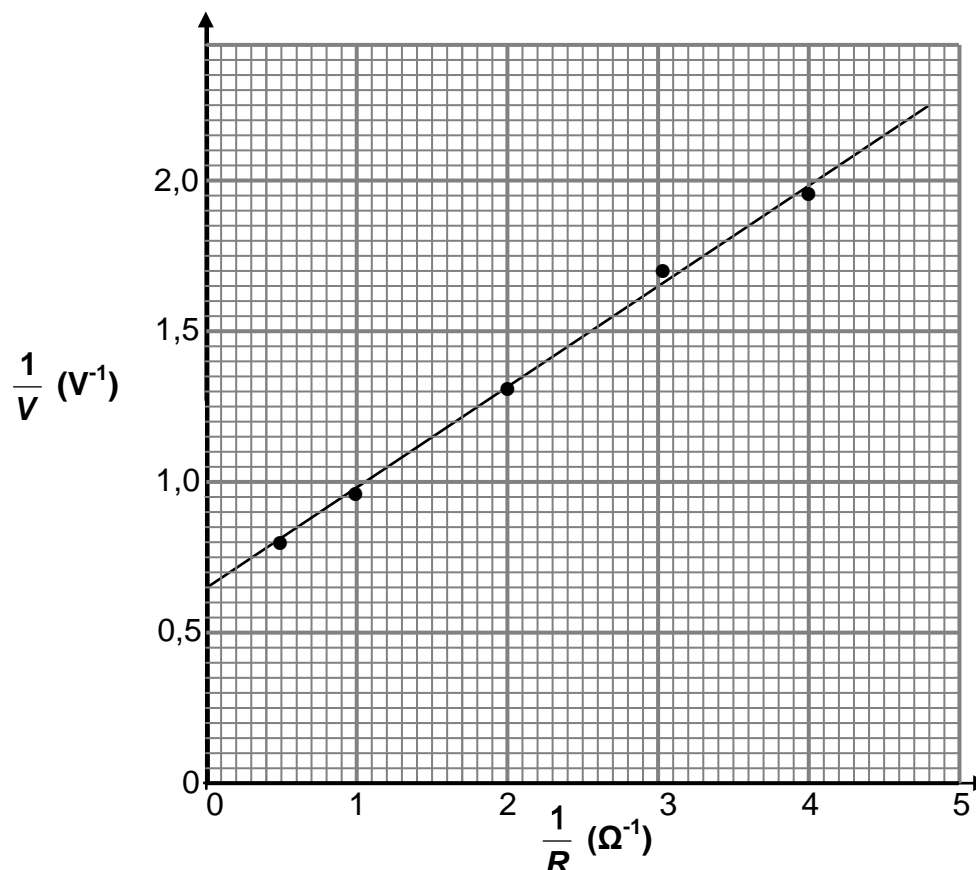

9.1.1 Write down a mathematical relationship for the slope of the graph. (1)

Use the information in the graph and calculate the:

9.1.2 Emf of the cell (2)

9.1.3 Internal resistance of the cell (3)

9.2 In the electrical circuit shown below, the battery has an emf of 6 V and an internal resistance of 1  $\Omega$ . The total external resistance of the circuit is 9  $\Omega$ .

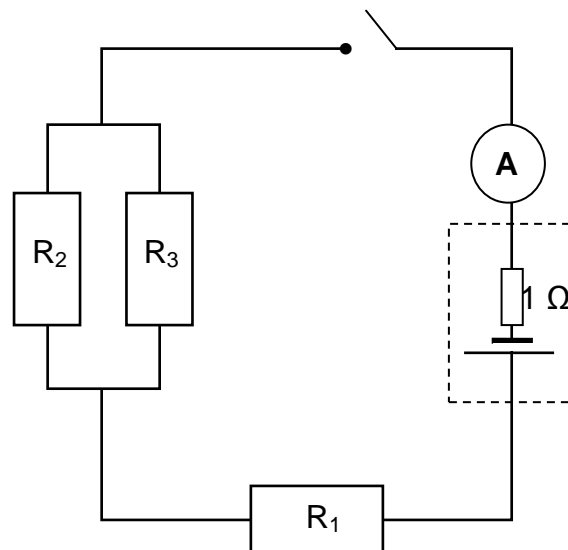

9.2.1 Calculate the current in  $R_1$  when the switch is closed. (3)

The power dissipated in resistor  $R_1$  is 1,8 W. The resistance of resistor  $R_3$  is 4 times that of resistor  $R_2$ . ( $R_3 = 4R_2$ )

9.2.2 Calculate the resistance of resistor  $R_2$ . (5)

9.3 A hair dryer operates at a potential difference of 240 V and a current of 9,5 A.

It takes a learner 12 minutes to completely dry her hair. Eskom charges energy usage at R1,47 per unit. Calculate the cost of operating the hairdryer for the 12 minutes. (1 unit = 1 kW·h)

(4)  
**[18]**

**QUESTION 10 (Start on a new page.)**

A simplified diagram of a DC generator and a graph of its output potential difference for one cycle is shown below.

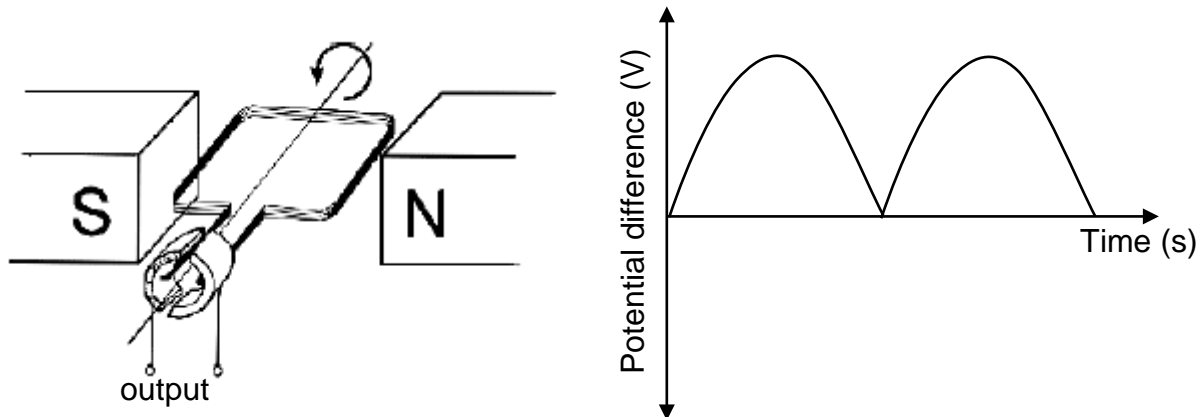

10.1 Write down ONE way in which the output of this generator can be increased. (1)

A specific change is made to the structure of the DC generator in QUESTION 10.1. The output potential difference obtained as a result of this change is shown below.

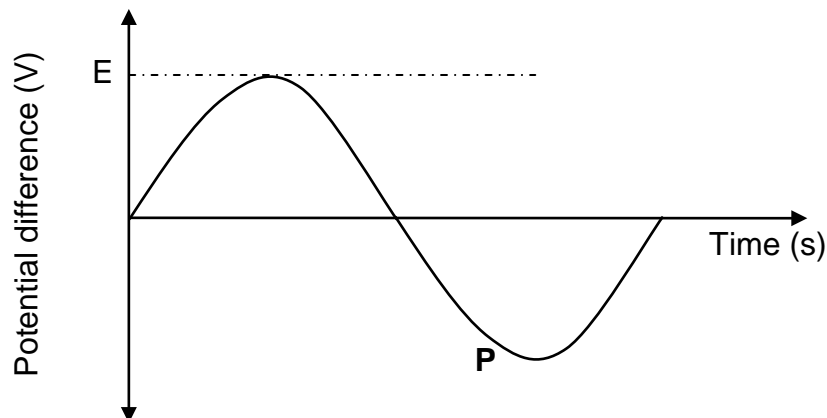

10.2 Write down the change that was made to the DC generator. (1)

10.3 Copy graph **P** into your ANSWER BOOK.

On the same set of axes, sketch the graph of the output potential difference that will be obtained when the new generator is rotated at TWICE its original speed.

Label this graph as **Q**. (2)

10.4 A certain generator operates at a maximum voltage of 340 V. A 120 W appliance is connected to the generator. Calculate the resistance of the appliance. (4)

**[8]**

**QUESTION 11 (Start on a new page.)**

Graph **P** below shows how the maximum kinetic energy of electrons emitted from the cathode of a photoelectric cell varies with the frequency of the incident radiation.

**Graph of maximum kinetic energy versus frequency**

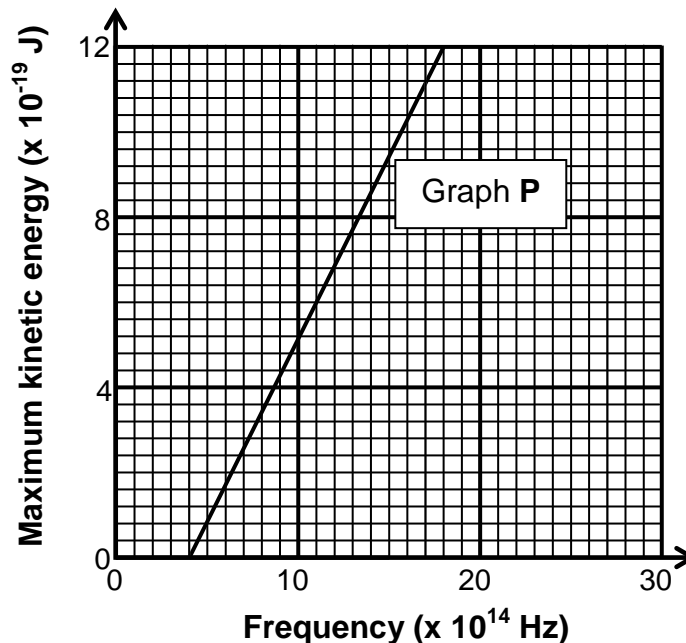

- 11.1 Define the term *work function*. (2)
- 11.2 Calculate the:
- 11.2.1 Work function of the metal used as cathode in the photocell (3)
- 11.2.2 Velocity of photoelectrons emitted when the frequency of the incident light is  $8 \times 10^{14}$  Hz (5)
- 11.3 The photocell is now replaced with another one in which the work function of the cathode is TWICE that of the metal in the first cell.
- The maximum kinetic energy versus frequency graph, **Q**, for this cathode is now drawn on the same set of axes as graph **P**.
- 11.3.1 How will the gradient of graph **Q** compare to that of graph **P**? Write down GREATER THAN, SMALLER THAN or EQUAL TO. Explain the answer. (2)
- 11.3.2 What will the value of the x-intercept of graph **Q** be? Explain how you arrived at the answer. (2)

**[14]****TOTAL: 150**



**DATA FOR PHYSICAL SCIENCES GRADE 12  
PAPER 1 (PHYSICS)**

**GEGEWENS VIR FISIESTE WETENSKAPPE GRAAD 12  
VRAESTEL 1 (FISIKA)**

**TABLE 1: PHYSICAL CONSTANTS/TABEL 1: FISIESTE KONSTANTES**

NAME/NAAM	SYMBOL/SIMBOOL	VALUE/WAARDE
Acceleration due to gravity <i>Swaartekragversnelling</i>	g	9,8 m·s <sup>-2</sup>
Universal gravitational constant <i>Universele gravitasiekonstant</i>	G	6,67 x 10 <sup>-11</sup> N·m <sup>2</sup> ·kg <sup>-2</sup>
Radius of the Earth <i>Radius van die Aarde</i>	R <sub>E</sub>	6,38 x 10 <sup>6</sup> m
Mass of the Earth <i>Massa van die Aarde</i>	M <sub>E</sub>	5,98 x 10 <sup>24</sup> kg
Speed of light in a vacuum <i>Spoed van lig in 'n vakuum</i>	c	3,0 x 10 <sup>8</sup> m·s <sup>-1</sup>
Planck's constant <i>Planck se konstante</i>	h	6,63 x 10 <sup>-34</sup> J·s
Coulomb's constant <i>Coulomb se konstante</i>	k	9,0 x 10 <sup>9</sup> N·m <sup>2</sup> ·C <sup>-2</sup>
Charge on electron <i>Lading op elektron</i>	e	-1,6 x 10 <sup>-19</sup> C
Electron mass <i>Elektronmassa</i>	m <sub>e</sub>	9,11 x 10 <sup>-31</sup> kg

**TABLE 2: FORMULAE/TABEL 2: FORMULES****MOTION/BEWEGING**

$v_f = v_i + a \Delta t$	$\Delta x = v_i \Delta t + \frac{1}{2} a \Delta t^2$ or/of $\Delta y = v_i \Delta t + \frac{1}{2} a \Delta t^2$
$v_f^2 = v_i^2 + 2a\Delta x$ or/of $v_f^2 = v_i^2 + 2a\Delta y$	$\Delta x = \left( \frac{v_i + v_f}{2} \right) \Delta t$ or/of $\Delta y = \left( \frac{v_i + v_f}{2} \right) \Delta t$

**FORCE/KRAG**

$F_{\text{net}} = ma$	$p = mv$
$F_{\text{net}} \Delta t = \Delta p$ $\Delta p = mv_f - mv_i$	$w = mg$
$F = \frac{Gm_1 m_2}{r^2}$	$g = \frac{Gm}{r^2}$
$f_s^{\text{max}} = \mu_s N$	$f_k = \mu_k N$

**WORK, ENERGY AND POWER/ARBEID, ENERGIE EN DRYWING**

$W = F \Delta x \cos \theta$	$U = mgh$ or/of $E_p = mgh$
$K = \frac{1}{2} mv^2$ or/of $E_k = \frac{1}{2} mv^2$	$W_{\text{net}} = \Delta K$ or/of $W_{\text{net}} = \Delta E_k$ $\Delta K = K_f - K_i$ or/of $\Delta E_k = E_{kf} - E_{ki}$
$W_{\text{nc}} = \Delta K + \Delta U$ or/of $W_{\text{nc}} = \Delta E_k + \Delta E_p$	$P = \frac{W}{\Delta t}$
$P_{\text{ave}} = F v_{\text{ave}}$	

**WAVES, SOUND AND LIGHT/GOLWE, KLANK EN LIG**

$v = f \lambda$	$T = \frac{1}{f}$
$f_L = \frac{v \pm v_L}{v \pm v_s} f_s$ $f_L = \frac{v \pm v_L}{v \pm v_b} f_b$	$E = hf$ or/of $E = h \frac{c}{\lambda}$
$E = W_o + E_k$ where/waar $E = hf$ and/en $W_o = hf_o$ and/en $E_k = \frac{1}{2} mv^2$	

**ELECTROSTATICS/ELEKTROSTATIKA**

$F = \frac{kQ_1Q_2}{r^2}$	$E = \frac{kQ}{r^2}$
$E = \frac{F}{q}$	$V = \frac{W}{q}$
$n = \frac{Q}{e}$ or/of $n = \frac{Q}{q_e}$	

**ELECTRIC CIRCUITS/ELEKTRIESE STROOMBANE**

$R = \frac{V}{I}$	emf ( $\epsilon$ ) = I(R + r) emk ( $\epsilon$ ) = I(R + r)
$R_s = R_1 + R_2 + \dots$ $\frac{1}{R_p} = \frac{1}{R_1} + \frac{1}{R_2} + \dots$	$q = I \Delta t$
$W = Vq$ $W = VI\Delta t$ $W = I^2R \Delta t$ $W = \frac{V^2\Delta t}{R}$	$P = \frac{W}{\Delta t}$ $P = VI$ $P = I^2R$ $P = \frac{V^2}{R}$

**ALTERNATING CURRENT/WISSELSTROOM**

$I_{rms} = \frac{I_{max}}{\sqrt{2}}$ / $I_{wgk} = \frac{I_{maks}}{\sqrt{2}}$	$P_{average} = V_{rms} I_{rms}$ / $P_{gemiddeld} = V_{wgk} I_{wgk}$
$V_{rms} = \frac{V_{max}}{\sqrt{2}}$ / $V_{wgk} = \frac{V_{maks}}{\sqrt{2}}$	$P_{average} = I_{rms}^2 R$ / $P_{gemiddeld} = I_{wgk}^2 R$
	$P_{average} = \frac{V_{rms}^2}{R}$ / $P_{gemiddeld} = \frac{V_{wgk}^2}{R}$