



basic education

Department:
Basic Education
REPUBLIC OF SOUTH AFRICA

AGRICULTURAL TECHNOLOGY

GUIDELINES FOR PRACTICAL ASSESSMENT TASKS

GRADE 12

2019

These guidelines consist of 23 pages.

TABLE OF CONTENTS

1. INTRODUCTION		3	
2. TEACHER GUIDELINES		3	
2.1	Practical Assessment Task (PAT) for 2019	3	
2.2	How to administer the PAT	4	
2.3	Phases in the development of the PAT project	5	
2.3.1	Phase 1: Design portfolio	5	
2.3.2	Phase 2: Manufacturing process	6	
2.3.3	Phase 3: Final product	6	
2.4	Criteria and guidelines for PAT assessment	6	
2.4.1	Criteria and guidelines for assessing the design portfolio	7	
2.4.2	Criteria and guidelines for assessing the manufacturing process	7	
2.4.3	Criteria and guidelines for assessing the final product	7	
2.5	Moderation of PAT	7	
3. LEARNER GUIDELINES		8	
3.1	Introduction	8	
3.2	Illustration of the PAT	8	
3.3	List of consumable materials and tools needed	8	
3.4	Procedure to be followed for the process	9	
3.5	Safety	12	
3.6	Alternative designs	12	
4. CONCLUSION		13	
5. ASSESSMENT RUBRICS		14	
5.1	Assessment rubric for the design portfolio	ANNEXURE A	14
5.2	Assessment rubric for the manufacturing process	ANNEXURE B	16
5.3	Assessment rubric for the final product	ANNEXURE C	17
5.4	Declaration of Authenticity	ANNEXURE D	18
5.5	External/Internal moderation tool for PAT	ANNEXURE E	19
5.6	Mark schedule	ANNEXURE F	22
5.7	Agricultural Technology consolidation form	ANNEXURE G	23

1. INTRODUCTION

The 17 Curriculum and Assessment Policy Statements (CAPS) subjects which contain a practical component all include a practical assessment task (PAT)

These subjects are:

- **AGRICULTURE:** Agricultural Management Practices, Agricultural Technology
- **ARTS:** Dance Studies, Design, Dramatic Arts, Music, Visual Arts
- **SCIENCES:** Computer Applications Technology, Information Technology, Technical Sciences
- **SERVICES:** Consumer Studies, Hospitality Studies, Tourism
- **TECHNOLOGY:** Civil Technology, Electrical Technology, Mechanical Technology and Engineering Graphics and Design

A practical assessment task (PAT) is a compulsory component of the final promotion mark for all candidates offering subjects that have a practical component and counts 25% (100 marks) of the end-of-year examination mark. The PAT is implemented across the first three terms of the school year, which is broken down into different phases or a series of smaller activities that make up the PAT. The PAT allows for learners to be assessed on a regular basis during the school year and also allows for the assessment of skills that cannot be assessed in a written format, e.g. test or examination. It is therefore important for schools to ensure that all learners complete the PAT within the stipulated period to ensure that learners are resulted at the end of the school year. The planning and execution of the PAT differs from subject to subject.

2. TEACHER GUIDELINES

2.1 Practical Assessment Task (PAT) for 2019

The aim of the PAT is to teach learners to solve technological problems in the agricultural environment by making use of critical, innovative thinking skills.

The PAT comprises a design component, manufacturing component and a final product. The PAT leads the learner to be able to design and develop the product according to technological processes.

Schools will be informed of the Grade 12 project in the term 4 of Grade 11 in order to allow the teacher and learner to do planning in advance.

The following is a scenario and a complete layout of the example model that can be used as PAT for 2019.

Scenario:

A farmer needs a work bench that can be used as a work platform for various purposes on and around the farm. Design a practical work bench that can be used effectively in this situation.

The work bench must be versatile to be used in various circumstances or conditions. It must be light, simple and easy to handle, but sturdy enough to carry heavy loads. It must not topple over easily when used.

Use various technological processes to help you in the design and manufacturing of this piece of equipment, e.g. planning, investigation, research and various practical skills.

2.2 How to administer the PAT

This PAT document must be used by the teacher as a guideline on how the PAT must be done. The learner must design and plan the whole PAT individually with guidance from the teacher. The teacher will only provide the learners with the problem statement. Ideally, all the learners should have different PAT designs. The teacher must evaluate the learner's design for practicality and make suggestions before the learner submits the final design portfolio.

If the school/learners decide to do an alternative PAT, the PAT must comply with the prescribed standards set by this PAT guideline document. This must include evidence of the design portfolio, work procedure, rubrics and the evidence of the final project. The criteria and format for assessing the design portfolio; manufacturing process and final product must be the same as that of the prescribed PAT.

The project must consist of at least SEVEN of the given criteria as stated on pages 46–47 in the *Agricultural Technology Curriculum and Assessment Policy Statement (CAPS)*.

The model should have functional value and must be usable in real life, farm and workshop situations. The learners should be familiar with the assessment criteria before they start with the task. The PAT must be done under the supervision of the designated teacher.

The practical assessment task in Grade 12 is externally set, internally assessed and externally moderated. The PAT is completed under controlled conditions and is assessed by means of rubrics.

The promotion mark of Agricultural Technology consists of a PAT component of 100 marks (25%), a school-based assessment (SBA) component of 100 marks (25%) and a final examination component of 200 marks (50%). The PAT contributes 25% of the total promotion mark (400) in Grade 12. The practical assessment task is 100 marks and consists of a design portfolio (25 marks), a manufacturing process (50 marks) and the final product (25 marks).

Before a learner can commence with the manufacturing process, the design portfolio must be completed and assessed by the teacher. The reason for this is that the teacher must identify design flaws for the learner to correct.

The design portfolio and final project must be available for monitoring and moderation. The PAT must be evaluated, checked and authenticated by the teacher before it is presented as the learner's final evidence of performance.

The teacher's PAT file must contain evidence of:

- (a) The PAT task
- (b) A complete record of assessment and must always be available for monitoring and moderation purposes

The design portfolio and final project must be available for monitoring and moderation at the school during the entire school year. External moderation will be done by the respective provincial moderators and the national Department of Basic Education. No learner is allowed to take his/her project home before external moderation has been completed.

Failure by the teacher to maintain a record of the assessment of the PAT is a misconduct and will be dealt with in terms of paragraph 5(3) of the policy document, *National policy on the conduct, administration and management of the National Senior Certificate: A qualification at Level 4 on the National Qualifications Framework (NQF)*, or other appropriate measures.

The absence of marks for the practical assessment task in Grade 10–12, without a valid reason, will result in the candidate, registered for that particular subject, receiving an incomplete result. The candidate will be given three weeks' time before the commencement of the final end-of-year examination to submit the outstanding practical assessment task. Should the candidate fail to present the practical assessment task the candidate will be informed that he/she did not meet the minimum requirements for promotion and that he/she must repeat the subject the following year.

2.3 Phases in the development of the PAT project

The project should be completed over the following three phases:

2.3.1 Phase 1: Design Portfolio

Learners must identify the problem or need in their chosen project. He/She must also investigate the project, generate ideas and arrive at possible design solutions to make or produce, evaluate and communicate a solution to the problem or need. The evidence of this phase will be located in the design portfolio which will start in the last term of Grade 11 and continue to the end of January of the Grade 12 year. In this phase the learner must be encouraged to be creative and show initiative.

A Declaration of Authenticity (**ANNEXURE D**) must be completed for each learner before final moderation.

The design portfolio should include evidence of how the development of the product was approached as indicated below:

- Analysis and planning of the assignment
- Relationship between technology, society and environment
- Sketches, diagrams or calculations
- Materials used
- Tools used
- General safety rules that are applicable
- Comparisons of processes and tools to be used
- Cost calculations and material list
- Knowledge and skills needed in the manufacturing process
- Manufacturing processes that were followed
- Planning of time from the start to the final product
- Research or investigations undertaken
- Any other information that is relevant to the project

Format of the design portfolio:

Cover page:	Learner's name Grade School Examination number Year
Index:	Assignment Planning and research Design sketches Material list Tools needed and relevant safety measures Comparisons of processes and tools to be used Cost calculations Source list Steps to follow Any additional information

2.3.2 Phase 2: Manufacturing process

Learners start constructing the actual model at the beginning of February during term 1 in Grade 12 or as soon as a learner has finished with the design portfolio and it has been approved by the teacher. From here the learner commences with Phase 2. The model must be completed by the middle of term 3 in Grade 12.

The learner is expected to do the manufacturing of the model in the school's workshop, under close supervision of the teacher. Processes not performed by the learner cannot be assessed as part of the learner's work.

The model must include a number of practical skills, but it must be remembered that the model must adhere to the minimum number of skills, as prescribed by the subject CAPS document.

Continuous assessment must be undertaken by the teacher during the manufacturing process to evaluate and assess certain skills and processes with the aid of the given rubric.

2.3.3 Phase 3: Final product

Learners submit the models for assessment by the end of the term 3. The planning done in Phase 1 (design portfolio) must also be submitted for assessment of the final product. For final assessment, the model must be completed and fully functional. The final product must correspond with the planning in Phase 1.

2.4 Criteria and guidelines for PAT assessment

The PAT consists of THREE phases. Each phase must be assessed by the teacher with the aid of the attached rubrics.

- The DESIGN PORTFOLIO must be completed and marked not later than the end of term 1. As soon as a learner is finished with the design portfolio and has been assessed and approved by the teacher, he/she can commence with Phase 2. The teacher must use the rubric on **ANNEXURE A** to assess the design portfolio.
- The MANUFACTURING PROCESS is a continuous process and the various skills must continuously be assessed by the teacher when the different skills are applied. The rubric on **ANNEXURE B** must be used.
- The FINAL PRODUCT must be evaluated and assessed according to the rubric, **ANNEXURE C**.
- **ANNEXURE D** is a Declaration of Authenticity and must be completed for each learner.
- **ANNEXURE E** must be used by the teacher to ensure that the Agricultural Technology workshop and facility is up to standard for external moderation.
- **ANNEXURES F** and **G** are examples of mark sheets that can be used.

2.4.1 Criteria and guidelines for assessing the DESIGN PORTFOLIO (25 marks)

- Analysis of problem
- Interrelationship between technology, society and the environment
- Ability to generate ideas
- Providing a solution
- Sketching (dimensions, welding symbols, scale and projection symbols)
- Materials, tools and equipment
- General safety rules
- Cost calculations and material list
- Evidence of comparisons between different processes and skills
- Portfolio presentation

2.4.2 Criteria and guidelines for assessing the MANUFACTURING PROCESS (face moderation) (50 marks)

- Safe handling and maintenance of tools and equipment
- Skills related to proper use and maintenance of tools and equipment
- Knowledge of materials to solve problems
- Application of different techniques and processes
- Skills demonstrated in the application of processes

2.4.3 Criteria and guidelines for assessing the quality of the FINAL PRODUCT (25 marks)

- The product fulfils the purpose for which it was designed and shows innovation that is appropriate to the problem
- Dimensions and measurements of the final product
- Appearance: Finishing includes filing, grinding, sanding and painting
- Ensure that the product functions properly
- Time management: Check for the completeness of the product.

2.5 Moderation of the PAT

- **Internal moderation (Head of Department)**
The teacher and learner PAT portfolios must be moderated by the Head of Department or senior teacher of the subject in the school.
- **External moderation (Subject Specialist/Advisor)**
The subject specialist/advisor must do external moderation ONCE A TERM. At the end of term 1 the subject specialist must assess the design portfolio. During the course of term 2, the actual manufacturing process by the learner must be moderated. The final product and the final PAT mark must be moderated in term 3.
- **External moderation (National Panel)**
A panel of moderators appointed by the national Department of Basic Education will moderate the PAT and practical workshop. **ANNEXURE E** is the moderation tool that will be used by the national panel for moderation of schools.

3. LEARNER GUIDELINES

3.1 Introduction

The model to be constructed by the learners must include the processes taught in the theoretical work over the years from Grade 10. These processes are part of various tasks that can be undertaken on a farm. The learners use their skills and knowledge acquired in Agricultural Technology to engage in this project.

3.2 Illustration of the PAT

The picture below shows a practical work bench that can be used as a bench to weld on.

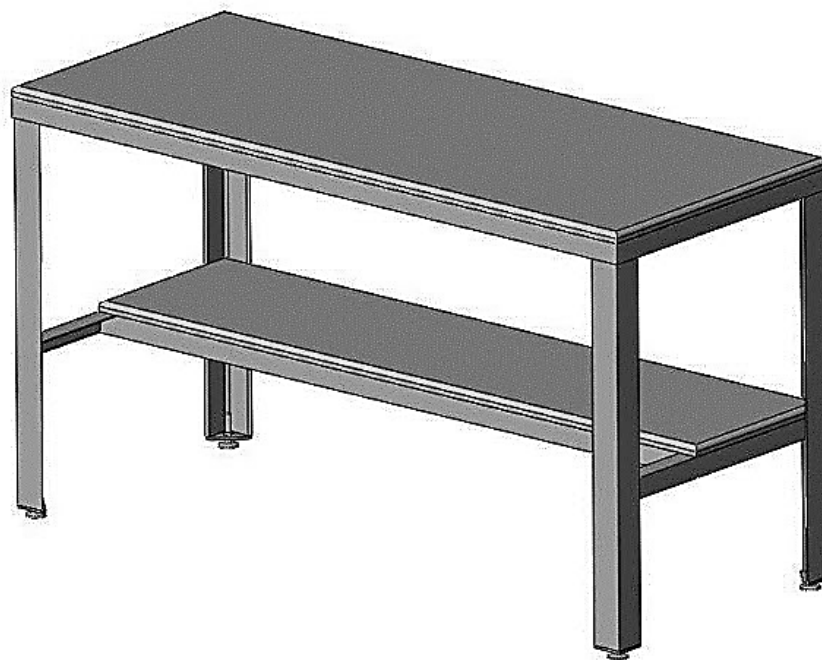



3.3 Lists of consumable materials, machines and tools that are needed to manufacture the project.

Tools needed		
Cut-off machine	Mitre square	Flat and round file
Drilling machine	Hacksaw	Personal protection clothing
Plasma cutting machine	Scriber	Broom
Welding machine	Centre punch	Paint brush
Work bench	Spanners	Hammer
Angle grinder	Pliers	Clamps
Tape measure		
Consumable materials		
Steel drill bit Ø 12 mm		Hacksaw blades
Grinding/Cutting discs/Plasma cutter accessories (nozzle; inserts; spacers)		Turpentine Pencil
Rust-Oleum high temperature spray paint		Hand cleaner
Welding rods		Undercoat paint

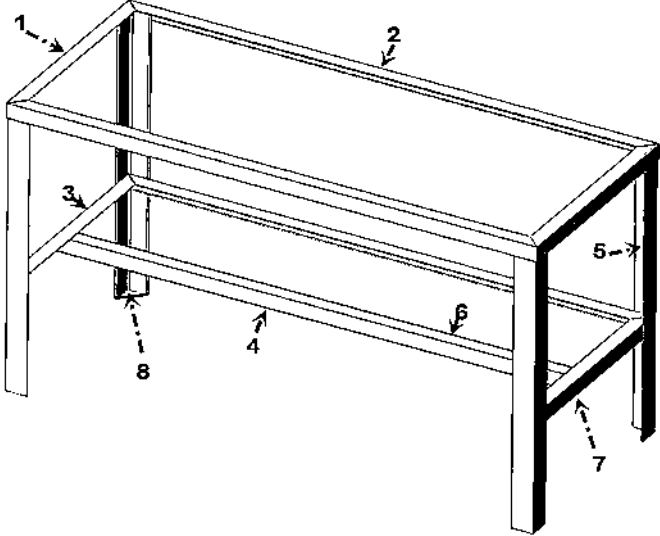
3.4 Procedure to be followed for the manufacturing process

<p>PROPOSED WORK/TIME SCHEDULE</p> <p>Approximately 2 hours per week is needed for the PAT as prescribed in the CAPS document. Approximately 18 weeks (36 hours) are available for the manufacturing process.</p>	<p>Predicted date</p>
<p>A DESIGN PORTFOLIO (25 marks)</p> <ol style="list-style-type: none"> The PAT problem/statement/task must be handed to the learners. The teacher must explain the problem/statement/task. Learners have THREE weeks to complete the design portfolio. The teacher must be actively involved and provide support to the learners during the design process. The teacher must collect, evaluate, assess and give feedback to the learner of the finished portfolio before the learners can commence with the manufacturing process. The learners must do the corrections on the design portfolio where necessary. The teacher must record the marks of the design portfolio on the SBA mark sheet. 	<p>Week 1</p> <p>Week 2</p> <p>Week 3</p>
<p>B MANUFACTURING PROCESS (50 marks) (Teacher must monitor and evaluate the manufacturing process)</p> 	

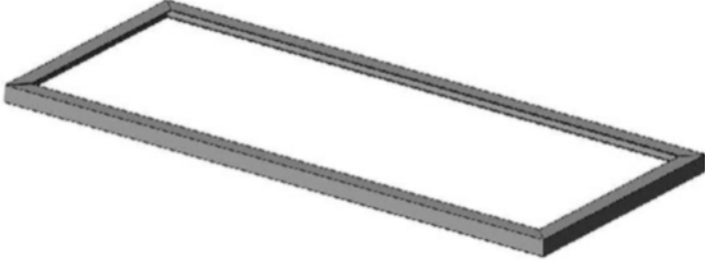
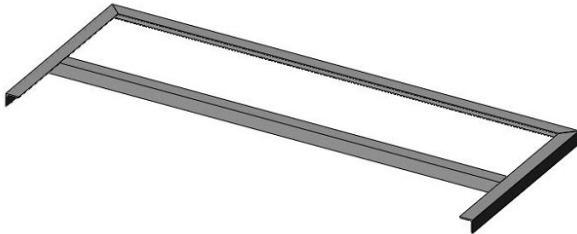
ITEM NO.	QTY.	DESCRIPTION	LENGTH	COST
1.	2	Angle iron 50 mm x 50 mm x 5 mm	750 mm	
2.	2	Angle iron 50 mm x 50 mm x 5 mm	1 800 mm	
3.	1	Angle iron 50 mm x 50 mm x 5 mm	740 mm	
4.	1	Angle iron 50 mm x 50 mm x 5 mm	1 790 mm	
5.	4	Angle iron 75 mm x 75 mm x 5 mm	950 mm	
6.	1	Angle iron 50 mm x 50 mm x 5 mm	1 790 mm	
7.	1	Angle iron 50 mm x 50 mm x 5 mm	740 mm	
8.	4	Triangular foot plate mounting	65 mm x 65 mm	

<p>Step 1: Cut items 1 and 2, as shown in drawing #2.</p>	<p>Week 4–7</p>
<p>Step 2: Weld items 1 and 2 in a rectangular frame, as shown below. This will make the work bench top frame. Make sure the frame is flat with squared 90 degree corners.</p> 	<p>Week 8–10</p>
<p>Step 3: Cut FOUR item # 5s. These will become the legs of the bench. Make sure they are all the same length. Flip the bench top frame upside down and weld the legs perpendicular to the bench top frame. Ensure that they are square.</p>	<p>Week 10–15</p>
<p>Step 4: Weld items 3, 4, 6 and 7 together as shown below, referencing the work bench drawing for dimensions. This creates the shelf frame that will be located under the bench top. Make sure the frame is flat with squared 90 degree corners.</p> 	<p>Week 16–19</p>
<p>Step 5: Position the shelf frame as indicated on the drawing and tack weld in place. Make sure the shelf frame is positioned the same distance from the bottom of each work bench leg before final welding. Weld as indicated on drawing.</p> 	<p>Week 20–24</p>

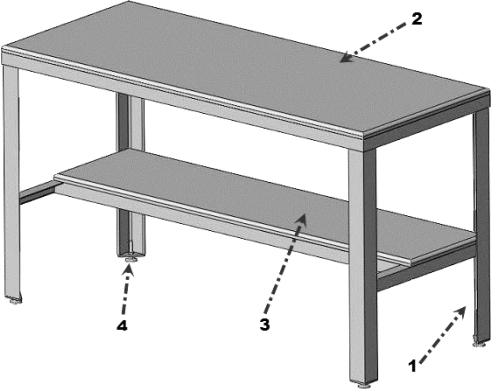
<p>Step 6: Weld FOUR item 8 (foot plate) to the bottom of the bench legs, as shown below.</p>	Week 25–29
<p>Step 7: Clean and smooth all surfaces.</p>	Week 30
<p>Step 8: Prime and paint the welded frame for rust prevention. Allow the paint to dry completely.</p> 	Week 30

ITEM NO.	QTY.	DESCRIPTION	LENGTH	COST
1.	1	Work bench	1 800 mm x 750 mm x 950 mm	
2.	1	Work bench top (Steel plate)	1 800 mm x 750 mm x 10 mm	
3.	1	Work bench shelf (Steel plate)	1 790 mm x 540 mm x 2 mm	
4.	1	Levelling foot	10 mm bolt and nut	

<p>Step 9: Clamp the steel plate bench top (item No. 2) and shelf plate (item No. 3) to the welded frame, taking care that the edges line up. Weld the plates to the respective frames.</p>	Week 31
<p>Step 10: Attach the levelling feet (item No. 4) to the bottom of the bench legs.</p>	Week 32
Completed work bench	
<p>C FINAL PRODUCT (25 marks)</p> <ul style="list-style-type: none"> Teacher must evaluate the final product and finalise the PAT marks for the year. Marks must be recorded on the SBA mark sheets. 	Week 33

3.5 Safety

- Working safely and using the work bench in a responsible manner will reduce your chances of an accident or injury.
- Be sure to wear the appropriate safety gear and clothing for welding and metalworking. Clothing should be made of fire-retardant cotton or wool, never synthetics which can melt.
- Always wear a helmet when welding and a full face shield when grinding.
- Also wear leather welding gloves to protect against burns.
- You should always work in a well-ventilated area.

3.6 Alternative designs



4. CONCLUSION

On completion of the practical assessment task learners should be able to demonstrate their understanding of the industry, enhance their knowledge, skills, values and reasoning abilities as well as establish connections to life outside the classroom and address real-world challenges. The PAT furthermore develops learners' life skills and provides opportunities for learners to engage in their own learning.

5. ASSESSMENT RUBRICS**ANNEXURE A**

Name of Candidate: _____ School: _____ Grade: _____ Date: _____

DESIGN PORTFOLIO	MANUFACTURING PROCESS	QUALITY OF PRODUCT	TOTAL	SIGNATURE OF TEACHER	SIGNATURE OF EXTERNAL MODERATOR
/25	/50	/25	/100		

5.1 ASSESSMENT RUBRIC FOR THE DESIGN PORTFOLIO								
CRITERIA	0	1	2	3	4	5	POSSIBLE MARK	MARK OBTAINED
Planning Skills: Analysis and diagnosis	No attempt was made and no evidence to be assessed is found.	Shows a limited attempt to identify and collect information to analyse the given problem or need.	Shows an attempt to identify and collect relevant information to analyse the given problem or need.	Identifies the given problem correctly and collects relevant information to analyse the problem or need.	Analyses the given problem correctly and shows evidence of the use of a wide range of information to understand the problem or need.	Identifies the given problem correctly and uses a variety of investigated strategies to obtain relevant information that assisted in developing and design of innovative ideas.	5	
Interrelationship between technology, society & environment	No attempt was made and no evidence to be assessed is found.	Makes no attempt to consider the interrelationship.	Awareness of the interrelationship was demonstrated.	Awareness and knowledge of interrelationship was demonstrated.	Application and knowledge of interrelationship aspects.	Application and knowledge of interrelationship aspects and the implementing of preventative measures.	5	
Generate ideas	No attempt was made and no evidence to be assessed is found.	Mentions some ideas.	Shows some awareness of alternative ideas	Offers some alternative ideas with a limited reasoning of choices.	Uses original and creative ideas and chooses the most suitable option.	Generates an excellent variety of alternative and innovative ideas. The preferred option is well justified with clear Links to the design.	5	
Solution	No attempt was made and no evidence to be assessed is found.	Attempts to come up with limited design sketches and some specifications. Constraints relating to the given problem.	Attempts to come up with design sketches, specifications and constraints relating to the given problem.	Provides design sketches and a variety of specifications and constraints relating to the given problem.	Provides excellent design sketches and a list of relevant specifications and constraints to the given problem.	Provides excellent innovative design sketches that is extremely well formulated and defines the need according to the given problem.	5	

CRITERIA	0	1	2	3	4	5	POSSIBLE MARK	MARK OBTAINED
Sketching	No attempt was made and no evidence to be assessed is found.	Provides irrelevant sketches that demonstrate limited drawing skills.	Provides some relevant sketches with incorrect lines and/or wrong symbols.	Provides relevant sketches with correct lines and symbols.	Provides sketches with correct lines and symbols and related to the given problem.	Provides excellent sketches according to the given problem considering possible solutions.	5	
Material, tools & equipment list	No attempt was made and no evidence to be assessed is found.	Attempts to list some material, tools & equipment.	Provides a list of material, tools and equipment incorrect or insufficient.	Provides a list of relevant material, tools and equipment.	Provides a list with a variety of relevant material, tools and equipment needed.	Provides a list of the most relevant material, tools and equipment needed in a creative format.	5	
General Safety	No attempt was made and no evidence to be assessed is found.	Attempts to consider Safety Regulations.	Shows some awareness of Safety Regulations.	Shows awareness, knowledge and application of Safety Regulations.	Shows awareness, knowledge and application of Safety Regulations regarding a variety of conditions.	Shows awareness, knowledge and application of Safety Regulations regarding all conditions and considers preventative measures.	5	
Cost calculations and material list	No attempt was made and no evidence to be assessed is found.	Provide a material list with no calculations.	Attempts to do cost calculations by using incorrect units, data and material list.	Provides cost calculations using correct units and data collected without consideration of constraints.	Provides cost calculations using correct units and data collected and considers constraints.	Provides cost calculations using correct units and data collected and considers relevant constraints.	5	
Comparisons	No attempt was made and no evidence to be assessed is found.	No comparisons	Poor comparison of one process	Comparison of different processes, skills and materials	A thorough comparison of different processes, skills and materials	A thorough comparison of different processes, skills and materials and come to a conclusion.	5	
Portfolio presentation	No attempt was made and no evidence to be assessed is found.	The portfolio is incomplete and poorly ordered and prepared.	The portfolio is completed but poorly ordered and prepared.	The portfolio is completed and adequately ordered and prepared.	The portfolio is completed and well presented.	The completed portfolio presentation shows a high level of innovation and creativity.	5	
TOTAL MARK							50÷2 =25	

5.2 ASSESSMENT RUBRIC FOR THE MANUFACTURING PROCESSES							ANNEXURE B	
CRITERIA	0	1	2	3	4	5	POSSIBLE MARK	MARK OBTAINED
Safe handling of tools/ equipment (face moderation)	No attempt was made and no evidence to be assessed is found.	Demonstrates awareness of safety measures.	Demonstrates awareness and knowledge of some safety measures.	Demonstrates adequate knowledge and awareness of applicable safety measures.	Demonstrates sufficient knowledge and awareness of all applicable safety measures.	Demonstrates sufficient knowledge and awareness of all applicable safety measures and apply preventative measures.	5	
Skills relating to handling of tools and equipment (face moderation)	No attempt was made and no evidence to be assessed is found.	Demonstrates limited knowledge and skills of equipment related to tools used.	Demonstrates some knowledge and skills related to tools and equipment used and housekeeping.	Demonstrates adequate knowledge and skills related to tools and equipment used and evidence of housekeeping.	Demonstrate adequate knowledge and skills related to tools and equipment used and good housekeeping.	Demonstrate sufficient knowledge and skills related to maintenance and use of tools and equipment and excellent housekeeping.	5	
Knowledge of materials	No attempt was made and no evidence to be assessed is found.	Shows limited background knowledge on materials used.	Shows some knowledge of materials and their properties.	Shows adequate knowledge of materials and their properties and concepts.	Shows adequate knowledge of materials and their properties, concepts and principles.	Shows sufficient knowledge of materials and their properties, concepts and principles to solve problems.	5	
Process techniques	No attempt was made and no evidence to be assessed is found.	Demonstrate some knowledge of inappropriate techniques used.	Demonstrates limited knowledge of techniques used.	Demonstrates adequate knowledge of correctly selected techniques.	Demonstrates adequate knowledge on how to select and apply the relevant techniques correctly.	Demonstrate sufficient knowledge of correctly selected and applied techniques considering possible constraints.	5	
Skills used in processes (face moderation)	No attempt was made and no evidence to be assessed is found.	Demonstrates limited knowledge of skills needed.	Demonstrate some knowledge of skills needed.	Demonstrate adequate knowledge of skills needed.	Demonstrate adequate knowledge of skills needed and considering some constraints.	Demonstrate sufficient knowledge of skills needed and considering relevant constraints.	5	
TOTAL MARK							25 x 2=50	

5.3 ASSESSMENT RUBRIC FOR THE QUALITY OF THE FINISHED PRODUCT							ANNEXURE C	
CRITERIA	0	1	2	3	4	5	POSSIBLE MARK	MARK OBTAINED
Address the problem/need	No attempt was made and no evidence to be assessed is found.	The product is incomplete. The completed product lacks details and makes interpretation difficult.	The product is complete but do not address the problem or need at all.	The product is complete and addresses the problem or need partly.	The product fulfils the purpose for which it was designed and shows no real evidence of innovation in the solution to the identified problem or need.	The product fulfils the purpose for which it was designed and shows innovation that is appropriate to the identified problem or need.	5	
Dimensions and measurements of the final product	No attempt was made and no evidence to be assessed is found.	Dimensions differ completely from original design. Shows no effort in making correct measurements.	Dimensions differ from original design but show some effort in making correct measurements.	Some dimensions differ from original drawing design. More accuracy and effort is shown in making correct measurements.	Dimensions differ slightly from original design. Shows much more accuracy and effort in making correct measurements.	Measurements and dimensions correlate completely with original design.	5	
Appearance: Finishing off. Filing, grinding, sanding and painting	No attempt was made and no evidence to be assessed is found.	No finishing off. No filing, painting or sanding. Shows little effort in making the appearance acceptable.	Product's appearance not acceptable due to some of the finishing methods that were not followed.	Product's appearance acceptable due to some of the finishing methods that were used.	Product's appearance more acceptable due to finishing off that was done but no painting.	Product's appearance is very acceptable and shows a high level of innovation and creativity.	5	
Functionality of the final product. Does the product function properly?	No attempt was made and no evidence to be assessed is found.	The product is incomplete and does not function at all.	The product is complete but it is not functional at all and shows no new improvements.	The product is complete, and functions but shows no new improvements and little innovation.	The product is complete, functions well and shows some new improvements and innovation.	The product is complete, functions very well and shows many new improvements and a very high level of innovation.	5	
Time management	No attempt was made and no evidence to be assessed is found.	Very little evidence of time management.	Demonstrates some sense of time management but planning not realistic.	Evidence of realistic time management on planning but does not keep to the plan.	Manages time well according to the initial plan.	Manages time exceptionally well by considering alternatives according to the initial plan.	5	
TOTAL MARK							25	

5.4 **DECLARATION OF AUTHENTICITY****ANNEXURE D****DECLARATION OF AUTHENTICITY**

The **DESIGN PORTFOLIO** has been presented in one off the following ways: Sourcebook, Workbook or File. It is part of the Subject Portfolio. The **DESIGN PORTFOLIO** must be completed prior to the manufacturing process.

The following has been included in the **DESIGN PORTFOLIO**:

- Analysis of the problem
- Interrelationship between technology, society and the environment
- Ability to generate ideas
- Providing a solution
- Sketching (dimensions, welding symbols, scale, and projection symbols)
- Materials, tools & equipment
- General safety rules
- Cost calculations and material list
- Evidence of comparisons between different processes and skills
- Portfolio presentation

The complete PAT was done under the supervision of the designated teacher and without the help of anybody else. This is to certify that all work submitted is the original and own work of the learner. Processes not performed by the learner have not been assessed as part of the learner's work.

Learner		
School		
District		
	Signature	Date
Learner		
Teacher		
Principal		

School Stamp

5.5 EXTERNAL/INTERNAL MODERATION TOOL FOR PAT

ANNEXURE E

AGRICULTURAL TECHNOLOGY

SCHOOL: _____ EMIS No.: _____

TEACHER: _____ GRADE: _____

SUBJECT SPECIALIST: _____ DATE: _____

NUMBER OF LEARNERS IN GRADE: _____

NUMBER OF LEARNERS TAKING THE SUBJECT IN GRADES 10–12: _____

1	CONDITION OF THE WORKSHOP	GOOD <input checked="" type="checkbox"/>	ACCEPTABLE <input checked="" type="checkbox"/>	POOR <input checked="" type="checkbox"/>	COMMENTS
	Windows				
	Ceiling				
	Floor				
	Oil-resistant floor paint				
	Walls				
	Lights				
	Sufficient electric wall sockets				
	Electric wall sockets in working condition				
	Ventilation				
	Burglar-proofing				
2	TEACHER				YES <input checked="" type="checkbox"/> NO <input checked="" type="checkbox"/>
	Preparation File:				
	☞ PAT Guideline Document				
	☞ Mark sheet				
	☞ Learner rubrics				
	☞ Reference Material (additional information and resources given to learners by the teacher)				
	Safety:				
	☞ Safety screens/devices				
	☞ Acetylene/gas cylinders safe				
	☞ Welding areas well screened off				
	☞ Area around dangerous machines demarcated with yellow lines on the floor				
	☞ Serviced fire extinguisher				
	☞ First-aid kit				
	☞ Safety posters				
	☞ Safety signs				
	☞ Applicable OHS acts implemented in workshop				
	☞ Number of learners in workshop per session not more than 15 as stipulated by the OHS Act				
	Tools & Equipment:				
	☞ Fully equipped workshop				
	☞ Basic tools and equipment				
	☞ Damaged and broken equipment				
	☞ Shadow boards are against the walls or mobile units				

	Workshop atmosphere:	
	👉 Posters	
	👉 Exhibits	
	👉 Safe layout	
	👉 Workshop purpose is build	
	Cleanliness of storeroom:	
	👉 Storeroom is well organised	
	👉 Storeroom is clean	
	Cleanliness of workshop:	
	👉 Workshop is clean	
3	LEARNERS' PAT PROJECT FILES	YES <input checked="" type="checkbox"/> NO <input type="checkbox"/>
	Learners follow the prescribed PAT.	
	If not, is the PAT project of same standard or higher than the prescribed PAT?	
	All learners have PAT portfolio files.	
	All learners have a completed learner summary record sheet.	
	All learners complete the Declaration of Authenticity (page 18)	
	All learners have copies of design project pages (pages 8 to 13) in their PAT files.	
	Learners completes the following phases of the PAT sufficiently:	
	👉 Design	
	👉 Manufacturing	
	Evidence exists that all tasks have been assessed by the teacher.	
	All the rubrics have been completed and totals carried over to the mark sheet correctly.	
	The assessment conducted by the teacher is fair and reliable.	
	The mark allocation and level of achievement are in line with the rest of the province.	
	Adjustment of the average is needed.	
4	OVERALL QUALITY OF THE PROJECT	YES <input checked="" type="checkbox"/> NO <input type="checkbox"/>
	All learners completed the project.	
	All learners' work has been internally moderated.	
	Final projects match the designs in the portfolio.	
	Marks allocated by the teachers using the rubrics match the available evidence in the learner's file.	
5	INTERNAL/EXTERNAL MODERATION	YES <input checked="" type="checkbox"/> NO <input type="checkbox"/>
	There is evidence of internal moderation by the HOD.	
	There is evidence of internal moderation by the subject specialist.	
6	INTERNAL/EXTERNAL MONITORING	YES <input checked="" type="checkbox"/> NO <input type="checkbox"/>
	There is evidence of internal monitoring by the HOD.	
	There is evidence of internal monitoring by the deputy principal.	
	There is evidence of internal monitoring by the subject specialist.	
7	Additional information. Add typed lists of the following information:	
	Add list of equipment needed in the Agricultural Technology workshop.	
	Add list of equipment in excess in the Agricultural Technology workshop.	
	Add list of equipment that is broken beyond repair and that must be 'written off' in the Agricultural Technology workshop.	

5.7 Consolidation form

ANNEXURE G

AGRICULTURAL TECHNOLOGY

SCHOOL: _____ CENTRE NUMBER: _____ EMIS NUMBER: _____

CIRCUIT: _____ DISTRICT: _____ YEAR: _____

	CANDIDATES	CANDIDATE EXAM NUMBER	Design portfolio	Manufacturing of product.	Quality of the final product	TOTAL	Moderated mark
			25	50	25	100	100
1.							
2.							
		Total:					
		Average					

TEACHER _____ SIGNATURE OF TEACHER _____ DATE : _____

PRINCIPAL _____ SIGNATURE OF PRINCIPAL _____ DATE : _____

MODERATOR _____ SIGNATURE OF MODERATOR _____ DATE : _____